

Norval



Revision D

Revision D - Edition 12/2023

TRANSLATION OF ORIGINAL INSTRUCTIONS

**USE, MAINTENANCE AND
WARNING INSTRUCTIONS**

1 - INTRODUCTION

FOREWORD

All rights reserved. No part of this publication may be reproduced, distributed, translated into other languages or transmitted by any electronic or mechanical media, including photocopies, recording or any other storage and retrieval system, for any other purposes that are not exclusively the personal use of the buyer, without the express written permission of the Manufacturer.

The manufacturer is in no way responsible for the consequences of operations carried out in a manner not in accordance with the manual.

GENERAL CONSIDERATIONS

All operating, maintenance instructions and recommendations described in this manual must be observed. In order to obtain the best performance and to keep the equipment in efficient condition, the manufacturer recommends that maintenance operations be carried out regularly.

It is of particular importance that the personnel responsible for the equipment be trained in its use, maintenance and application of the safety instructions and procedures indicated in this manual.

Revision: D

1.1 - REVISION HISTORY

Revision index	Date	Revision contents
A	03/2022	First issue
B	02/2023	Chapter 5, sec. 5.2: updated pipe diameters Chapter 6, sec. 6.5.2: updated velocity limits for pressurised fluid
C	07/2023	Chapter 13, sec. 13.1: updated calibration tables for regulator
D	12/2023	Chapter 6: updated Fig. 6.16 Chapter 7: updated Tab. 7.47 Chapter 9: updated tightening torque for nut (67) for Norval 6", updated procedures 9.4.4.2, 9.4.6.1 and 9.4.7.2 Chapter 9, paras. 9.4.4.12 and 9.4.4.13: "Belleville washer (98)" changed to "washer disc (98)"

Tab. 1.1.

<

INDEX

1 - INTRODUCTION	3
1.1 - REVISION HISTORY.....	5
2 - GENERAL INFORMATION	11
2.1 - MANUFACTURER IDENTIFICATION	11
2.2 - IDENTIFICATION OF THE PRODUCT	11
2.3 - REGULATORY FRAMEWORK.....	11
2.4 - WARRANTY	11
2.5 - SYMBOLS USED IN THE MANUAL.....	12
2.6 - ADDRESSEES, SUPPLY AND STORAGE OF THE MANUAL.....	13
2.7 - LANGUAGE	13
2.8 - NAMEPLATES APPLIED	14
2.8.1 - GLOSSARY FOR NAMEPLATES	15
2.9 - GLOSSARY OF UNITS OF MEASUREMENT	16
2.10 - QUALIFIED PROFESSIONAL FIGURES.....	17
3 - SAFETY	19
3.1 - GENERAL SAFETY INSTRUCTIONS	19
3.2 - PERSONAL PROTECTIVE EQUIPMENT.....	20
3.3 - RESIDUAL RISKS	21
3.3.1 - TABLE SHOWING RESIDUAL RISKS DUE TO PRESSURE	22
3.3.2 - TABLE OF RESIDUAL RISKS FOR POTENTIALLY EXPLOSIVE ATMOSPHERES	24
3.4 - OBLIGATIONS AND PROHIBITIONS	26
3.5 - SAFETY PICTOGRAMS	27
3.6 - NOISE LEVEL	27

4 - DESCRIPTION AND OPERATION 29

4.1 - GENERAL DESCRIPTION	29
4.1.1 - REGULATOR REACTION MODES.....	30
4.2 - OPERATION.....	30
4.2.1 - ANTI-PUMPING VALVES (VAP).....	32
4.3 - INTENDED USE	33
4.3.1 - ENVISAGED USE	33
4.3.2 - REASONABLY FORESEEABLE MISUSE	33
4.3.3 - TYPES OF FLUIDS	33
4.4 - TECHNICAL FEATURES/PERFORMANCE	34
4.5 - POSSIBLE CONFIGURATIONS	35
4.5.1 - CONTROL HEADS	35
4.5.2 - ACCESSORIES	35
4.5.3 - REGULATOR WITH MONITOR FUNCTION WITH ER DEVICE	36
4.5.3.1 - REGULATOR WITH IN LINE MONITOR FUNCTION	37
4.5.4 - SLAM-SHUT VALVE	40
4.5.4.1 - INCORPORATED SN SLAM-SHUT VALVE.....	40

5 - TRANSPORT AND HANDLING 43

5.1 - SPECIFIC WARNINGS FOR TRANSPORT AND HANDLING	43
5.1.1 - PACKAGING AND FASTENERS USED FOR TRANSPORT	44
5.2 - PHYSICAL CHARACTERISTICS OF THE EQUIPMENT	46
5.2.1 - NORVAL.....	46
5.2.2 - NORVAL + ER.....	48
5.2.3 - NORVAL + SN.....	50
5.2.4 - NORVAL + ER + SN.....	52
5.3 - EQUIPMENT ANCHORING AND LIFTING METHOD.....	54
5.3.1 - FORKLIFT HANDLING METHOD.....	55
5.3.2 - CRANE HANDLING METHOD.....	57
5.4 - PACKAGING REMOVAL.....	58
5.4.1 - PACKAGING DISPOSAL	58
5.5 - STORAGE AND ENVIRONMENTAL CONDITIONS	59
5.5.1 - PRE-INSTALLATION WARNINGS AFTER PROLONGED STORAGE	59

6 - INSTALLATION 61

6.1 - INSTALLATION PRE-REQUISITES.....	61
6.1.1 - ALLOWED ENVIRONMENTAL CONDITIONS.....	61
6.1.2 - CHECKS BEFORE INSTALLATION.....	62
6.2 - SPECIFIC SAFETY INSTRUCTIONS FOR THE INSTALLATION STEP	63
6.3 - GENERAL INFORMATION ON CONNECTIONS	64
6.4 - REGULATOR INSTALLATION POSITIONS.....	65
6.5 - INSTALLATION PROCEDURES	66
6.5.1 - EQUIPMENT INSTALLATION PROCEDURE	66
6.5.2 - CONNECTION OF THE SENSING LINES TO THE DOWNSTREAM PIPING.....	66
6.6 - POST-INSTALLATION AND PRE-COMMISSIONING CHECKS	68

7 - COMMISSIONING/MAINTENANCE EQUIPMENT..... 69

7.1 - LIST OF EQUIPMENT.....	69
7.2 - EQUIPMENT NEEDED FOR THE DIFFERENT CONFIGURATIONS.....	71

8 - COMMISSIONING 73

8.1 - GENERAL WARNINGS	73
8.1.1 - SAFETY REQUIREMENTS FOR COMMISSIONING	73
8.2 - PRELIMINARY PROCEDURES FOR COMMISSIONING	74
8.3 - CHECKING THE OUTER SEAL	75
8.4 - CALIBRATION OF EQUIPMENT AND OF ACCESSORIES PRESENT	75
8.5 - COMMISSIONING THE REGULATOR	76
8.6 - COMMISSIONING PROCEDURE OF REGULATION LINE: NORVAL REGULATOR + NORVAL REGULATOR WITH IN LINE MONITOR FUNCTION	78
8.6.1 - PRESSURISING WITH EXTERNAL SOURCE.....	82
8.7 - COMMISSIONING PROCEDURE OF NORVAL REGULATOR WITH SN SLAM-SHUT VALVE.....	84
8.7.1 - INTERNAL TIGHTNESS CHECK OF SN SLAM-SHUT VALVE.....	84
8.7.2 - COMMISSIONING OF NORVAL REGULATOR WITH SN SLAM-SHUT VALVE	85
8.7.3 - CALIBRATION PROCEDURE FOR PRESSURE SWITCHES MOD. SN-91, SN-92 FOR INCORPORATED SN SLAM-SHUT VALVE	88
8.8 - COMMISSIONING PROCEDURE OF REGULATION LINE: NORVAL REGULATOR + NORVAL REGULATOR WITH IN LINE MONITOR + SN SLAM-SHUT VALVE FUNCTION	92
8.9 - DEVICE CALIBRATION.....	96
8.9.1 - CALIBRATION OF PRESSURE SWITCHES MOD. SN-91, SN-92.....	96

9 - MAINTENANCE AND FUNCTIONAL CHECKS..... 97

9.1 - GENERAL WARNINGS	97
9.2 - PERIODICALLY CHECKING AND INSPECTING THE EQUIPMENT FOR PROPER OPERATION.....	99
9.3 - ROUTINE MAINTENANCE	100
9.3.1 - GENERAL SAFETY WARNINGS.....	100
9.3.2 - REPLACEMENT FREQUENCY FOR COMPONENTS SUBJECT TO WEAR	101
9.4 - ROUTINE MAINTENANCE PROCEDURES.....	103
9.4.1 - TIGHTENING TORQUES NORVAL	104
9.4.2 - REPLACING ELEMENTS SUBJECT TO WEAR AND ABRASION.....	123
9.4.3 - ANTI-PUMPING VALVE MAINTENANCE.....	124
9.4.4 - NORVAL REGULATOR.....	126
9.4.5 - MAINTENANCE OF NORVAL REGULATOR WITH MONITOR FUNCTION WITH ER DEVICE	280
9.4.6 - MAINTENANCE OF NORVAL REGULATOR WITH SN SLAM-SHUT VALVE	294
9.4.7 - MAINTENANCE OF PRESSURE SWITCH MOD. SN	306
9.4.8 - PROCEDURE FOR RECOMMISSIONING AFTER MAINTENANCE	313

10 - TROUBLESHOOTING..... 315

10.1 -GENERAL WARNINGS	315
10.2 -OPERATOR QUALIFICATION SPECIFICATION.....	316
10.3 -TROUBLESHOOTING PROCEDURES	316
10.4 -TROUBLESHOOTING TABLES	317
10.4.1 -NORVAL REGULATOR TROUBLESHOOTING.....	317
10.4.2 -SN SLAM-SHUT VALVE TROUBLESHOOTING	320

11 - UNINSTALLATION AND DISPOSAL 321

11.1 -GENERAL SAFETY WARNINGS.....	321
11.2 -QUALIFICATION OF THE OPERATORS IN CHARGE.....	321
11.3 -UNINSTALLATION.....	321
11.4 -INFORMATION REQUIRED IN CASE OF RE-INSTALLATION.....	321
11.5 -DISPOSAL INFORMATION.....	322

12 - RECOMMENDED SPARE PARTS 323

12.1 -GENERAL WARNINGS	323
12.2 -HOW TO REQUEST SPARE PARTS.....	323

13 - CALIBRATION TABLES 325

13.2 -CALIBRATION TABLES FOR PRESSURE SWITCHES MDE. SN-91, SN-92	332
--	-----

2 - GENERAL INFORMATION

2.1 - MANUFACTURER IDENTIFICATION

Manufacturer	PIETRO FIORENTINI S.P.A.
Address	Via Enrico Fermi, 8/10 36057 Arcugnano (VI) - ITALY Tel. +39 0444 968511 Fax +39 0444 960468 www.fiorentini.com sales@fiorentini.com

Tab. 2.2.

2.2 - IDENTIFICATION OF THE PRODUCT

Equipment	MEDIUM PRESSURE REGULATOR
Model	NORVAL

Tab. 2.3.

2.3 - REGULATORY FRAMEWORK

PIETRO FIORENTINI S.P.A., with registered offices in Arcugnano (Italy) - Via E. Fermi, 8/10, declares under its sole responsibility that the equipment of the NORVAL series described in this manual is designed, manufactured, tested and checked in compliance with the requirements of EN 334 standard on gas pressure regulators.

The equipment complies with the requirements of Directive 2014/68/EU ("Pressure Equipment Directive" PED). The assessment procedure adopted is in accordance with module H1 as per Annex III of the Directive.

NOTICE!

The declaration of conformity in its original version is delivered together with the equipment and this operating and warning manual.

2.4 - WARRANTY

PIETRO FIORENTINI S.P.A. guarantees that the equipment was manufactured using the best materials, with high quality workmanship, and complies with the quality requirements, specifications and performance set out in the order.



The warranty shall be considered null and void and PIETRO FIORENTINI S.P.A. shall not be liable for any damage and/or malfunctions:

- due to any acts or omissions of the purchaser or end-user, or any of their carriers, employees, agents, or any third party or entity;
- in the event that the purchaser, or a third party, makes changes to the equipment supplied by PIETRO FIORENTINI S.P.A. without the prior written approval of the latter;
- in the event of failure by the purchaser to comply with the instructions contained in this manual, as provided by PIETRO FIORENTINI S.P.A.

NOTICE!

The warranty conditions are specified in the commercial contract.

2.5 - SYMBOLS USED IN THE MANUAL

Symbol	Definition
	Symbol used to identify important warnings for the safety of the operator and/or equipment.
	Symbol used to identify information of particular importance in the manual. The information may also concern the safety of the personnel involved in using the equipment.
	Obligation to consult the instruction manual/booklet. Refers to a requirement for personnel to refer to (and understand) the operating and warning instructions of the machine before working with or on it.

Tab. 2.4.

HAZARD!

Alerts to a hazard with a high level of risk, an imminent hazardous situation which, if not prevented, will result in death or severe damage.

WARNING!

Alerts to a hazard with a medium level of risk, a potentially hazardous situation which, if not prevented, may result in death or severe damage.

ATTENTION!

Alerts to a hazard with a low level of risk, a potentially hazardous situation which, if not prevented, could result in minor or moderate damage.

NOTICE!

Alerts to specific warnings, directions or notes of particular concern, that are not related to physical injury, as well as practices for which physical injury is not likely to occur.

2.6 - ADDRESSEES, SUPPLY AND STORAGE OF THE MANUAL

The manual is intended for the qualified technician responsible for operating and managing the equipment throughout its service life.

It contains the necessary information for the correct use of the equipment in order to maintain its functional and qualitative characteristics over time. All information and warnings for correct use in full safety are also provided.

The manual, as well as the declaration of conformity and/or test certificate, is an integral part of the equipment and must always accompany it whenever it is moved or resold. It is up to the user to keep this documentation intact for reference throughout the lifespan of the equipment.

WARNING!

Removing, rewriting or modifying the pages of the manual and their contents is not allowed.

Keep the manual near the equipment, in an accessible place known by all qualified technicians involved in using and running it.

PIETRO FIORENTINI S.p.A. shall not be held liable for any damage to people, animals and property caused by failure to adhere to the warnings and operating procedures described in this manual.

The original manual has been drawn up in Italian.

Any translations into additional languages are made from the original instructions.

2.7 - LANGUAGE

The original manual has been drawn up in Italian.

Any translations into additional languages must be made from the original manual.

HAZARD!

The Manufacturer is not responsible for any incomplete translations. If any inconsistency is found, please refer to the text of the original manual.

If inconsistencies are found or the text does not make sense:

- stop any actions;
- immediately contact the specific offices of **PIETRO FIORENTINI S.p.A.**

WARNING!

PIETRO FIORENTINI S.p.A. shall be held liable for the information provided in the original manual only.

2.8 - NAMEPLATES APPLIED







**Removing nameplates and/or replacing them with other plates is strictly prohibited.
Should the plates be unintentionally damaged or removed, the customer must notify
PIETRO FIORENTINI S.p.A.**

The equipment and its accessories are provided with nameplates (from Id.1 to Id.4).

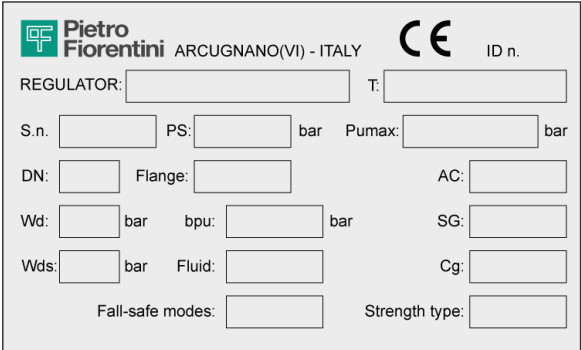
The plates specify identification details of the equipment and its accessories to be mentioned in case of need to PIETRO FIORENTINI S.p.A.

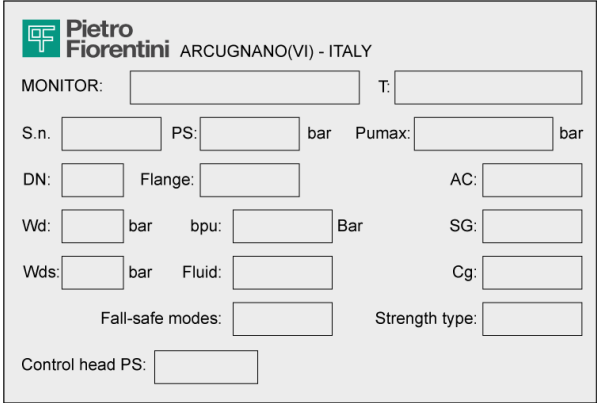
Table 2.5 shows the identification plates applied:

Id.	Type	Image
1	NAMEPLATE REGULATOR (EC version)	
2	NAMEPLATE SILENCER	
3	NAMEPLATE MONITOR	
4	NAMEPLATE SLAM-SHUT VALVE	

Tab. 2.5.

2.8.1 - GLOSSARY FOR NAMEPLATES

The terms and abbreviations used on the nameplates are described below:

Term	Description
AC	Accuracy class.
AG max	Slam-shut valve accuracy class due to pressure increase. "OPSO" (Over pressure shut off).
AG min	Slam-shut valve accuracy class due to pressure decrease. "UPSO"(Under pressure shut off).
bpu	Range of inlet pressure for which the regulator ensures a given accuracy class.
CE	Mark certifying compliance with applicable European directives.
Cg	Flow rate coefficient.
Class	Alphanumeric designation used for reference purposes related to a combination of mechanical and dimensional characteristics for flanges, in accordance with the relevant parts of EN 1759 series, which includes the word Class followed by a dimensionless whole number.
DN	Nominal size of connections.
Fail safe mode	Regulator reaction mode (Fail open or Fail close).
Flange	Type of flanged connections or type of connection thread.
Fluid	Type of fluid compatible with the equipment.
ID no.	Number of the Notified Body participating in the conformity assessment of the equipment.
Pilot	Pilot family.
PS	Maximum permissible pressure for which the equipment was designed.
Pumax	Maximum inlet pressure at which the regulator can operate continuously under specific conditions.
REGULATOR	Equipment family.
SG	Lock-up pressure class.
Slam-shut device	Slam-shut valve family.
S.n.	Equipment serial number.
Strength type	Resistance class: Integral strength or differential strength (DS).
T	Permissible temperature range (min. and max.) for which the equipment was designed.
Tripping unit	Pressure switch family.
Type	Accessory type and family.
Wd	Full setpoint range that can be obtained from the regulator by adjusting and/or replacing certain components (e.g. replacement of valve seat or control element, e.g. spring).
Wdo	Full setpoint range as a result of tripping caused by pressure increase in the pressure switch incorporated in the slam-shut valve. This range can be obtained by adjusting and/or replacing the components (for example, spring or sensitive element).
Wds	Full setpoint range that can be obtained from the regulator by adjusting but not replacing the components.
Wdso	Full setpoint range as a result of tripping caused by pressure increase in the pressure switch incorporated in the slam-shut valve. This range can be obtained by adjusting but not replacing the components.
Wdu	Full setpoint range as a result of tripping caused by pressure decrease of the pressure switch incorporated in the slam-shut valve. This range can be obtained by adjusting and/or replacing the components (for example, spring or sensitive element).

Term	Description
Wdsu	Full setpoint range as a result of tripping caused by pressure decrease in the pressure switch incorporated in the slam-shut valve. This range can be obtained by adjusting but not replacing the components.

Tab. 2.6.

2.9 - GLOSSARY OF UNITS OF MEASUREMENT

Type of measurement	Unit of measurement	Description
Volumetric flow rate	Sm ³ /h	Standard cubic metres per hour
	Scfh	Standard cubic feet per hour
Pressure	bar	Unit of measurement in the CGS system
	psi	Pounds per square inch
	"wc	water column inch
	Pa	Pascal
Temperature	°C	Degree centigrade
	°F	Degree Fahrenheit
	K	Kelvin
Tightening torque	Nm	Newton metre
	ft-lbs	Foot per pound
Sound pressure	dB	Decibel
Other measures	V	Volt
	W	Watt
	Ω	Ohm

Tab. 2.7.

2.10 - QUALIFIED PROFESSIONAL FIGURES

Qualified operators in charge of using and managing the equipment throughout its technical service life:

Professional figure	Definition
Mechanical maintenance technician	<p>Qualified technician able to:</p> <ul style="list-style-type: none"> perform preventive/corrective maintenance operations on all mechanical parts of the equipment subject to maintenance or repair; access all device parts for visual inspection, checking equipment status, making adjustments and calibrations. <p>The mechanical maintenance technician is not authorised to operate on live electrical systems (if any).</p>
Electrical maintenance technician	<p>Qualified technician able to:</p> <ul style="list-style-type: none"> perform preventive/corrective maintenance operations on all electrical parts of the device subject to maintenance or repair; read wiring diagrams and check the correct functional cycle; perform adjustments and operate on electrical systems for maintenance, repair and replacement of worn parts. <p>The electrical maintenance technician can operate in the presence of voltage inside electrical panels, junction boxes, control equipment etc. only if he/she is a suitable person (S.P.). For general requirements, refer to the IEC EN 50110-1:2014 standard.</p>
Worker in charge of transport, handling, unloading and placement on site	<p>Qualified operator:</p> <ul style="list-style-type: none"> for the use of lifting equipment; for the handling of materials and equipment. <p>Lifting and handling of the equipment must be carried out strictly in accordance with the instructions provided by the manufacturer and in compliance with the regulations in force at the place where the equipment is installed.</p>
Installer	<p>Qualified operator able to:</p> <ul style="list-style-type: none"> carry out all the operations necessary to properly install the equipment; perform all the operations necessary for the proper functioning of the equipment and the system in safety.
User's technician	<p>Technician trained and authorised to use and manage the equipment for the activities for which it was supplied. They must:</p> <ul style="list-style-type: none"> be able to perform all operations required for the proper functioning of the equipment and the system, and for their safety or that of any personnel present; have proven experience in properly using the equipment similar to that described in this manual, and be trained, informed and instructed in this regard. <p>The technician may carry out maintenance only if authorised/qualified to do so.</p>

Tab. 2.8.

3 - SAFETY

3.1 - GENERAL SAFETY INSTRUCTIONS

WARNING!

The equipment described in this manual is:

- a device subjected to pressure in pressurised systems;
- normally installed in systems carrying flammable gases (for example: natural gas).

WARNING!

If the gas used is a combustible gas, the installation area of the equipment is defined as a “danger zone” as there are residual risks that potentially explosive atmospheres may be generated.

In “danger zones” and in close proximity thereto:

- there must not be any effective sources of ignition;
- smoking is not allowed.

ATTENTION!

Authorised operators must not carry out operations or services on their own initiative that do not fall within their competence.

Never operate the equipment:

- while under the influence of intoxicating substances such as alcohol;
- if you are using drugs that may lengthen reaction times.

NOTICE!

The employer must train and inform operators on how to behave during operations and on the equipment to be used.

Before installation, commissioning or maintenance, operators must:

- take note of the safety regulations applicable to the place of installation that they are working in;
- obtain the necessary permits to operate when required;
- equip themselves with the necessary personal protection required in the procedures described in this manual;
- ensure that the area that they are operating in is equipped with the required collective protections and the necessary safety information.

3.2 - PERSONAL PROTECTIVE EQUIPMENT

Table 3.9 shows the personal protective equipment (PPE) and its description. An obligation is associated with each symbol.

Personal protective equipment means any equipment intended to be worn by the worker in order to protect them against one or more risks that are likely to threaten their safety or health during work.

For the operators in charge, depending on the type of work requested, the most appropriate PPE of the following will be reported and must be used:

Symbol	Meaning
	Obligation to use safety or insulated gloves. Indicates a requirement for personnel to use safety or insulated gloves.
	Obligation to use safety goggles. Indicates a requirement for personnel to use protective goggles for eye protection.
	Obligation to use safety shoes. Indicates a requirement for personnel to use accident-prevention safety shoes.
	Obligation to use noise protection equipment. Indicates a requirement for personnel to use ear muffs or ear plugs to protect their hearing.
	Obligation to wear protective clothing. Indicates a requirement for personnel to wear specific protective clothing.
	Obligation to use a protective mask. Indicates a requirement for personnel to use respiratory masks in the event of a chemical risk.
	Obligation to use a protective helmet. Indicates a requirement for personnel to use the protective helmet.
	Obligation to wear a high visibility vest. Indicates a requirement for personnel to use a high visibility vest.

Tab. 3.9.

WARNING!

Each licensed operator is obliged to:

- **take care of their own health and safety and that of other people present in the workplace, who are affected by their actions or omissions, in accordance with their training, instructions and means provided by the employer;**
- **use the PPE appropriately made available;**
- **immediately report to the employer, the manager or the person in charge of the deficiencies of the means and devices as well as any possible dangerous conditions of which they become aware.**

3.3 - RESIDUAL RISKS

In accordance with the requirements of PED 2014/68/EU, point 1.2 of Annex I, below is an assessment of the risks associated with the equipment and an indication of the principles adopted for their prevention, according to the following classification:

- a) Elimination and/or reduction of the risk.
- b) Application of the appropriate protective measures.
- c) Information to users about residual risks.

3.3.1 - TABLE SHOWING RESIDUAL RISKS DUE TO PRESSURE

Risk and hazard	Event and cause	Effect and consequence	Solution and prevention
Pressurised gas leakage. Projection of metallic and non-metallic pressurised parts.	<ul style="list-style-type: none"> Violent impact; Impact (also due to falling, improper handling, etc.). 	<ul style="list-style-type: none"> Deformation; Broken connections and, if under pressure, even burst. 	a. Handling and installation with appropriate devices to avoid localised stress. b. Installation in suitable places and spaces with appropriate protections, suitable packaging. c. Information in the instructions for use and warning.
Pressurised gas leakage. Projection of metallic and non-metallic pressurised parts.	<ul style="list-style-type: none"> Use of inappropriate fluids. 	<ul style="list-style-type: none"> Corrosion; Embrittlement; Explosion. 	a. The user must check compliance of the used fluid with the specifications on the data plate.
Pressurised gas leakage. Projection of metallic and non-metallic pressurised parts.	<ul style="list-style-type: none"> Operation at temperatures below the minimum permissible temperature. 	<ul style="list-style-type: none"> Embrittlement; Breakage; Explosion. 	a. Install in places where the temperature is not below the minimum permissible temperature and/or insulate the equipment adequately. b. The minimum temperature allowed is indicated on the data plate.
Pressurised gas leakage. Projection of metallic and non-metallic pressurised parts. Explosion.	<ul style="list-style-type: none"> Overpressure or exceeding of the rated limit values (maximum pressure allowed) 	<ul style="list-style-type: none"> Explosion; Breaks; Cracks; Permanent deformations. 	a. The device has appropriate design safety margins. b. The user must check the maximum pressure applicable to the equipment. c. The maximum allowable pressure is highlighted on the appropriate plate on the equipment.
Falling of the equipment.	<ul style="list-style-type: none"> Dangerous handling. 	<ul style="list-style-type: none"> Deformation; Cracking; Breakage. 	b. The user must have suitably sized lifting equipment. c. The above requirements are referred to in the equipment use and warning manual.
Pressurised fluid leakage. Projection of metallic and non-metallic pressurised parts.	<ul style="list-style-type: none"> Incorrect fixing of the equipment. 	<ul style="list-style-type: none"> Deformation; Breakage. 	a. The device is equipped with unified type process connections and compression fittings. b. The user must ensure correct fixing to the line. c. Directions in the instructions for use and warning.
Explosion of the device. Pressurised fluid leakage. Projection of metallic parts.	<ul style="list-style-type: none"> Operation at temperatures above the maximum permissible temperature. 	<ul style="list-style-type: none"> Reduction of mechanical resistance and breakage of the device; Explosion. 	a. The user must equip the system with suitable safety and control devices. b. The maximum temperature allowed is indicated on the data plate.

Risk and hazard	Event and cause	Effect and consequence	Solution and prevention
Pressurised gas leakage.	<ul style="list-style-type: none"> • Device maintenance with the system running. 	<ul style="list-style-type: none"> • Inappropriate opening of pressurised chambers. 	<p>a. The user must perform any maintenance with the equipment not in operation.</p> <p>b. The above requirements are referred to in the use and warning manual.</p>
Pressurised gas leakage. Projection of metallic and non-metallic pressurised parts.	<ul style="list-style-type: none"> • External loads bearing on the device. 	<ul style="list-style-type: none"> • Deformation; • Cracking and slot formation; • If under pressure, even burst. 	<p>a. With the exclusion of what is set out in the project, the user must verify that no additional concentrated load bears on the device.</p>
Pressurised gas leakage. Projection of metallic and non-metallic pressurised parts.	<ul style="list-style-type: none"> • Electrostatic potential, differential stray currents. 	<ul style="list-style-type: none"> • Corrosion localised in the device. 	<p>b. The user must equip the device with the necessary protection and earthing devices.</p> <p>c. The above requirements are referred to in the use and warning manual.</p>
Pressurised gas leakage. Projection of metallic and non-metallic pressurised parts.	<ul style="list-style-type: none"> • Humidity; • Environments with aggressive atmosphere. 	<ul style="list-style-type: none"> • Deterioration of external surfaces; • Corrosion. 	<p>a. The user must periodically check the state of conservation of the external surfaces.</p> <p>b. The above requirements are referred to in the use and warning manual.</p>

Tab. 3.10.

3.3.2 - TABLE OF RESIDUAL RISKS FOR POTENTIALLY EXPLOSIVE ATMOSPHERES

Table 3.11 shows the conditions that can lead to the generation of a potentially explosive atmosphere respectively for:

- the NORVAL pressure regulator;
- the ER monitor;
- the SN slam-shut valve.

Considering that the silencer does not have active functional parts, in this analysis it is considered an integral part of the NORVAL regulator.

The table is valid for use with natural gas with a density of no more than 0.8; for different densities, the installation and environmental conditions must also be evaluated.

WARNING!

If the gas used is a combustible gas, the installation area of the equipment is defined as a “danger zone” as there are residual risks that potentially explosive atmospheres may be generated. There must be no effective sources of ignition in “danger zones” and in close proximity thereto.

Operating conditions	Potentially explosive atmosphere	Normative references	Management measures included in the instructions for use and warning
First start-up	No	<ul style="list-style-type: none"> • During the production cycle and before the CE marking according to Directive 2014/68/EU, the external tightness of the equipment is checked at a value of 1.1 PS (in accordance with Standard EN 334). • Before commissioning, the external tightness of the portion of the system on which the equipment is installed is checked at a suitable pressure (in accordance with standards EN 12186 and EN 12279). 	The instructions for use indicate the need to meet the requirements of Standards EN 12186 and EN 12279.
Operation under normal conditions	No	<p>The indications in the previous point apply, in addition:</p> <ul style="list-style-type: none"> • the equipment is installed outdoors or in an environment with natural ventilation (in accordance with Standards EN 12186 and EN 12279); • the installation is subject to surveillance according to current national rules/good practice/the equipment manufacturer's instructions (in accordance with the provisions of Standard EN 12186 and Standard EN 12279). 	<p>The instructions for use indicate that:</p> <ul style="list-style-type: none"> • any environment in which the equipment is installed must meet the requirement of Standards EN 12186 and EN 12279; • periodic checks and maintenance must be carried out during surveillance in accordance with the national rules in force (if any), and with the specific manufacturer's recommendations.

Operating conditions	Potentially explosive atmosphere	Normative references	Management measures included in the instructions for use and warning
Breakage of the control head diaphragm (malfunction)	No	<p>This event must be considered a rare malfunction.</p> <p>All atmospheric pressure chambers delimited on at least one side by a diaphragm must be channelled to a safe area (in accordance with the provisions of Standard EN 12186 and Standard EN 12279).</p>	<p>The instructions for use indicate the need to meet the requirements of Standards EN 12186 and EN 12279.</p>
Breakage of other non-metallic parts (malfunction)	No	<p>This type of malfunction is not reasonably expected as it involves static sealing (to the outside).</p>	-
Decommissioning	No	<ul style="list-style-type: none"> The pressure of the system section in which the equipment is installed must be reduced with appropriate vent lines channelled to a safe area (in accordance with the provisions of Standard EN 12186 and Standard EN 12279). The residual gas must be discharged as indicated above. 	<p>The instructions for use indicate the need to meet the requirements of Standards EN 12186 and EN 12279</p>
Reboot	No	<ul style="list-style-type: none"> After reassembling the regulator, carry out an external leakage test at a convenient pressure value as specified by the manufacturer. Before commissioning, the external tightness of the portion of the system on which the equipment is installed is checked at a suitable pressure (in accordance with standards EN 12186 and EN 12279). 	<p>The instructions for use indicate:</p> <ul style="list-style-type: none"> the minimum conditions for testing internal leakage; the need to meet the requirements of Standards EN 12186 and EN 12279.

Tab. 3.11.

3.4 - OBLIGATIONS AND PROHIBITIONS

The following is a list of obligations and prohibitions to be observed for the safety of the operator.

It is mandatory to:



- carefully read and understand the instructions for use and warning;
- check whether the downstream equipment is suitably sized according to the performance required of the regulator in the actual operating condition;
- before installing the equipment, the data on the nameplates must be checked;
- Avoid violent shocks and impacts that could damage the equipment and, as a result, cause the pressure fluid to escape.

It is forbidden to:

- operate in various capacities on the equipment without the PPE indicated in the work procedures described in these use and warning instructions;
- operate in the presence of open flames or bring open flames close to the work area;
- smoke near the equipment or while working on it;
- use the equipment with parameters other than those indicated on the nameplate;
- use the equipment with fluids other than those indicated on the nameplate and in these use and warning instructions;
- use the equipment outside the operating temperature range declared on the identification plate and in these use and warning instructions;
- service the equipment with the portion of the system on which it is installed in operation;
- install or use the equipment in environments other than those specified in these instructions for use and warning.

3.5 - SAFETY PICTOGRAMS

The following safety pictograms may be shown on the equipment and/or packaging PIETRO FIORENTINI S.p.A.:

Symbol	Definition
	Symbol used to identify an ELECTRICAL HAZARD.
	Symbol used to identify a GENERIC HAZARD.

Tab. 3.12.

HAZARD!

It is absolutely forbidden to remove the safety pictograms on the equipment.

The user is required to replace the safety pictograms which, following wear, removal or tampering, are illegible.

3.6 - NOISE LEVEL

Depending on the operating conditions, use and configuration required, the equipment may generate noise beyond the limits allowed by current legislation in the country of installation.

For the value of the noise generated by the equipment and further information, contact PIETRO FIORENTINI S.p.A.

ATTENTION!

The obligation to use ear muffs or ear plugs to protect the operator's hearing remains in the event that the noise in the installation environment of the equipment (depending on specific operating conditions) exceeds the value of 85 dBA.

4 - DESCRIPTION AND OPERATION

4.1 - GENERAL DESCRIPTION

The NORVAL equipment is a direct acting pressure regulator for medium and low pressure which reduces the inlet gas pressure, keeping the downstream value stable even when the following varies:

- inlet pressure value
- the required flow rate within the operating conditions of the equipment.

The main elements of the equipment are (see fig.4.1.):

Pos.	Description	Pos.	Description
1	Regulator body	4	Rod
2	Setting spring	5	Valve seat
3	Main diaphragm	6	Plug with reinforced gasket

Tab. 4.13.

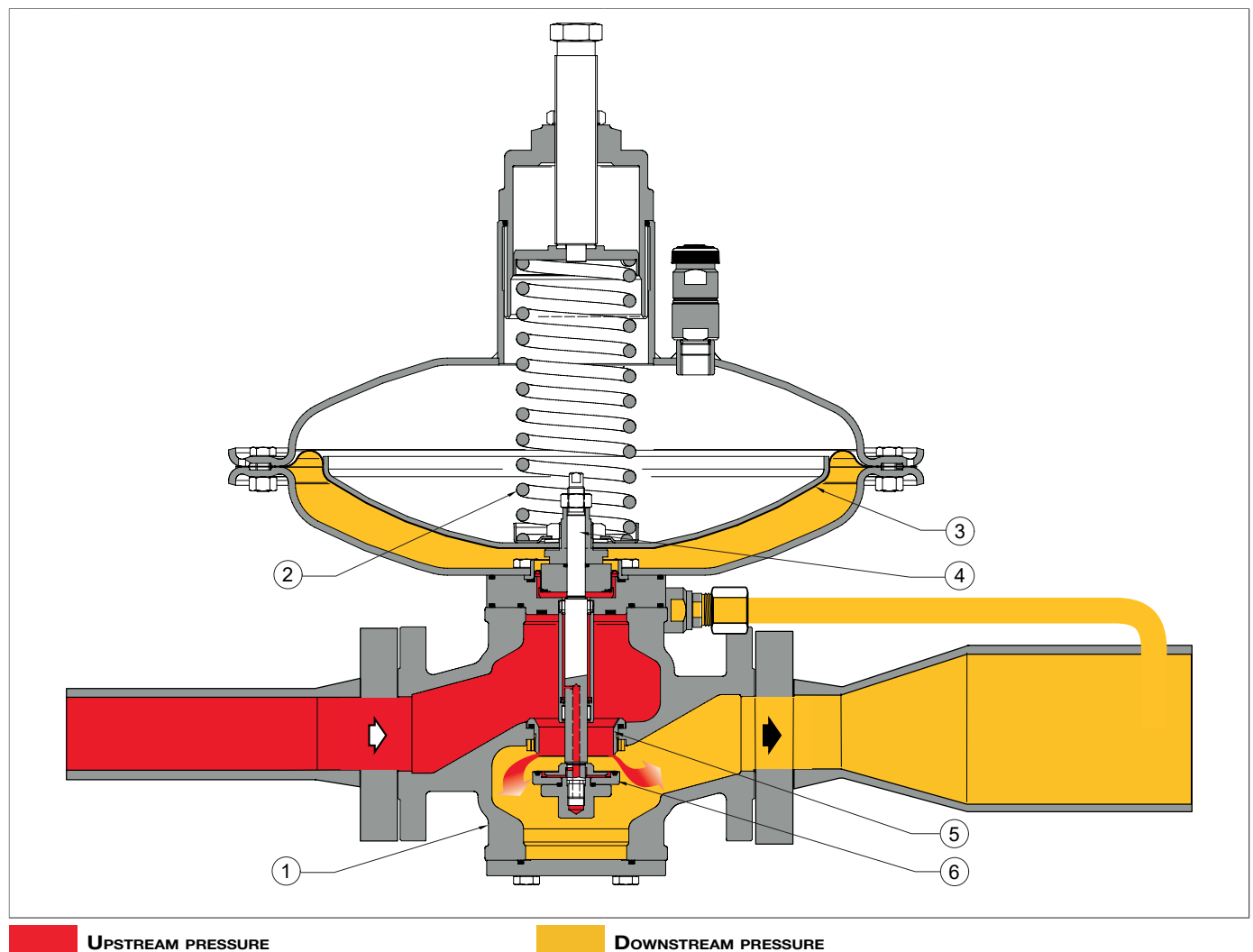

Fig. 4.1. General description NORVAL

4.1.1 - REGULATOR REACTION MODES

The NORVAL equipment is a direct acting regulator with a “fail open” reaction (on-opening reaction), that is, it opens in the event of:

- breakage of main diaphragm
- downstream pressure signal missing

4.2 - OPERATION

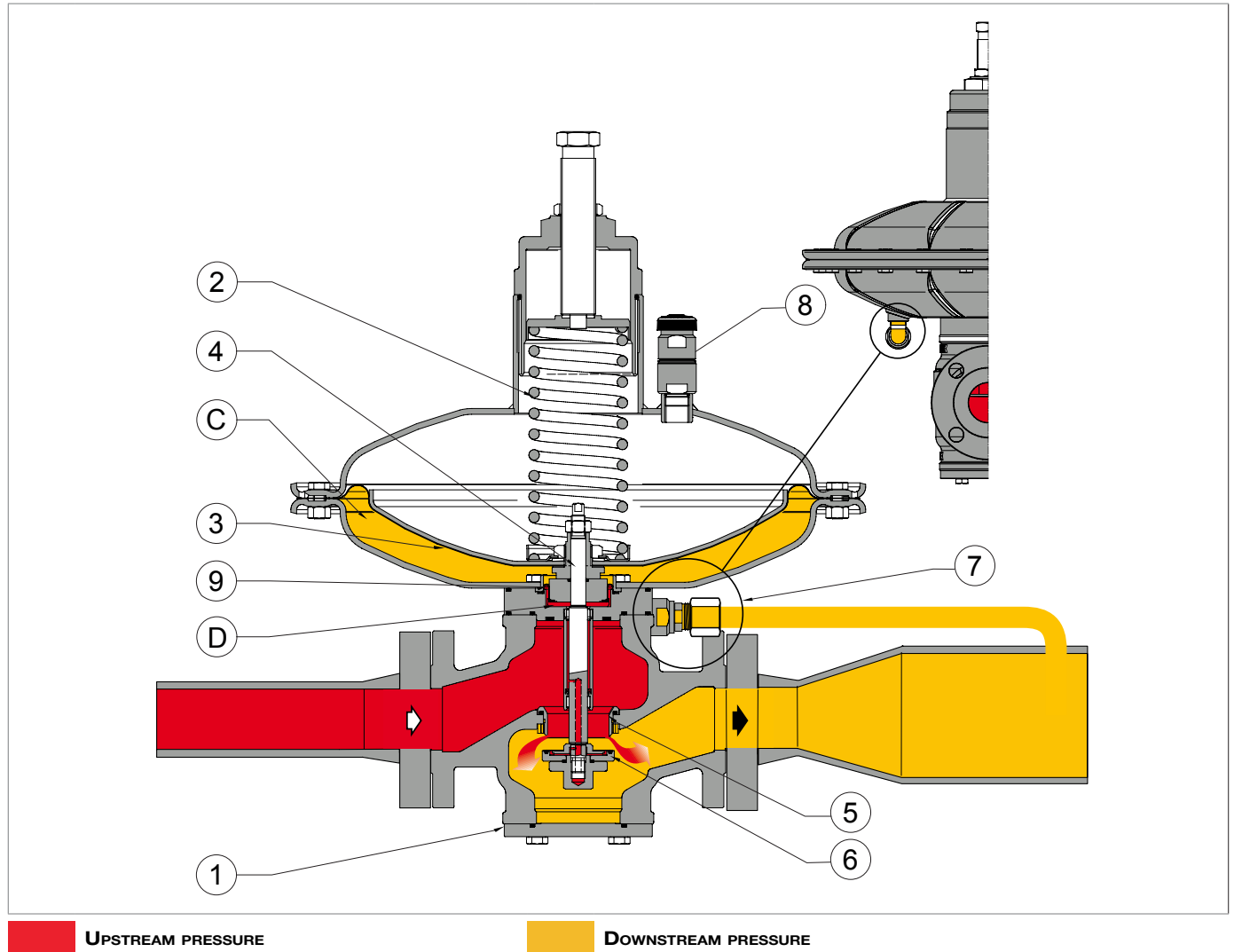

Fig. 4.2. NORVAL Operation

In depressurised conditions, the plug (6) is kept in an open position by the spring (2).

The downstream pressure value (P_d) is regulated by comparing:

- the load of the setting spring (2);
- the thrust of the main diaphragm (3) resulting from downstream pressure (P_d).

The main diaphragm (3) moves the rod (4), joined to the plug (6). The rod (4) moves perpendicularly with respect to the gas flow. The reinforced gasket secured to the plug (6) seals the regulator when there is zero flow rate.

Under normal work conditions, the plug (6) positions itself so as to keep the pressure downstream (P_d) around the pre-established calibration value.

The position of the plug (6) is controlled by movements of the main diaphragm (3) and of the balancing diaphragm (9). The forces which affect the position of the plug (6) are:

- towards the closed position: the thrust resulting from the downstream pressure (P_d) in the chamber (C) and in the chamber (D)
- towards the open position: the load of the setting spring (2).

The weight of the mobile unit acts towards the closed or open position depending on where the regulator is installed.

Variations in the pressure upstream (P_u) do not modify the value of the pressure downstream (P_d) since the mobile equipment is completely balanced.

If, during operation, the following should occur:

Operating conditions	Operating consequences	Concluding outcome
Decrease in pressure downstream (P_d) due to: <ul style="list-style-type: none"> • increase in the requested flow rate; • drop in pressure upstream (P_u). 	Unbalance that causes the plug (6) to open.	Increase in the flow rate until the pre-established calibration value of the downstream pressure (P_d) is restored.
Increase in pressure downstream (P_d) due to: <ul style="list-style-type: none"> • drop in the requested flow rate; • increase in pressure upstream (P_u). 	Unbalance that causes the plug (6) to close.	Decrease in the flow rate until the pre-established calibration value of the downstream pressure (P_d) is restored.

Tab. 4.14.

4.2.1 - ANTI-PUMPING VALVES (VAP)

The anti-pumping valves (7, 8, fig. 4.2) are located in the sensing line of downstream pressure (P_d) and at the top of the regulator head.

The anti-pumping valves slow down the inflow and outflow of gas in the head during transitional phases. Their function is to minimise the effects caused by quick variations of the requested flow rate (quick variations of the downstream pressure (P_d)) on the behaviour of the regulator.

The main elements are (see fig. 4.3):

Pos.	Description	Pos.	Description
1	Fitting	4	Plug assembly
2	Valve body	5	Indicator O-ring in the VAP version
3	Sealing O-ring		

Tab. 4.15.

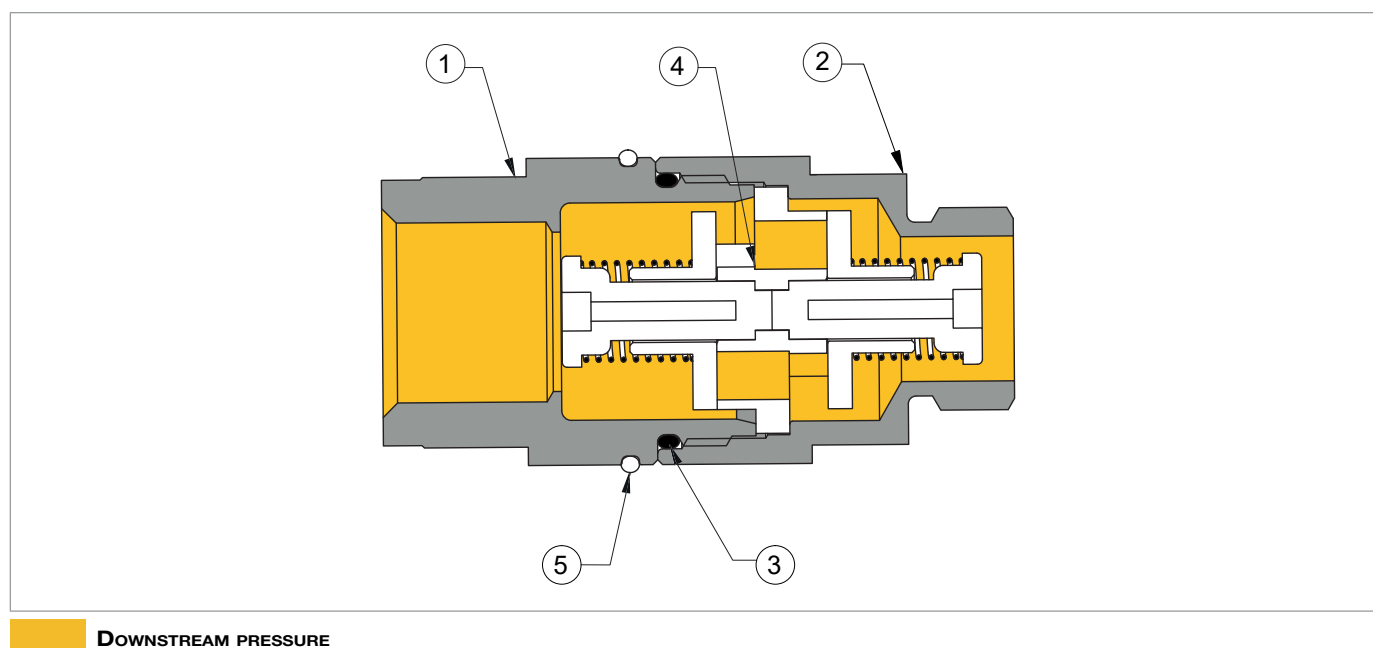

Fig. 4.3. NORVAL Operation

4.3 - INTENDED USE

4.3.1 - ENVISAGED USE

The equipment in question is intended for:

Operation	Permitted	Not permitted	Work environment
Adjustment of the downstream pressure for:	Gaseous, and non-corrosive, fluids that have been filtered beforehand.	<ul style="list-style-type: none"> Liquids. Any product other than those permitted. 	Installations for the transport and distribution of gas fuel to supply networks for: <ul style="list-style-type: none"> civil use; industrial use.

Tab. 4.16.

The equipment in question is used as a main regulator and in-line monitor regulator.

It is designed to be used exclusively within the limits specified on the nameplate and according to the instructions and limits of use referred to in this manual.

Safe work parameters are:

- use within the limits stated on the nameplate and in this manual;
- compliance with the user manual procedures;
- routine maintenance to be carried out when and how recommended;
- special maintenance to be carried out if required;
- do not tamper with and/or bypass the safety devices.

4.3.2 - REASONABLY FORESEEABLE MISUSE

Incorrect and reasonably foreseeable use means the use of the equipment in a way not foreseen in the design phase but which can result from readily predictable human behaviour:

- corrosive fluids;
- fluids not properly treated upstream;
- liquids;
- instinctive reaction of an operator in the event of a malfunction, accident or breakdown while using the equipment;
- behaviour resulting from pressure to keep the equipment running under all circumstances;
- behaviour resulting from carelessness;
- behaviour resulting from the use of the equipment by unauthorised and unsuitable people;
- using the equipment in a manner other than that referred to under "Intended use".

Any use of the equipment other than the intended use must be previously approved in writing by PIETRO FIORENTINI S.p.A. If no written approval is provided, use shall be considered improper.

In the event of "improper use", PIETRO FIORENTINI S.p.A. shall not be held liable for any damage caused to people or property, and any type of warranty on the equipment shall be deemed void.

4.3.3 - TYPES OF FLUIDS

The equipment works with combustible gases used:

- in pressure control stations according to EN 12186 or EN 12279;
- in transmission and distribution networks.
- in commercial and industrial plants (after checking by contacting the Manufacturer).

NOTICE!

The equipment may be also used with inert gases, subject to verification by contacting the manufacturer.

4.4 - TECHNICAL FEATURES/PERFORMANCE

The NORVAL equipment is a medium and low pressure regulator. The regulation system is balanced and guarantees a stable outlet pressure even when the inlet pressure and the requested flow rate vary.

The main specifications for this regulator are:

Technical features	
Maximum allowable pressure	Up to 18.9 bar
Inlet gas temperature range	-20 °C - +60 °C
Ambient temperature range	-20 °C - +60 °C
Inlet pressure range (bpu)	<ul style="list-style-type: none"> • DN 1" - 3": 0.1 - 18.9 bar • DN 4" - 8": 0.1 - 8 bar
Possible regulation range (Wd)	<ul style="list-style-type: none"> • DN 1" - 4": 0.008 - 4.4 bar • DN 6", 8": 0.012 - 1.8 bar
Minimum differential pressure	0.1 bar
Accuracy class (AC)	up to 5 (depending on operating conditions)
Lock up pressure class (SG)	up to 10 (depending on operating conditions)

Tab. 4.17.

Cg, Kg and K1 coefficients								
Nominal diameter [mm]	25	40	50	65	80	100	150	200
Size [inches]	1"	1" 1/2	2"	2" 1/2	3"	4"	6"	8"
Coefficient Cg	331	848	1360	2240	3395	5100	10600	16600
Coefficient K1	106.78	106.78	106.78	106.78	106.78	106.78	106.78	106.78

Tab. 4.18.

4.5 - POSSIBLE CONFIGURATIONS

4.5.1 - CONTROL HEADS

Table 4.19 lists the possible combinations of sizes and control heads for the NORVAL equipment.

		DN							
		1"	1" ½	2"	2" ½	3"	4"	6"	8"
HEADS	375TR	Yes	Yes	Yes	Yes	Yes	Yes	-	-
	375	Yes	Yes	Yes	Yes	Yes	Yes	-	-
	495	Yes	Yes	Yes	Yes	Yes	Yes	Yes	Yes
	630	-	-	-	Yes	Yes	Yes	Yes	Yes
	658	-	-	-	-	-	-	Yes	Yes
	817	-	-	-	-	-	-	Yes	Yes

Tab. 4.19.

4.5.2 - ACCESSORIES

The NORVAL equipment can have different configurations through the installation of the following accessories:

- Regulator with monitor function with ER device
- Incorporated SN slam-shut valve.

The possible configurations are listed in table 4.20:

NORVAL	Regulator-monitor with ER	SN
Regulator-monitor with ER	-	Yes
Incorporated SN slam-shut valve	Yes	-

Tab. 4.20.

The accessories can be installed directly at the factory or, at a later time, directly on site.



NOTICE!

The installation of accessories is described in the relevant chapter of this manual.

4.5.3 - REGULATOR WITH MONITOR FUNCTION WITH ER DEVICE

The regulator with monitor function is used to keep the downstream pressure value (P_d) within the preset limits in case of failure of the main regulator.

The regulator with monitor function is installed upstream of the main pressure regulator.

The regulator with monitor function is a regulator which, in addition to the normal version, has a balancing device (ER device (1), see fig. 4.4) of the mobile equipment. The ER device (1) is installed on the lower flange of the monitor regulator (2).

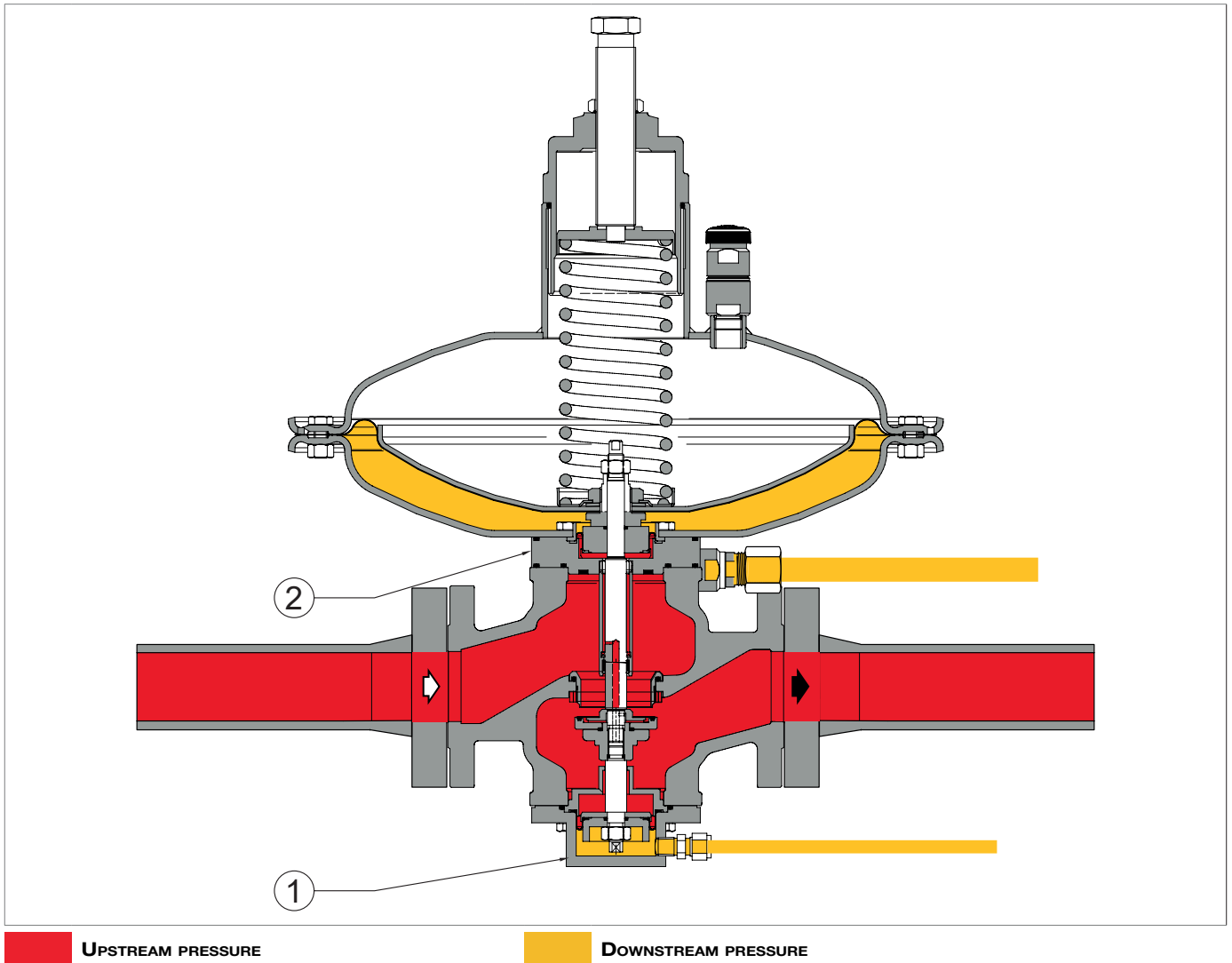

Fig. 4.4. Regulator with monitor function with ER device

4.5.3.1 - REGULATOR WITH IN LINE MONITOR FUNCTION

The regulator with monitor function with ER device (1) is mounted in series on the same line as the main regulator (2). The two regulators are functionally independent and are controlled by independent sensing lines.

OPERATION IN STAND-BY CONDITIONS

The regulator with monitor function with ER device (1) is open during normal operation since it is calibrated higher than the calibration of the main regulator (2).

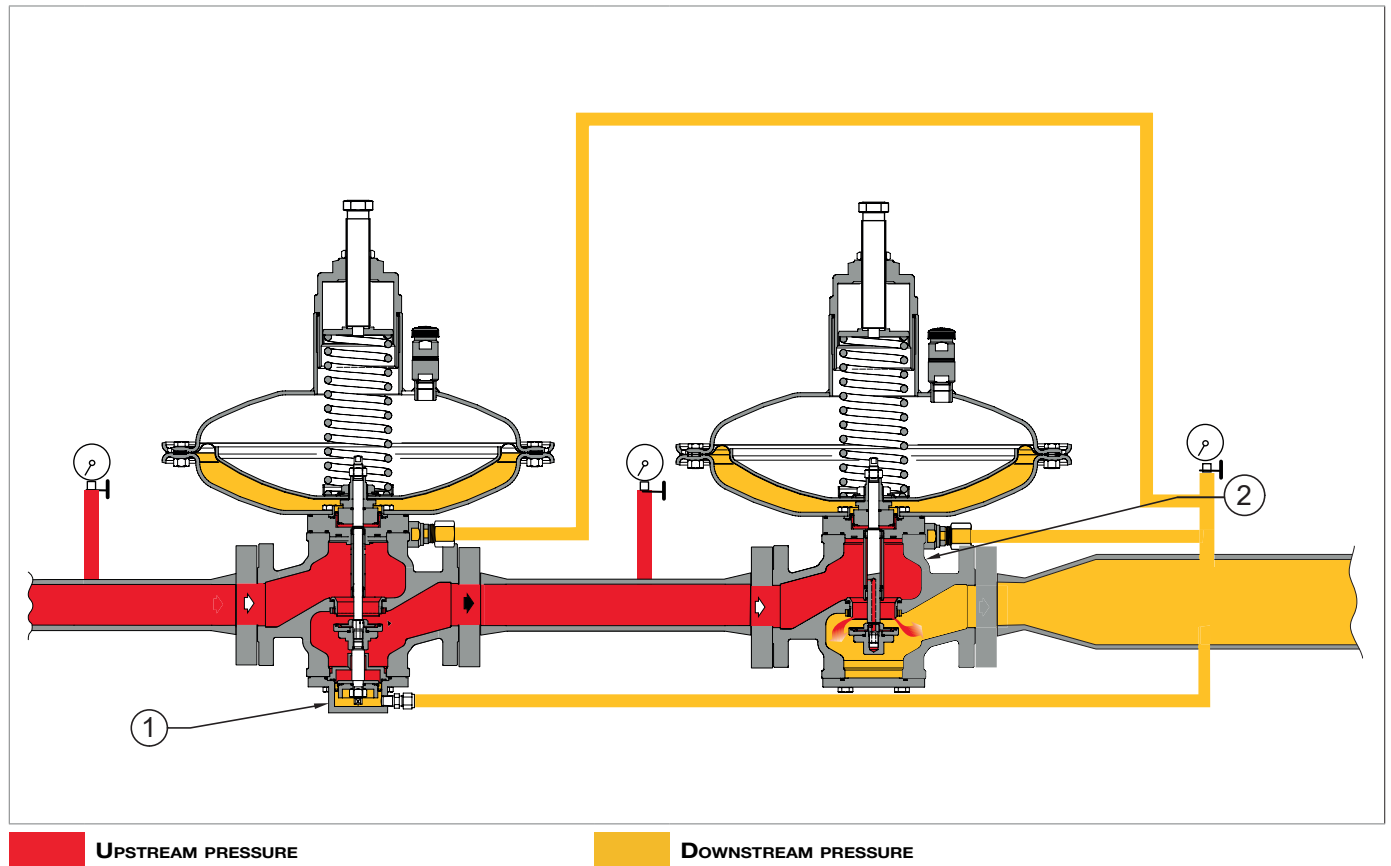

Fig. 4.5. In-line operation of regulator-monitor + ER in stand-by conditions

OPERATION IN THE EVENT OF FAILURE OF THE MAIN REGULATOR

Fig. 4.6. Operation of regulator-monitor + ER with main regulator in faulty conditions

In the event of failure of the main regulator (2), the regulator with monitor function with ER device (1) will intervene maintaining the downstream pressure value (P_d) within the established limit for its calibration.

If, during operation, the following should occur:

Operating conditions	Operating consequences	Concluding outcome
Decrease in pressure downstream (P_d) due to: <ul style="list-style-type: none"> • increase in the requested flow rate; • drop in pressure upstream (P_u). 	Unbalance that causes the plug (3) to open.	Increase in the flow rate until the pre-established calibration value of the downstream pressure (P_d) is restored.
Increase in pressure downstream (P_d) due to: <ul style="list-style-type: none"> • drop in the requested flow rate; • increase in pressure upstream (P_u). 	Unbalance that causes the plug (3) to close.	Decrease in the flow rate until the pre-established calibration value of the downstream pressure (P_d) is restored.

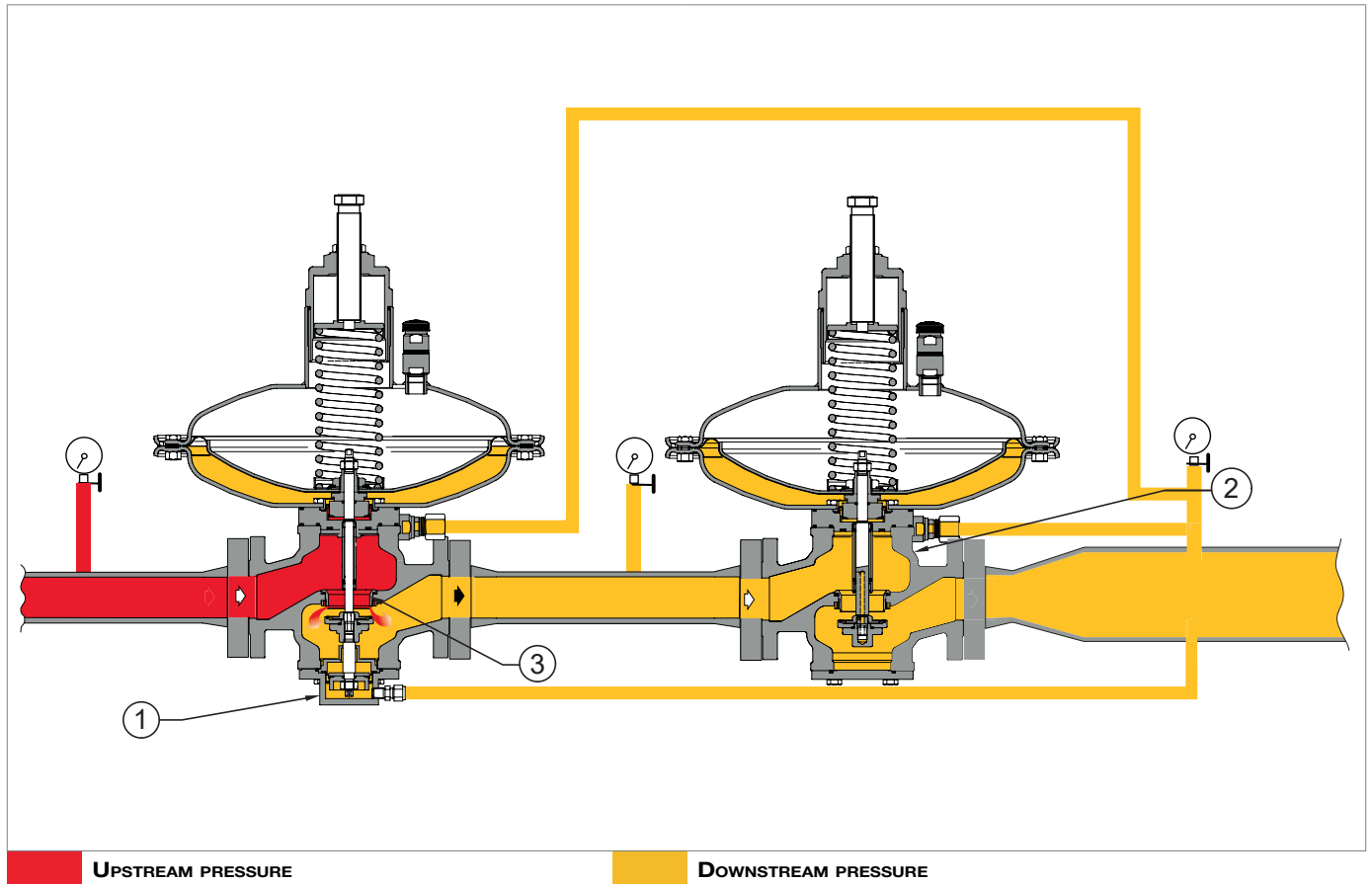
Tab. 4.21.

4.5.4 - SLAM-SHUT VALVE

The slam-shut valve is a safety device is used to shut off the gas flow if the pressure value at the control point exceeds the calibration value of the valve itself.

The slam-shut valve incorporated in the main regulator consists of:

- a control system
- a locking mechanism.

4.5.4.1 - INCORPORATED SN SLAM-SHUT VALVE

The incorporated SN slam-shut valve is controlled by a control pressure switch (see tab. 4.22) and can be actuated:

- by the pressure switch
- manually
- with remote control.

The main features of the incorporated SN slam-shut valve are:

- tripping due to downstream pressure increase (max) and/or decrease (min)
- design pressure: 18.9 bar for all accessory components
- local closing button
- resetting without need for external bypass of the regulation line.

Pressure switch type	Set	Tripping range (bar)	AG
SN-91	max	0.025 - 1.1	10
SN-92	max	0.7 - 2	10
	max	2 - 5	5

Tab. 4.22.

* For tripping ranges due to pressure decrease (min) and for the inverted version of the regulator with slam-shut device, refer to chapter 13 "Calibration tables"

The incorporated SN slam-shut valve consists of (see fig. 4.7):

Pos.	Description
1	Plug
2	Valve seat
3	Coupling device
4	Control pressure switch
5	Pressure switch diaphragm
6	Sensor
7	Control shaft
8	Tripping spring due to pressure increase (max)
9	Tripping spring due to pressure decrease (min)
10	Reset lever

Tab. 4.23.

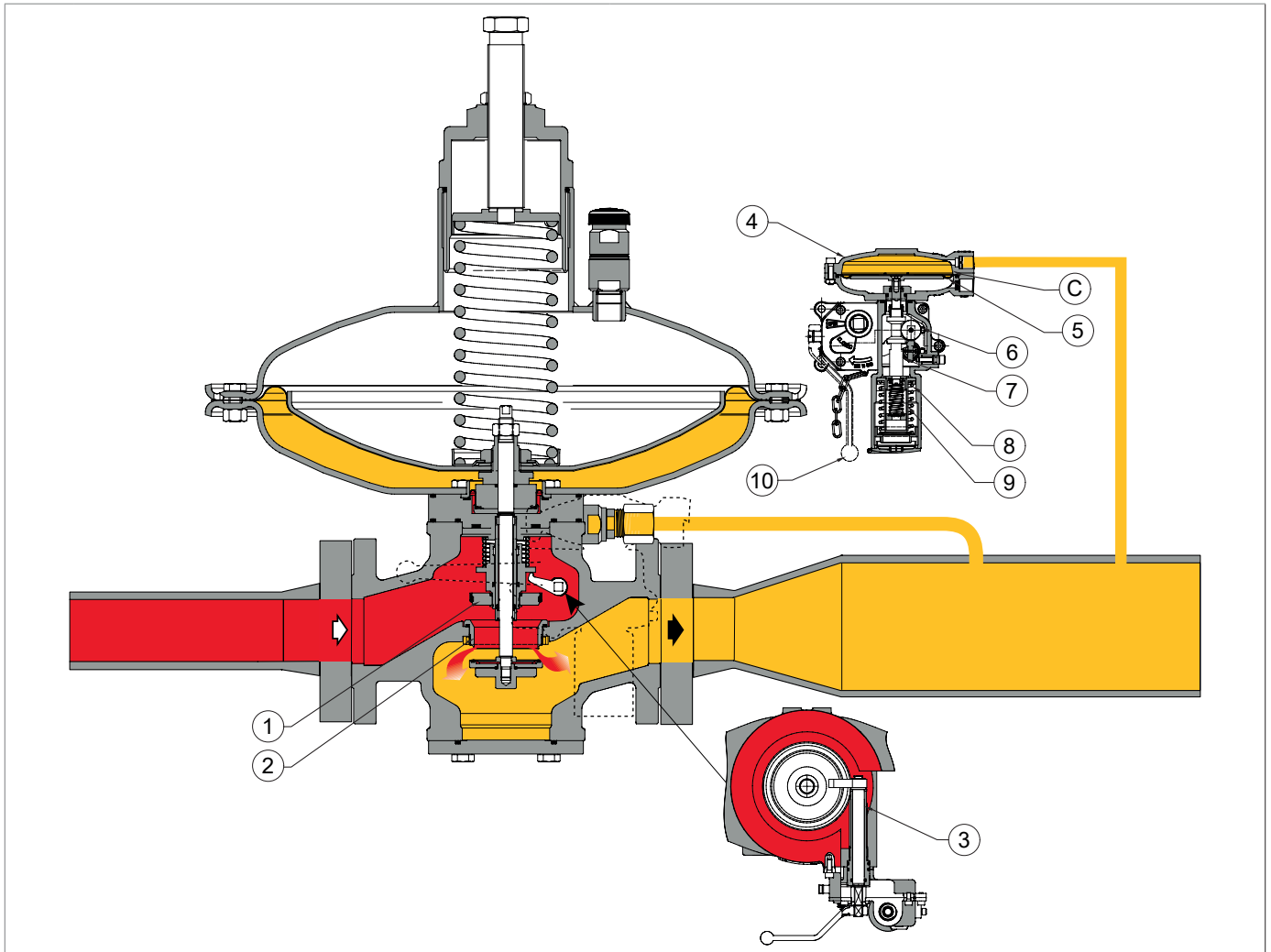

Fig. 4.7. NORVAL with SN slam-shut valve

OPERATION

The downstream pressure (P_d) in the control head (C) acts on the diaphragm (5) of the control pressure switch (4), which, joined to the control shaft (7), receives an opposite force from the spring (8, 9), which determines the release of the plug (1) on the valve seat (2).

In case of tripping due to pressure increase:

- the downstream pressure (P_d) exceeds the calibration value
- the load on the diaphragm (5) increases until it overcomes the resistance of the spring (8)
- the translation of the control shaft (7) which through the cam, moves the sensor (6), while releasing the coupling device (3).

In case of tripping due to pressure decrease:

- the downstream pressure (P_d) drops below the calibration value
- the spring support (9) stops the stroke on the body stop
- the translation of the control shaft (7) which through the cam, moves the sensor (6), while releasing the coupling device (3).

To reset the SN slam-shut valve, act on the lever (10) which:

- opens an internal bypass in the first section of the stroke allowing the upstream pressure (P_u) to be transferred from the inlet chamber to the outlet chamber of the regulator body thereby rebalancing the pressure on the plug (1);
- in the second section of the stroke, re-couples the coupling device (3) of the mobile system.

5 - TRANSPORT AND HANDLING



5.1 - SPECIFIC WARNINGS FOR TRANSPORT AND HANDLING

NOTICE!

Transport and handling must be carried out by personnel:

- qualified (specially trained);
- who are familiar with accident prevention and workplace safety regulations;
- authorised to use lifting equipment;
- in compliance with the regulations in force in the country of destination of the equipment.

Transport with forklift or crane

Operator qualification	Person in charge of transport, handling, unloading and placing on site
PPE required	 <p> WARNING!</p> <p>The PPE listed in this table is related to the risk associated with the equipment. For the PPE required to protect against risks associated with the workplace, installation or operating conditions, please refer to:</p> <ul style="list-style-type: none"> • the regulations in force in the country of installation; • <u>any information provided by the Safety Manager at the installation facility.</u>
Lifting equipment	Hoist crane, forklift truck or other suitable equipment.
Weights and dimensions of the equipment	For dimensions and weights, refer to paragraph 5.2 "Physical characteristics of the equipment".

Tab. 5.24.

5.1.1 - PACKAGING AND FASTENERS USED FOR TRANSPORT

The transport packaging is designed and manufactured to avoid damage during normal transport, storage and handling. The equipment and spare parts must be kept in their packaging until they are installed.



Upon receiving the equipment:

- make sure that no part has been damaged during transport and/or handling;
- immediately report any damage found to PIETRO FIORENTINI S.p.A..

! NOTICE!

PIETRO FIORENTINI S.p.A. shall not be liable for any damage to people or property caused by accidents due to failure to comply with the instructions provided in this manual.

Table 5.25 shows the types of packaging used:

Ref.	Type of packaging	Image
A	Cardboard box	
B	Wooden box	
C	Pallet	

Tab. 5.25.

5.2 - PHYSICAL CHARACTERISTICS OF THE EQUIPMENT

5.2.1 - NORVAL

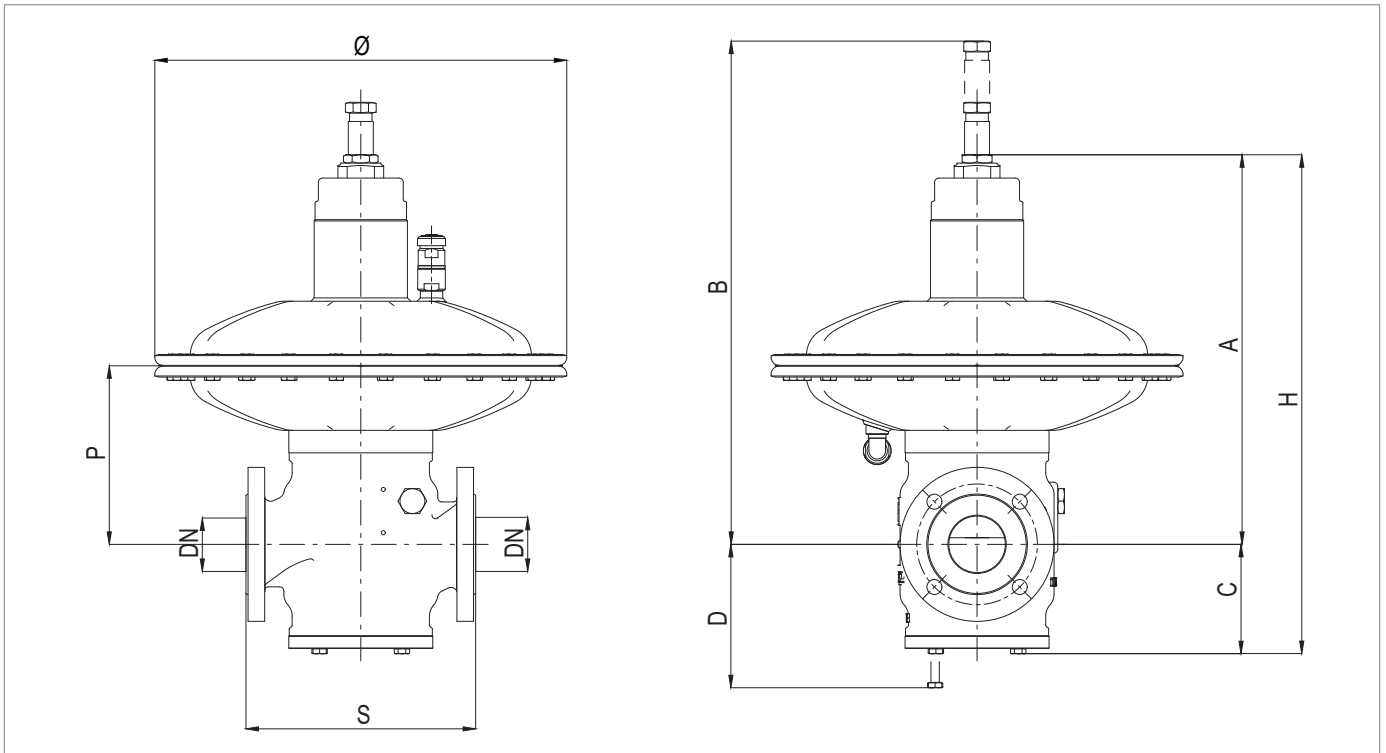

Fig. 5.8. NORVAL physical characteristics

NORVAL overall dimensions								
Nominal diameter [mm]	25	40	50	65	80	100	150	200
Size [inches]	1"	1" 1/2	2"	2" 1/2	3"	4"	6"	8"
S - Class 150	183	223	254	277	298	532	451	543
A with Ø 375TR	425	445	445	465	465	565	-	-
A with Ø 375	415	435	435	455	455	555	-	-
A with Ø 495	460	475	475	500	500	600	670	770
A with Ø 630	-	-	-	540	540	640	675	775
A with Ø 658	-	-	-	-	-	-	720	820
A with Ø 817	-	-	-	-	-	-	760	860
B with Ø 375TR	595	615	615	635	635	735	-	-
B with Ø 375	585	605	605	625	625	725	-	-
B with Ø 495	630	645	645	670	670	770	840	940
B with Ø 630	-	-	-	710	710	810	845	945
B with Ø 658	-	-	-	-	-	-	890	990
B with Ø 817	-	-	-	-	-	-	930	1030
C	100	120	120	140	140	180	220	230
D	140	160	160	180	180	220	260	300
H with Ø 375TR	525	565	575	605	505	745	-	-
H with Ø 375	515	555	555	595	595	735	-	-
H with Ø 495	560	595	595	640	640	780	890	1200
H with Ø 630	-	-	-	680	680	820	895	1105
H with Ø 658	-	-	-	-	-	-	940	1250
H with Ø 817	-	-	-	-	-	-	980	1290
P with Ø 375TR	155	170	170	195	195	280	-	-
P with Ø 375	150	165	165	190	190	275	-	-
P with Ø 495	175	190	190	210	210	300	375	475
P with Ø 630	-	-	-	220	220	310	380	480
P with Ø 658	-	-	-	-	-	-	380	480
P with Ø 817	-	-	-	-	-	-	400	500
Connecting pneumatic pipes	<ul style="list-style-type: none"> Recommended standard for control heads: Øe 14mm x Øi 12mm Recommended standard for SN pressure switch and ER device: Øe 10mm x Øi 8mm 							

Tab. 5.26.

Weight [kgf]								
Class 150	44	48	50	75	92	121	206	291

Tab. 5.27.

5.2.2 - NORVAL + ER

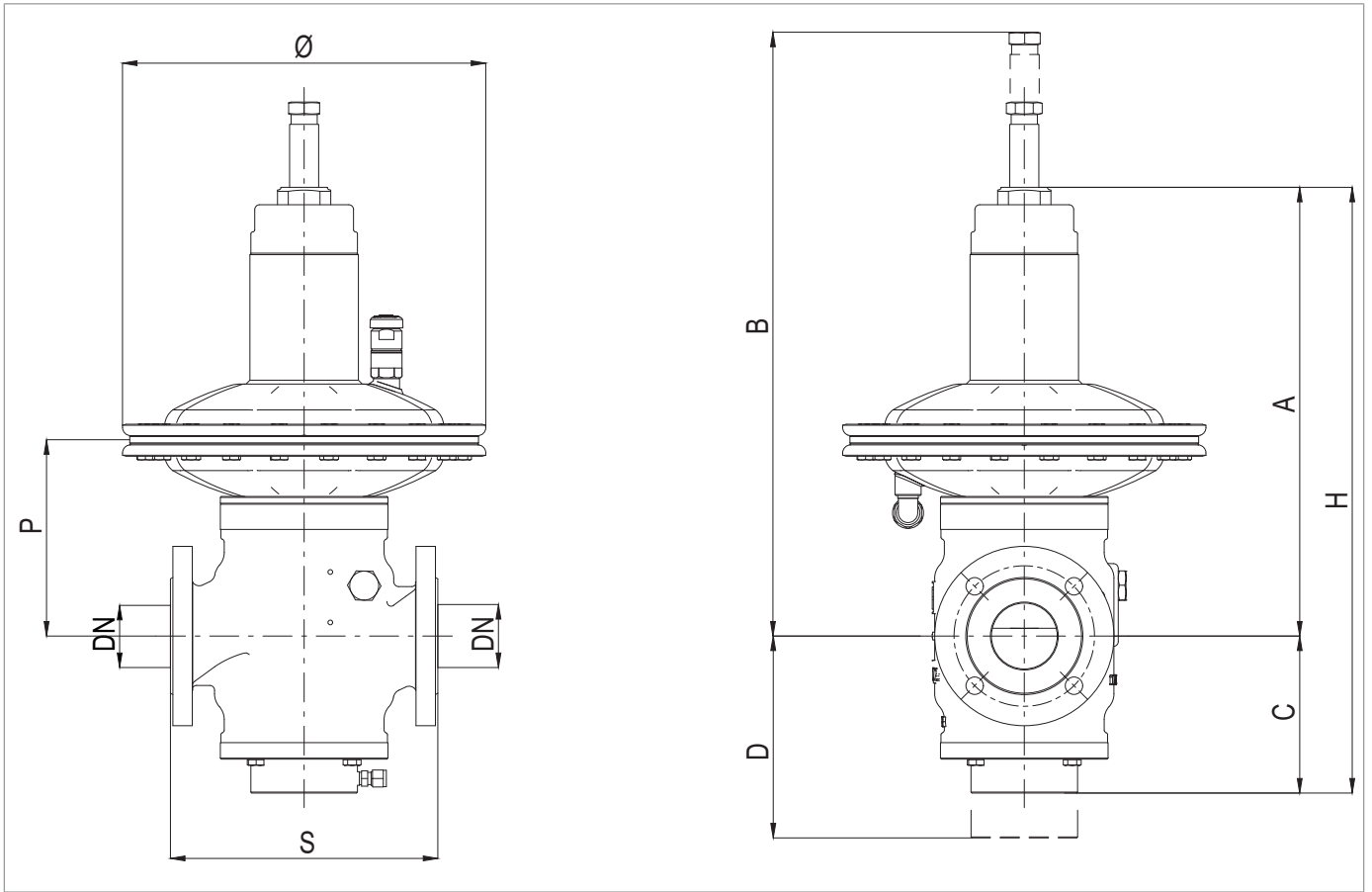

Fig. 5.9. NORVAL + ER physical characteristics

NORVAL overall dimensions								
Nominal diameter [mm]	25	40	50	65	80	100	150	200
Size [inches]	1"	1" 1/2	2"	2" 1/2	3"	4"	6"	8"
S - Class 150	183	223	254	277	298	532	451	543
A with Ø 375TR	425	445	445	465	465	565	-	-
A with Ø 375	415	435	435	455	455	555	-	-
A with Ø 495	460	475	475	500	500	600	670	770
A with Ø 630	-	-	-	540	540	640	675	775
A with Ø 658	-	-	-	-	-	-	720	820
A with Ø 817	-	-	-	-	-	-	760	860
B with Ø 375TR	595	615	615	635	635	735	-	-
B with Ø 375	585	605	605	625	625	725	-	-
B with Ø 495	630	645	645	670	670	770	840	940
B with Ø 630	-	-	-	710	710	810	845	945
B with Ø 658	-	-	-	-	-	-	890	990
B with Ø 817	-	-	-	-	-	-	930	1030
C	100	120	120	140	140	180	220	230
D	140	160	160	180	180	220	260	300
H with Ø 375TR	525	565	575	605	505	745	-	-
H with Ø 375	515	555	555	595	595	735	-	-
H with Ø 495	560	595	595	640	640	780	890	1200
H with Ø 630	-	-	-	680	680	820	895	1105
H with Ø 658	-	-	-	-	-	-	940	1250
H with Ø 817	-	-	-	-	-	-	980	1290
P with Ø 375TR	155	170	170	195	195	280	-	-
P with Ø 375	150	165	165	190	190	275	-	-
P with Ø 495	175	190	190	210	210	300	375	475
P with Ø 630	-	-	-	220	220	310	380	480
P with Ø 658	-	-	-	-	-	-	380	480
P with Ø 817	-	-	-	-	-	-	400	500
Connecting pneumatic pipes	<ul style="list-style-type: none"> Recommended standard for control heads: Øe 14mm x Øi 12mm Recommended standard for SN pressure switch and ER device: Øe 10mm x Øi 8mm 							

Tab. 5.28.

Weight [kgf]								
Class 150	48	55	58	85	100	129	216	302

Tab. 5.29.

5.2.3 - NORVAL + SN

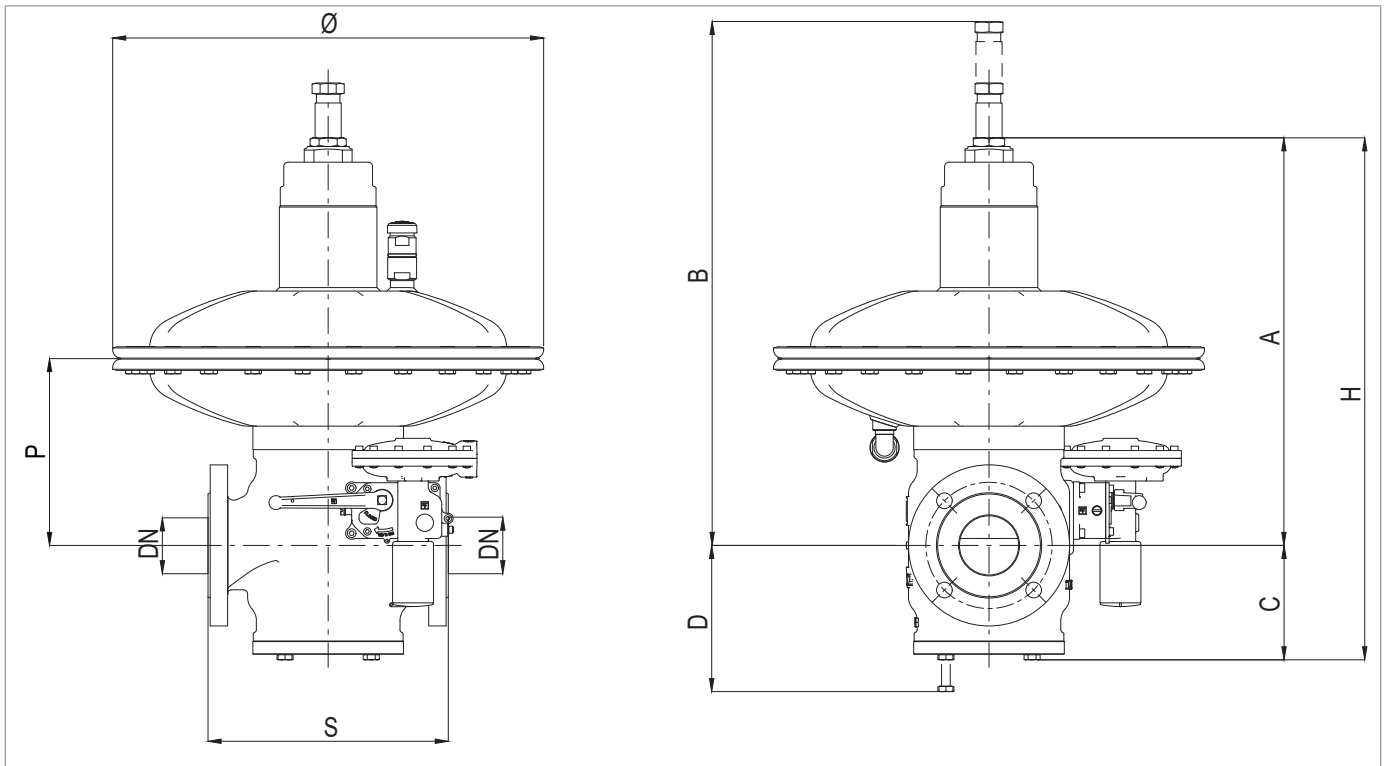

Fig. 5.10. NORVAL + SN physical characteristics

NORVAL overall dimensions								
Nominal diameter [mm]	25	40	50	65	80	100	150	200
Size [inches]	1"	1" 1/2	2"	2" 1/2	3"	4"	6"	8"
S - Class 150	183	223	254	277	298	532	451	543
A with Ø 375TR	425	445	445	465	465	565	-	-
A with Ø 375	415	435	435	455	455	555	-	-
A with Ø 495	460	475	475	500	500	600	670	770
A with Ø 630	-	-	-	540	540	640	675	775
A with Ø 658	-	-	-	-	-	-	720	820
A with Ø 817	-	-	-	-	-	-	760	860
B with Ø 375TR	595	615	615	635	635	735	-	-
B with Ø 375	585	605	605	625	625	725	-	-
B with Ø 495	630	645	645	670	670	770	840	940
B with Ø 630	-	-	-	710	710	810	845	845
B with Ø 658	-	-	-	-	-	-	890	990
B with Ø 817	-	-	-	-	-	-	930	1030
C	100	120	120	140	140	180	220	230
D	140	160	160	180	180	220	260	300
H with Ø 375TR	525	565	575	605	505	745	-	-
H with Ø 375	515	555	555	595	595	735	-	-
H with Ø 495	560	595	595	640	640	780	890	1200
H with Ø 630	-	-	-	680	680	820	895	1105
H with Ø 658	-	-	-	-	-	-	940	1250
H with Ø 817	-	-	-	-	-	-	980	1290
P with Ø 375TR	155	170	170	195	195	280	-	-
P with Ø 375	150	165	165	190	190	275	-	-
P with Ø 495	175	190	190	210	210	300	375	475
P with Ø 630	-	-	-	220	220	310	380	480
P with Ø 658	-	-	-	-	-	-	380	480
P with Ø 817	-	-	-	-	-	-	400	500
Connecting pneumatic pipes	<ul style="list-style-type: none"> Recommended standard for control heads: Øe 14mm x Øi 12mm Recommended standard for SN pressure switch and ER device: Øe 10mm x Øi 8mm 							

Tab. 5.30.

Weight [kgf]								
Class 150	48	53	55	82	97	126	211	296

Tab. 5.31.

5.2.4 - NORVAL + ER + SN

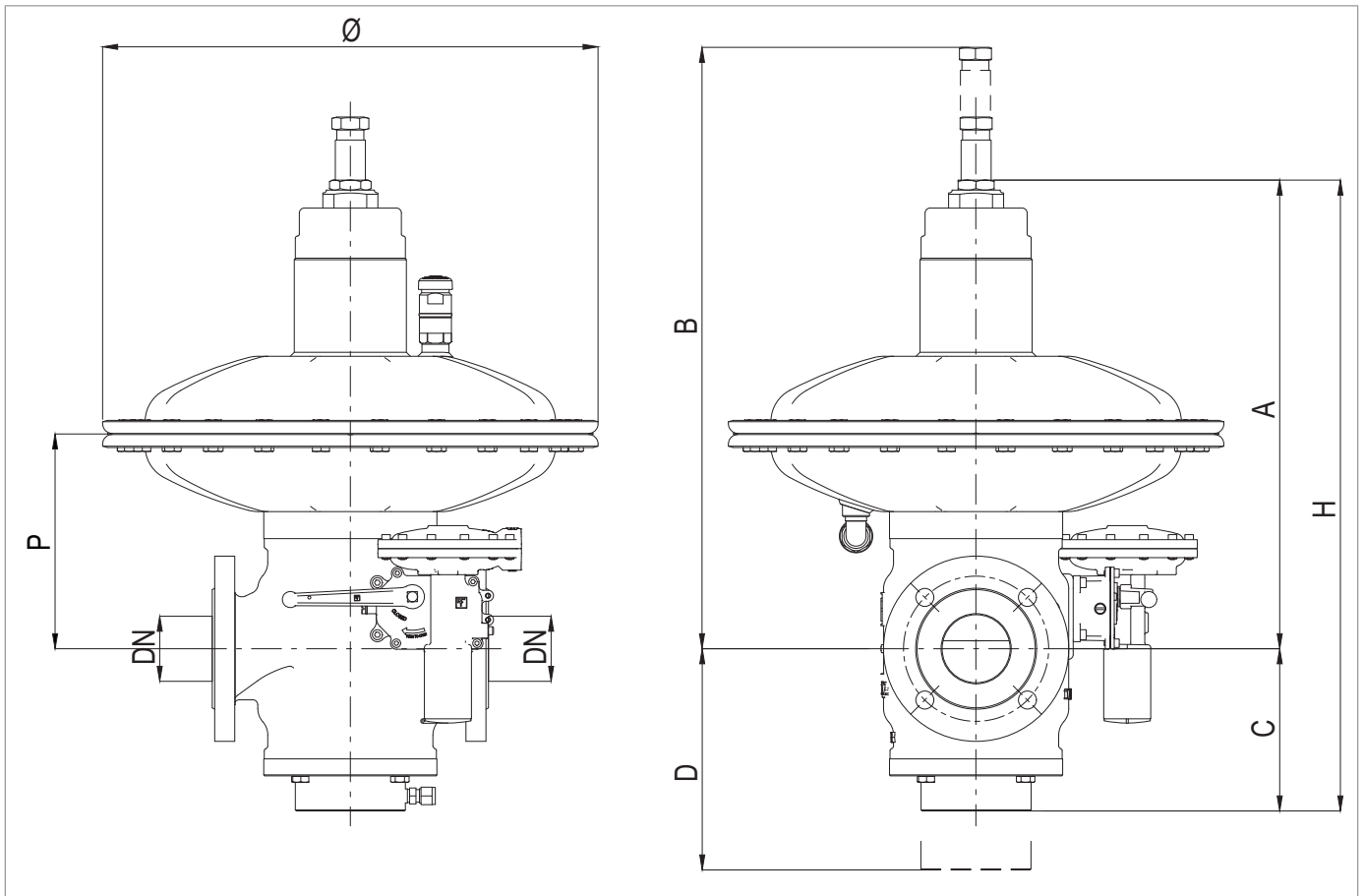

Fig. 5.11. NORVAL + ER + SN physical characteristics

NORVAL overall dimensions								
Nominal diameter [mm]	25	40	50	65	80	100	150	200
Size [inches]	1"	1" 1/2	2"	2" 1/2	3"	4"	6"	8"
S - Class 150	183	223	254	277	298	532	451	543
A with Ø 375TR	425	445	445	465	465	565	-	-
A with Ø 375	415	435	435	455	455	555	-	-
A with Ø 495	460	475	475	500	500	600	670	770
A with Ø 630	-	-	-	540	540	640	675	775
A with Ø 658	-	-	-	-	-	-	720	820
A with Ø 817	-	-	-	-	-	-	760	860
B with Ø 375TR	595	615	615	635	635	735	-	-
B with Ø 375	585	605	605	625	625	725	-	-
B with Ø 495	630	645	645	670	670	770	840	940
B with Ø 630	-	-	-	710	710	810	845	845
B with Ø 658	-	-	-	-	-	-	890	990
B with Ø 817	-	-	-	-	-	-	930	1030
C	100	120	120	140	140	180	220	230
D	140	160	160	180	180	220	260	300
H with Ø 375TR	525	565	575	605	505	745	-	-
H with Ø 375	515	555	555	595	595	735	-	-
H with Ø 495	560	595	595	640	640	780	890	1200
H with Ø 630	-	-	-	680	680	820	895	1105
H with Ø 658	-	-	-	-	-	-	940	1250
H with Ø 817	-	-	-	-	-	-	980	1290
P with Ø 375TR	155	170	170	195	195	280	-	-
P with Ø 375	150	165	165	190	190	275	-	-
P with Ø 495	175	190	190	210	210	300	375	475
P with Ø 630	-	-	-	220	220	310	380	480
P with Ø 658	-	-	-	-	-	-	380	480
P with Ø 817	-	-	-	-	-	-	400	500
Connecting pneumatic pipes	<ul style="list-style-type: none"> Recommended standard for control heads: Øe 14mm x Øi 12mm Recommended standard for SN pressure switch and ER device: Øe 10mm x Øi 8mm 							

Tab. 5.32.

Weight [kgf]								
Class 150	53	60	63	90	105	134	221	307

Tab. 5.33.

5.3 - EQUIPMENT ANCHORING AND LIFTING METHOD

 **HAZARD!**

Before moving the equipment, make sure that the capacity of the lifting equipment is suitable for the load.

 **WARNING!**

Unloading, transport and handling activities must be carried out by operators qualified and specially trained:

- on accident prevention rules;
- on maximum safety in the workplace;
- on the use of lifting equipment.

 **ATTENTION!**

Before moving the equipment:

- remove any movable or hanging component or firmly secure it to the load;
- protect fragile equipment;
- check that the load is stable.

5.3.1 - FORKLIFT HANDLING METHOD

HAZARD!

It is forbidden to:

- Do not transit under suspended loads;
- Do not move the load over the personnel operating in the site/plant area.

WARNING!





The following is not allowed on forklifts:

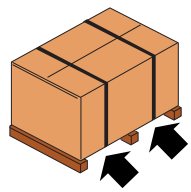

- carrying passengers;
- lifting people.

NOTICE!

Packaging must always be handled in a vertical position

Proceed as follows:

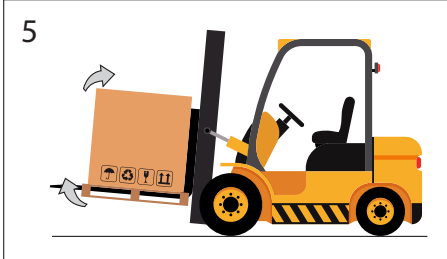
Step	Action	Image
1	Place the forks of the forklift under the load surface.	<p>1</p> 
2	Make sure that the forks extend from the front of the load (by at least 5 cm), far enough to eliminate any risk of the transported load from tipping.	<p>2</p> 
3	<p>Raise the forks until they are touching the load.</p> <div style="border: 1px solid blue; padding: 5px; margin-top: 10px;"> <p>NOTICE! Fasten the load to the forks with clamps or similar devices if required.</p> </div>	<p>3</p> 
4	Slowly lift the load by a few dozen centimetres and check its stability, making sure that the centre of gravity of the load is positioned at the centre of the lifting forks.	<p>4</p> 

Step	Action	Image
5	Tilt the mast backwards (towards the driver's seat) to help the over-turning moment and to ensure greater load stability during transport.	
6	Adjust transport speed according to the type of floor and load, avoiding sudden manoeuvres. <div style="background-color: #f4a460; padding: 5px; margin: 5px 0;">  WARNING! </div> If: <ul style="list-style-type: none"> • obstacles along the path; • particular operating situations; do not allow the operator a perfect view, the assistance of a ground operator is required, placed outside the range of action of the lifting means, with the task of signalling.	-
7	Place the load in the chosen installation area.	-

Tab. 5.34.

5.3.2 - CRANE HANDLING METHOD

⚠ WARNING!

It is mandatory to use CE marked chains, ropes and eyebolts or marked with conformity brands/marks in accordance with the regulations in force in the place of installation. Do not use chains connected to each other by bolts.

Always check that:

- the safety catch of the hook returns to the initial position;
- the ropes are in excellent condition and have an adequate section.

It is forbidden to:

- drag the load on the ground;
- operate near power lines;
- stand within the range of action of the crane.

! NOTICE!

Packaging must be always handled in a vertical position.

The equipment must be handled using the lifting points provided on the equipment itself. To carry out the transport correctly, follow the procedure below:

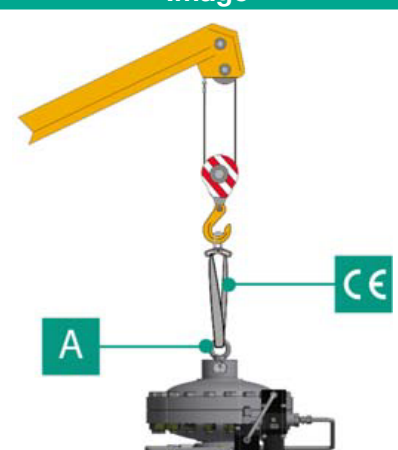
Step	Action	Image
1	Attach the lifting rope or chain to the appropriate supports. ⚠ WARNING! The lifting point is sized for lifting only the equipment, and not other parts of the system connected to it.	
2	Slightly lift the load making sure the ropes or chains are secure. ! NOTICE! Check whether the load is properly balanced.	
3	Handle the load avoiding sudden movements.	
4	Place the load in the chosen installation area.	

Tab. 5.35.

5.4 - PACKAGING REMOVAL

Packaging removal	
Operator qualification	<ul style="list-style-type: none"> Person in charge of transport, handling, unloading and placing on site; Installer.
PPE required	 <p>WARNING!</p> <p>The PPE listed in this table is related to the risk associated with the equipment. For the PPE necessary to protect against risks associated with the workplace or operating conditions, please refer to:</p> <ul style="list-style-type: none"> the regulations in force in the country of installation; any information provided by the Safety Manager at the installation facility.

Tab. 5.36.

To unpack the equipment in a cardboard box, proceed as follows:

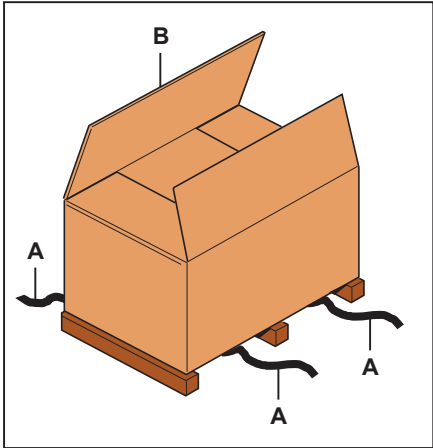
Step	Action	Image
1	Remove the straps (A).	
2	Remove the packaging cardboard (B).	
3	Remove the fasteners that secure the equipment to the base (if any).	
4	Move the equipment from the base to the place intended for it. <div style="border: 1px solid blue; padding: 5px; margin-top: 10px;"> <p>NOTICE!</p> <p>Have at least 2 operators manually move the equipment, if required due to its dimensions/weight.</p> </div>	

Tab. 5.37.

NOTICE!

After removing all packaging materials, check for any anomalies.

If there are anomalies:

- do not install the equipment;
- contact PIETRO FIORENTINI S.p.A. and specify the details provided on the equipment nameplate.

5.4.1 - PACKAGING DISPOSAL

NOTICE!

Sort the various materials making up the packaging and dispose of them in compliance with the regulations in force in the country of installation.

5.5 - STORAGE AND ENVIRONMENTAL CONDITIONS

If the equipment needs to be stored for an extended period, the minimum environmental conditions for the intended storage are provided. Only by complying with these requirements can the declared performance be guaranteed:

Conditions	Data
Maximum storage period	Maximum 3 years. <div style="border: 1px solid blue; padding: 5px;">  NOTICE! For installations in later periods, see paragraph “pre-installation warnings after prolonged storage.” </div>
Temperature	Not above 40°C
Humidity	Not above 70%
Radiation	Away from radiation sources according to UNI ISO 2230:2009

Tab. 5.38.

5.5.1 - PRE-INSTALLATION WARNINGS AFTER PROLONGED STORAGE

For installations that have been stored for longer than 3 years, the condition of all rubber parts must be checked and, if found to be damaged, they must be replaced in order to ensure the correct functioning of the equipment.

To replace the rubber parts of the equipment, please refer to chapter 9 “Maintenance and functional checks”.

<div style="border: 1px solid blue; padding: 5px;">  NOTICE! PIETRO FIORENTINI S.p.A. recommends checking the condition of rubber parts in case of downtime or storage of more than 3 years. </div>

6 - INSTALLATION

6.1 - INSTALLATION PRE-REQUISITES

6.1.1 - ALLOWED ENVIRONMENTAL CONDITIONS

WARNING!

To safely use the equipment, observe the environmental conditions allowed and the data provided on the nameplate of the regulator and any accessories (refer to paragraph 2.8 “Nameplates applied”).

The installation site must be suitable for the safe use of the equipment.

The installation area of the equipment must be properly lit to ensure that the operator has good view when working on the equipment.

NOTICE!

The equipment must operate in places that are properly lit by artificial lighting that is suitable for the protection of the operator (in compliance with UNI EN 12464-1:2011 and UNI EN 12464-2:2014). If maintenance work is to be performed in areas and/or parts that are poorly lit, it is mandatory to:

- use all the light sources of the installation plant;
- be equipped with a portable lighting system or connected to the power mains, compliant with Directive 2014/34/EU (ATEX) for use in environments at risk of explosion.

6.1.2 - CHECKS BEFORE INSTALLATION

The equipment does not require any further safety device upstream to be protected against any overpressure with respect to its **PS admissible pressure** when, for the upstream reduction station, the maximum incidental downstream pressure is:

$$\text{MIPd} \leq 1.1 \text{ PS}$$

MIPd = Maximum incidental downstream pressure value (for further information, see UNI EN 12186:2014).

ATTENTION!



If the installation of the equipment requires the field application of compression fittings, these must be installed in accordance with the instructions of the Manufacturer of the fittings themselves.

The choice of fittings must be compatible with:

- **the use specified for the equipment;**
- **the plant specifications when required.**

Before installation, it must be ensured that:

- the expected dimensions of the installation site are compatible with those of the equipment;
- there are no impediments for the workers in charge to perform maintenance;
- the upstream and downstream pipes are at the same level and can bear the weight of the equipment;
- the inlet and outlet connections of the pipes are aligned on the flanges;
- the inlet and outlet connections of the equipment are clean and have not been damaged;
- the inside of the upstream pipe is clean and free of processing residues such as welding slag, sand, paint residues, water, etc...

Installation	
Operator qualification	Installer
PPE required	<div style="text-align: center;">  </div> <div style="background-color: #ff8c00; padding: 5px; margin-top: 5px;">  WARNING! </div> <p>The PPE listed in this table is related to the risk associated with the equipment. For the PPE required to protect against risks associated with the workplace, installation or operating conditions, please refer to:</p> <ul style="list-style-type: none"> • the regulations in force in the country of installation; • any information provided by the Safety Manager at the installation facility.
Equipment required	Refer to chapter 7 "Equipment for commissioning/maintenance".

Tab. 6.39.

6.2 - SPECIFIC SAFETY INSTRUCTIONS FOR THE INSTALLATION STEP

 **WARNING!**

Before proceeding with installation, make sure that the upstream and downstream valves installed on the line are closed.

 **WARNING!**

Installation may also take place in areas where there is a risk of explosion, and this implies that all necessary prevention and protection measures must be taken.

For these measures, please refer to the regulations in force at the place of installation.

6.3 - GENERAL INFORMATION ON CONNECTIONS

The equipment must be installed in the line with the arrow on the body pointing in the gas flow direction.
The online installation must include:

Pos.	Description
1	1 shut-off valve upstream of the equipment.
2	2 vent valves located one upstream and one downstream of the equipment.
3	2 pressure gauges one upstream and one downstream of the equipment.
4	1 pressure regulator .
5	1 shut-off valve downstream of the equipment.

Tab. 6.40.

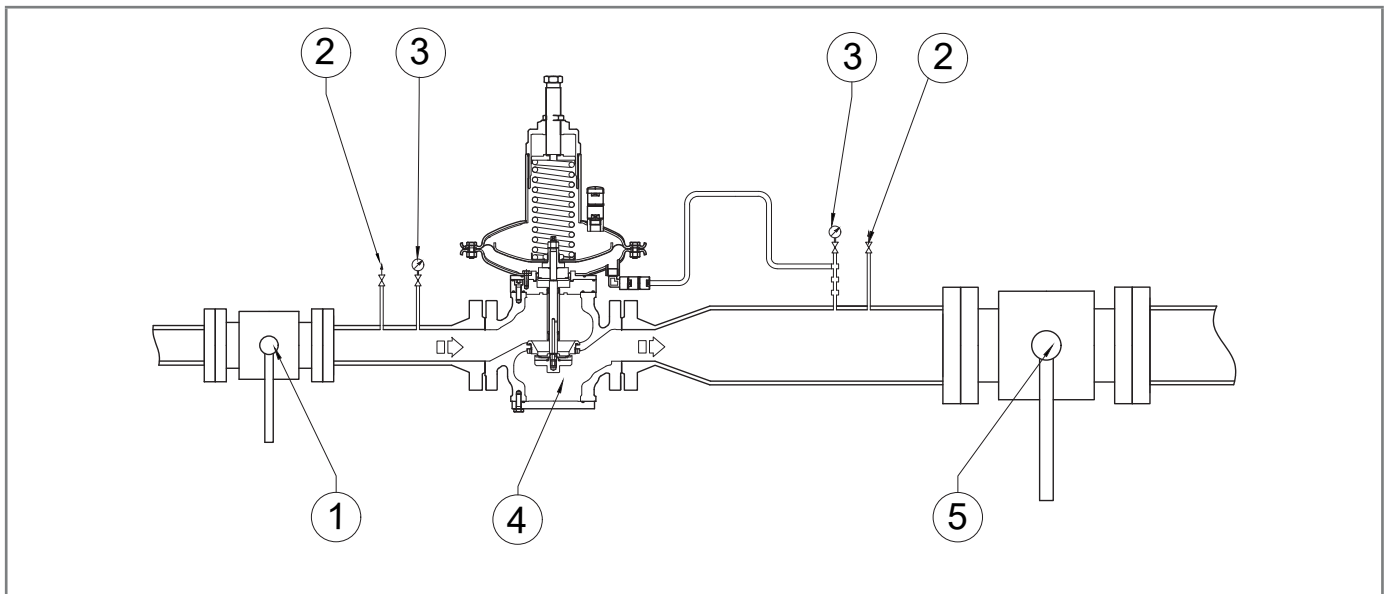

Fig. 6.12. In-line installation

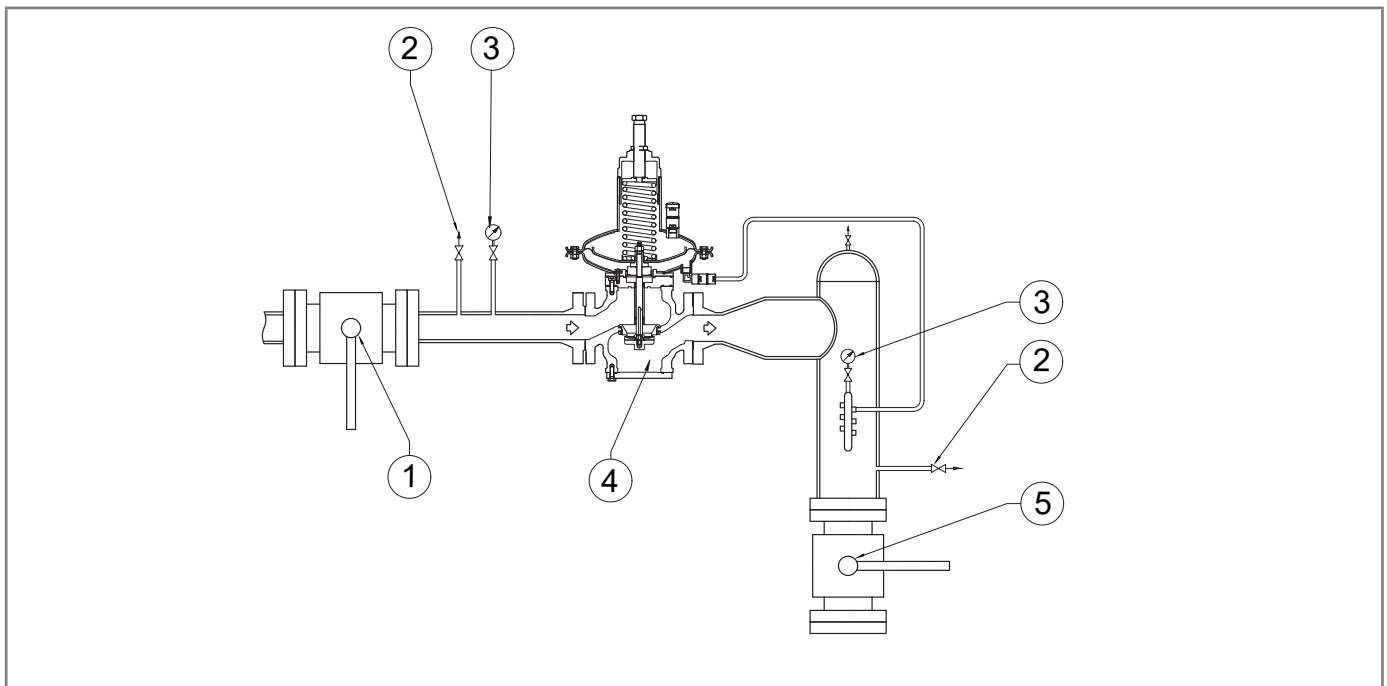

Fig. 6.13. Angle installation

! NOTICE!

When used in gas pressure reduction stations, the device must be installed at least according to the requirements of standards UNI EN 12186:2014 or UNI EN 12279:2007.

Equipment vents must be ducted in accordance with UNI EN 12186:2014 or UNI EN 12279:2007 or the standards in force at the place of installation of the equipment.

6.4 - REGULATOR INSTALLATION POSITIONS

Figures 6.14 and 6.15 depict the typical regulator arrangements:

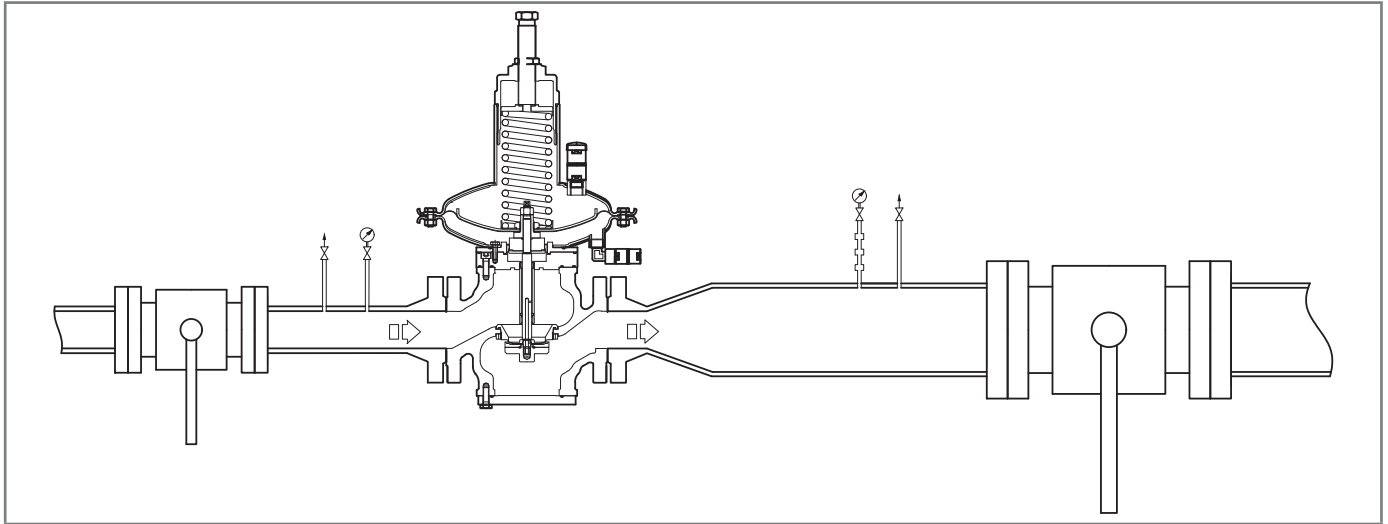

Fig. 6.14. Standard position

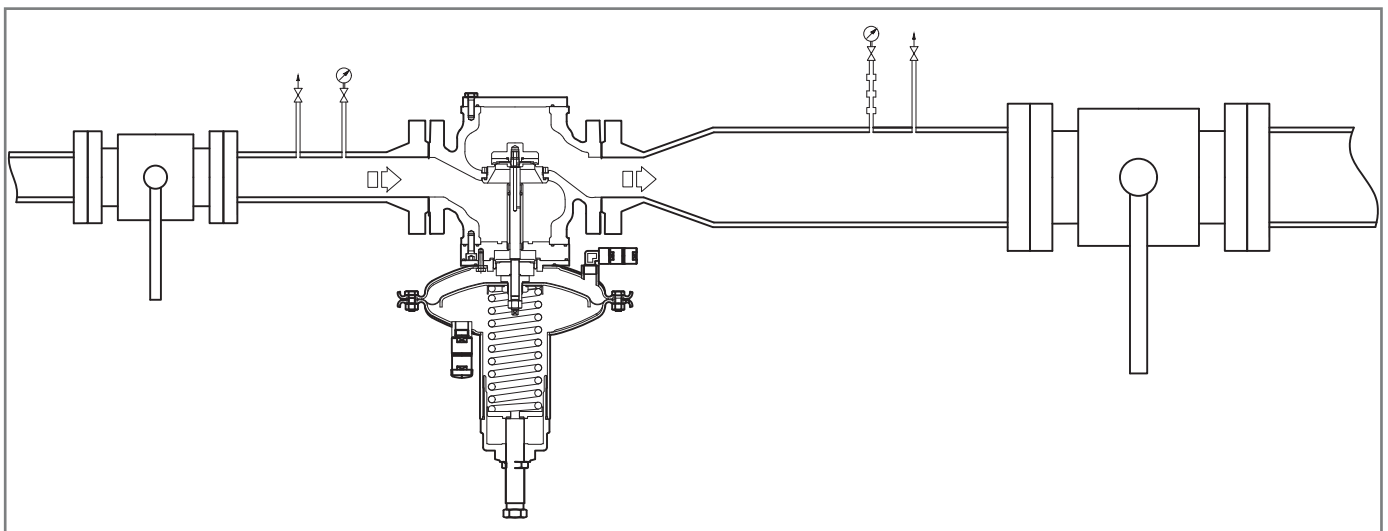

Fig. 6.15. Inverted position

6.5 - INSTALLATION PROCEDURES

6.5.1 - EQUIPMENT INSTALLATION PROCEDURE

Step	Action
1	Place the equipment in the section of the line designated for it.
2	Place the gaskets between the line flanges and the regulator flanges.
3	Insert the bolts into the appropriate holes of the connecting flanges.
4	Screw the bolts following the technical rules for tightening flanges.

Tab. 6.41.

NOTICE!

Replace the gaskets when installed after maintenance.

6.5.2 - CONNECTION OF THE SENSING LINES TO THE DOWNSTREAM PIPING

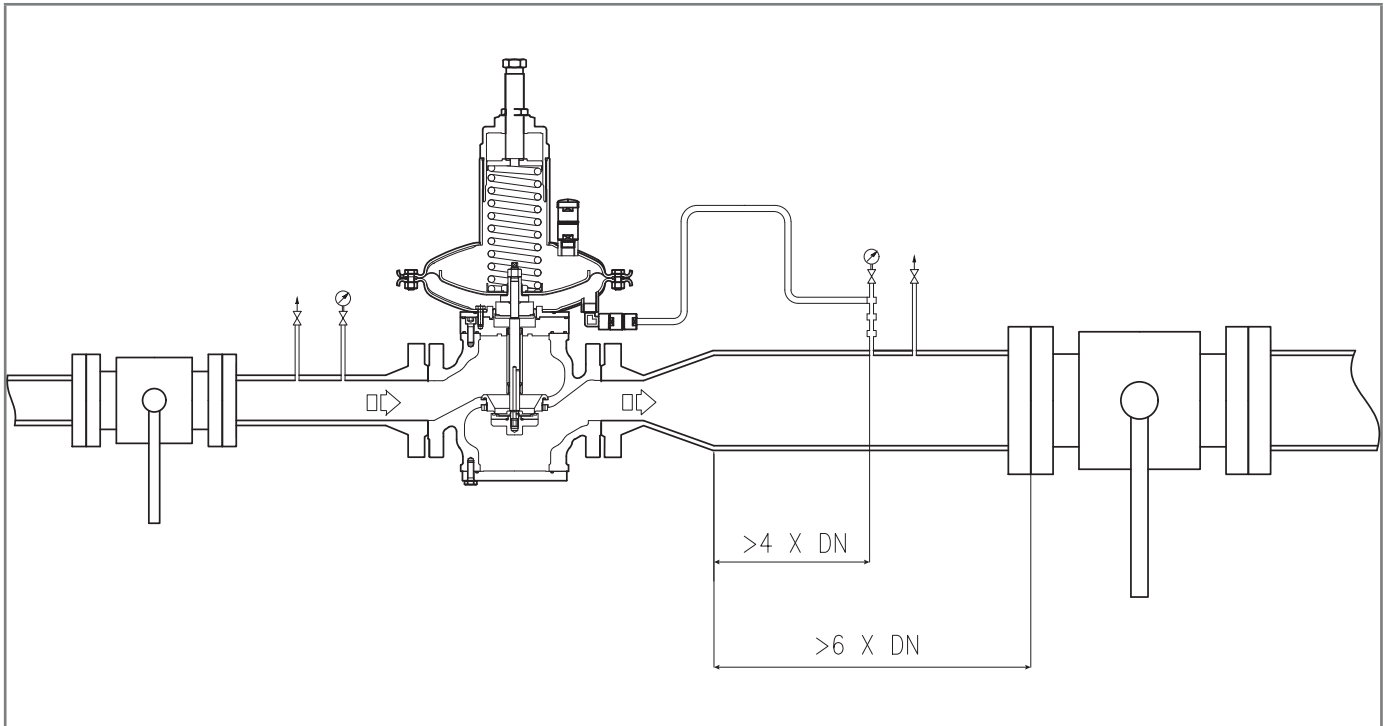

Fig. 6.16. Connection of sensing lines to the downstream piping

To obtain proper regulation, it is essential that:

- the downstream shut-off valve is placed at a distance of least 6 times the rated diameter of the pipe downstream of the regulator;
- the downstream sensing lines are placed on a straight section of pipe (with uniform diameter) having a length equal to at least 4 times the rated diameter of the pipe itself;

For optimum performance, the velocity of the pressurised fluid at the sampling point does not exceed the following values:

$V_{max} = 30 \text{ m/s}$ for $P_a > 5 \text{ bar}$

$V_{max} = 25 \text{ m/s}$ for $P_a < 5 \text{ bar}$

As a limit for use, the velocity of the fluid under pressure at the point of pick-up does not exceed the following value:

$V_{max} = 40 \text{ m/s}$ for $P_a > 5 \text{ bar}$

To calculate the flow rate, use the following formula:

$$V = 345,92 \times \frac{Q}{DN^2} \times \frac{1 - 0,002 \times Pd}{1 + Pd}$$

V = gas velocity in m/sec

Q = gas flow rate Sm³/h

DN = nominal diameter of the regulator in mm

Pd = regulator outlet pressure in barg

! NOTICE!

All on-site pneumatic connections must have pipes with a minimum inside diameter of 8 mm.

To prevent the pneumatic connections of the sensing lines from collecting impurities and condensation, it is necessary that:

- the pneumatic connection couplings are always welded on the upper part or on the horizontal axis of the piping (refer to fig. 6.17);
- the hole in the piping has no burrs or internal protrusions;
- the slope of the pneumatic connection is always 5-10% towards the downstream pipe connection.

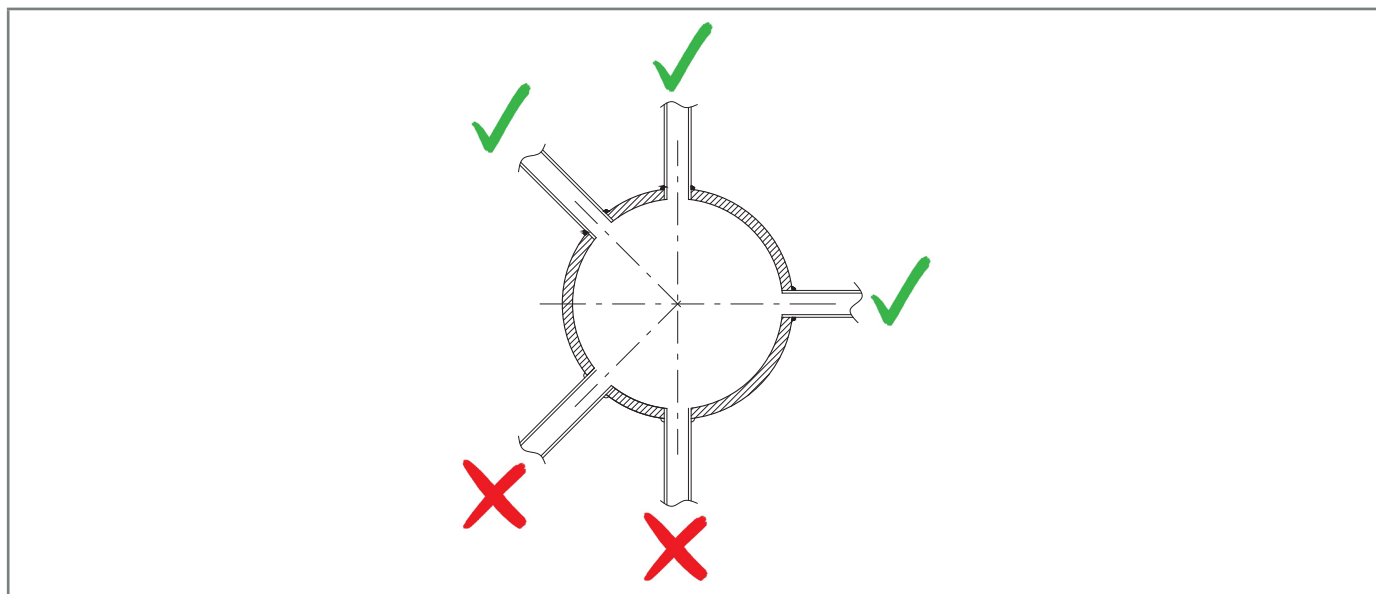

Fig. 6.17. Welded pipe connections

If there is a multiple sensing line, provide equipment connections as shown below:

- 1 to the sensing line of the control head of the main pressure regulator
- 2 to the sensing line of the control head of the main regulator with online monitor function
- 3 to the sensing line of the ER device
- 4 to the sensing line of the slam-shut valve pressure switch
- 5 and 6 free

! NOTICE!

**If there is a multiple sensing line, it is not recommended to place shut-off valves on sensing lines.
In any case, follow the regulations in force in the place of installation and use of the equipment.**

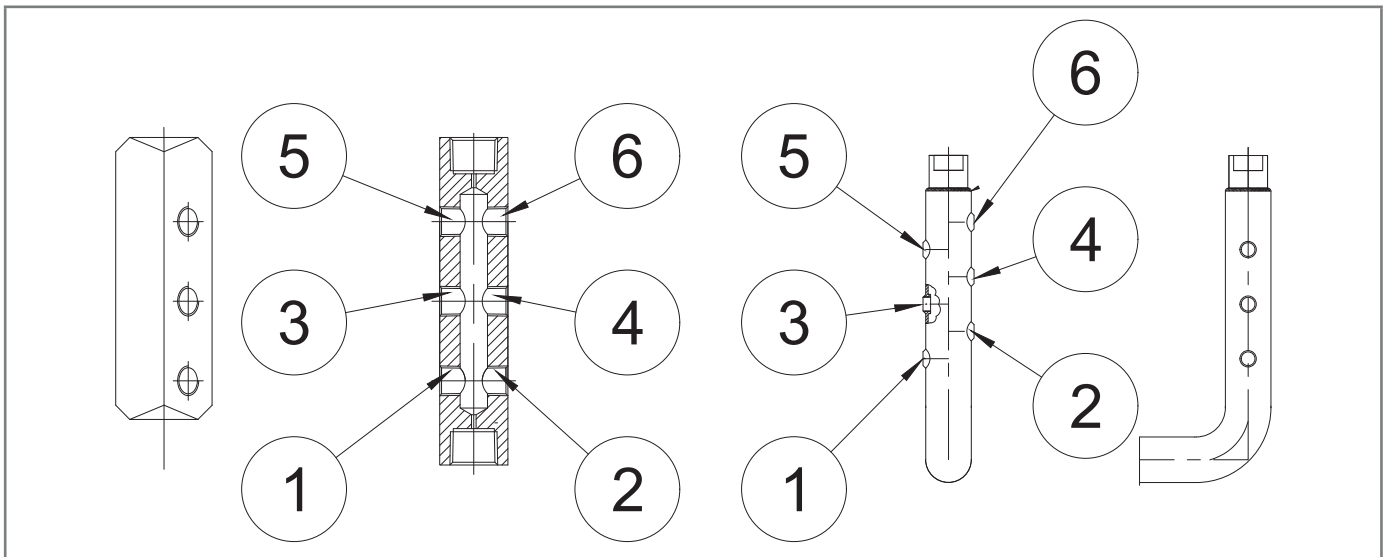

Fig. 6.18. Equipment connections

6.6 - POST-INSTALLATION AND PRE-COMMISSIONING CHECKS

When the equipment is operating, make sure that all connections are:

- properly secured/tightened to prevent any leakage during commissioning;
- connected correctly.







7 - COMMISSIONING/MAINTENANCE EQUIPMENT





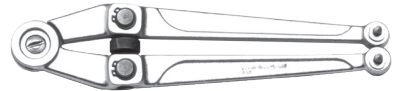

7.1 - LIST OF EQUIPMENT

Commissioning/maintenance equipment	
Operator qualification	<ul style="list-style-type: none"> • Mechanical maintenance technician; • Electrical maintenance technician; • Installer; • User's technician.
PPE required	 <p>⚠ WARNING!</p> <p>The PPE listed in this table is related to the risk associated with the equipment. For the PPE required to protect against risks associated with the workplace, installation or operating conditions, please refer to:</p> <ul style="list-style-type: none"> • the regulations in force in the country of installation; • any information provided by the Safety Manager at the installation facility.

Tab. 7.42.

The tools required for commissioning and maintenance of the equipment are described in Tab. 7.43:

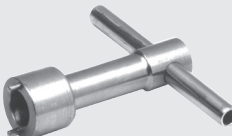
Ref.	Equipment type	Image
A	Combination wrench	
B	Adjustable wrench	
C	Roller compass wrench	
D	Double ended bi-hex tubular socket wrench	
E	Bent male hex key	
F	Male T-handle hex wrench	

Ref.	Equipment type	Image
G	T-handle hex socket wrench	
H	Phillips screwdriver	
I	Slotted screwdriver	
L	O-ring extraction tool	
M	Circlip pliers	
N	Fiorentini special key	
O	Fiorentini special key	

Tab. 7.43.

7.2 - EQUIPMENT NEEDED FOR THE DIFFERENT CONFIGURATIONS

Each table is distinguished by:

Term	Description
K.	Key, with reference to the equipment indicated in Tab. 7.43.
Code	Code, referring to the equipment.
DN	Indicates the Nominal Diameter of the reference configuration.
L.	Length, referred to the equipment.
Ref.	Reference to the equipment.
Type	Type (size) or code of the equipment.

Tab. 7.44.

Norval									
Equipment		Size [inches]							
Ref.	Type	1"	1" 1/2	2"	2" 1/2	3"	4"	6"	8"
A	K.	8-13-17-19-27-32-36	8-13-17-19-27-32-36	8-13-17-19-27-32-36	8-13-17-19-27-32-36	8-13-17-19-27-32-36	8-17-19-24-27-32-36	10-17-19-22-27-32	10-17-19-22-27-32-36
B	L.	300							
E	K.	-	-	-	-	-	4	4	4
G	K.	13-17-22	17-22	17-22	17-22	17-22	17-24-27	17-27	17-27
L	L.	7999099							
O	Code	7999045	7999047	7999047	7999049	7999049	-	-	-

Tab. 7.45.

Norval + SN									
Equipment		Size [inches]							
Ref.	Type	1"	1" 1/2	2"	2" 1/2	3"	4"	6"	8"
A	K.	8-13-17-19-24-27-32-36	8-13-17-19-24-27-32-36	8-13-17-19-24-27-32-36	8-17-19-24-27-32-36	8-17-19-24-27-32-36	8-17-19-24-27-32-36	8-10-13-17-19-22-27-32-36	8-10-13-17-19-22-27-32-36
B	L.	300							
D	K.	27	27	27	27	27	27	27	27
E	K.	4-5-8	4-5-8	4-5-8	4-5-8	4-5-8	4-5-8	4-5-8	4-5-8
G	K.	13-17-19-22	13-17-22	13-17-22	17-22	17-22	17-24-27	17-27	17-27
I	L.	65x100							
L	Code	7999099							
M	DN	19 - 60							
O	Code	7999045	7999047	7999047	7999049	7999049	-	-	-

Tab. 7.46.

Norval + SN + ER									
Equipment		Size [inches]							
Ref.	Type	1"	1" 1/2	2"	2" 1/2	3"	4"	6"	8"
A	K.	8-13-17- 19-24-27- 32-36	8-13-17- 19-24-27- 32-36	8-13-17- 19-24-27- 32-36	8-17-19- 24-27-32- 36	8-17-19- 24-27-32- 36	8-17-19- 24-27-32- 36	8-10-17- 19-22-27- 32-36	8-10-17- 19-22-27- 32-36
B	L.	300							
D	K.	10-27	10-27	10-27	10-27	10-27	10-27	10-27	10-27
E	K.	4-5-8	4-5-8	4-5-8	4-5-8	4-5-8	4-5-8	4-5-8	4-5-8
G	K.	13-17- 19-22	17-19-22	17-19-22	17-19-22	17-19-22	17-19-22	17-19-22	17-27
I	L.	65x100							
L	Code	7999099							
M	DN	19 - 60							
O	Code	7999045	7999047	7999047	7999049	7999049	-	-	-

Tab. 7.47.

8 - COMMISSIONING

8.1 - GENERAL WARNINGS

8.1.1 - SAFETY REQUIREMENTS FOR COMMISSIONING

HAZARD!

During commissioning the risks associated with any discharges to the atmosphere of flammable or noxious gases must be evaluated.

HAZARD!

In case of installation on distribution networks for natural gas, consider the risk associated with explosive mixtures (gas/air) being formed inside the piping, if the line is not subjected to inerting.

WARNING!

During commissioning, unauthorised personnel must be kept away.
The no entry area must be marked with signs and/or boundaries.

NOTICE!

Commissioning must be carried out by authorised and qualified personnel.

The equipment and the accessories present (regulator with in line monitor function with ER device, incorporated SN slam-shut valve and pressure switches) are supplied already calibrated.



NOTICE!

It is possible that for various reasons (e.g. vibrations during transport) the calibration of the equipment and of the accessories may vary, although within the values indicated on the identification plates.

Before commissioning the equipment, it is necessary to check that:

- all shut-off valves (inlet, outlet, bypass, if any) are closed;
- the gas is at a temperature within the limits specified on the data plate.

Commissioning

Operator qualification	<ul style="list-style-type: none"> • Installer; • Qualified technician.
PPE required	<div style="display: flex; align-items: center;">  </div> <div style="background-color: #f96; padding: 5px; margin-top: 5px;">  WARNING! </div> <p>The PPE listed in this table is related to the risk associated with the equipment. For the PPE required to protect against risks associated with the workplace, installation or operating conditions, please refer to:</p> <ul style="list-style-type: none"> • the regulations in force in the country of installation; • any information provided by the Safety Manager at the installation facility.
Equipment required	Refer to chapter 7 "Equipment for commissioning/maintenance".

Tab. 8.48.

8.2 - PRELIMINARY PROCEDURES FOR COMMISSIONING

HAZARD!

Before commissioning the equipment, it must be ensured that any source of formation of explosive atmosphere has been eliminated if there is such a danger.

WARNING!

Before commissioning, you need to make sure that the characteristics of the equipment are suitable for the conditions of use.

ATTENTION!

To protect the equipment from damage, the following operations must never be carried out:

- pressurisation through a valve located downstream of the equipment;
- depressurisation through a valve located upstream of the equipment.

Commissioning can be carried out using two different procedures:

Commissioning types

Injection of an inert fluid	Pressurising the equipment by injecting an inert fluid (e.g. nitrogen) to avoid potentially explosive mixtures for services with combustible gases. <div style="background-color: #f4a460; padding: 5px; margin-top: 5px;">  WARNING! During pressurisation, always check that the equipment has no leaks. </div>
Direct injection	Direct injection of gas into pipes, keeping the gas velocity in the pipes as low as possible (maximum permitted value of 5 m/s).

Tab. 8.49.

8.3 - CHECKING THE OUTER SEAL

Completely sprinkle the equipment with a foaming solution (or equivalent control system) in order to check the tightness of the regulator's external surfaces and of the connections made during installation.

8.4 - CALIBRATION OF EQUIPMENT AND OF ACCESSORIES PRESENT

 **NOTICE!**

To correctly calibrate the equipment and the accessories present, refer to the accuracy class shown on the identification plates (see paragraph 2.8).

8.5 - COMMISSIONING THE REGULATOR

In the application consisting of two pressure adjusting lines, it is advisable to commission one line at a time, starting with the line with the lowest set point.

The set point value is mentioned on the test certificate enclosed with each piece of equipment.

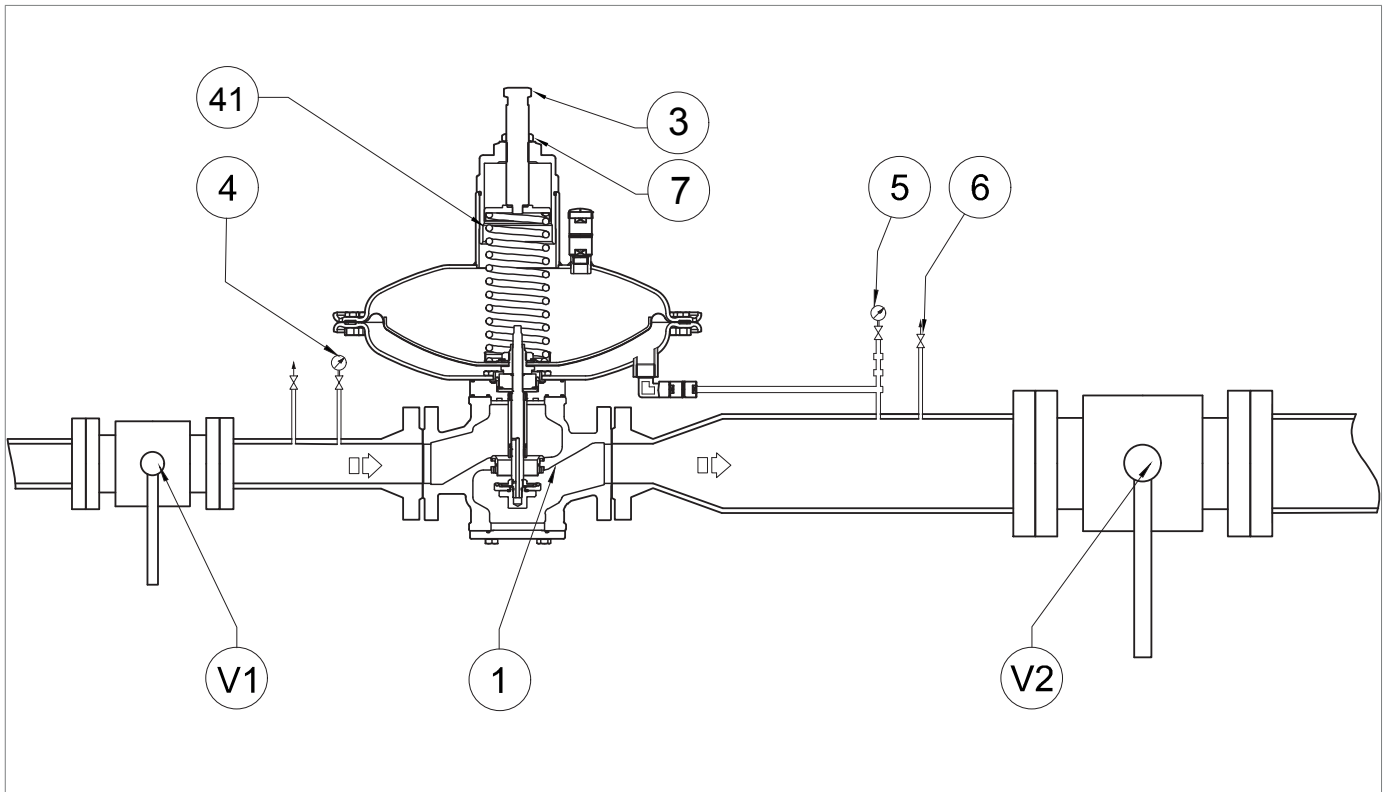

Fig. 8.19. Commissioning the NORVAL regulator

Step	Action
1	Partially open the bleed cock (6).
2	<p>Slowly open the upstream shut-off valve (V1), checking that the downstream pressure (Pd) indicated on the downstream pressure gauge (5) does not exceed the required calibration value by over 50%.</p> <div style="border: 1px solid blue; padding: 5px;"> <p>! NOTICE!</p> <p>In the first line pressurisation phase, the downstream pressure (Pd) indicated on the downstream pressure gauge (5) could exceed that required calibration value, depending on the response time of the regulator.</p> </div> <div style="border: 1px solid blue; padding: 5px;"> <p>! NOTICE!</p> <p>With regulators with calibration pressure up to 80 mbar, the response time is longer than that of regulators with calibration pressure above 80 mbar. This is due to the difference in volume of the control heads of the regulators.</p> </div>
3	When the regulator is put into service, the downstream pressure (Pd) indicated on the downstream pressure gauge (5) will be equal to the calibration value of the regulator.
4a	<p>FOR INITIAL COMMISSIONING OF THE REGULATION LINE</p> <p>If the pressure downstream (Pd) is not at the required calibration value, proceed as follows:</p> <ul style="list-style-type: none"> • downstream pressure value (Pd) lower than required calibration value: load the setting spring by turning the adjustment screw clockwise (3) • downstream pressure value (Pd) higher than required calibration value: load the setting spring by turning the adjustment screw anti-clockwise (3)
4b	<p>AFTER MAINTENANCE OF THE REGULATION LINE</p> <ul style="list-style-type: none"> • load the setting spring (41) and increase the pressure value of the main regulator (1) by turning the adjustment screw clockwise (3)
5	Check the downstream pressure (Pd) referring to the downstream pressure gauge (5).
6	Close the bleed cock (6).
7	<p>Check that the downstream pressure (Pd), after an increment phase, does not exceed the closing pressure value (refer to the SG value displayed on the plate, see par. 2.8).</p> <div style="border: 1px solid blue; padding: 5px;"> <p>! NOTICE!</p> <p>If the pressure in the pipe section between the regulator and the downstream shut-off valve (V2) exceeds the closing pressure value, consult chapter 10 “Troubleshooting” to clear the causes of the malfunctions.</p> </div>
8	<p>Check the tightness of all the fittings between the shut-off valves (V1, V2).</p> <div style="border: 1px solid blue; padding: 5px;"> <p>! NOTICE!</p> <p>Check for leaks with a foaming agent.</p> </div>
9	In case of external leaks, eliminate the leak points and repeat the procedure from step 7.
10	<p>Open downstream shut-off valve (V2) very slowly until the pipeline fills completely.</p> <div style="border: 1px solid blue; padding: 5px;"> <p>! NOTICE!</p> <p>If the pressure of the downstream pipeline is lower than the calibration pressure, shutter the opening of the downstream shut-off valve (V2) so as to not to exceed the maximum flow rate value of the installation.</p> </div>
11	Block the adjustment screw (3) with the fixing nut (7) of the regulator (1).

Tab. 8.50.

8.6 - COMMISSIONING PROCEDURE OF REGULATION LINE: NORVAL REGULATOR + NORVAL REGULATOR WITH IN LINE MONITOR FUNCTION

NOTICE!

VALID FOR REGULATORS WITH DOWNSTREAM PRESSURE UP TO 80mbar

The setting spring (41.1) of the main regulator (1) must allow you to obtain the downstream pressure value (Pd) 10-20% higher than the calibration pressure value of the regulator with in-line monitor function (2).

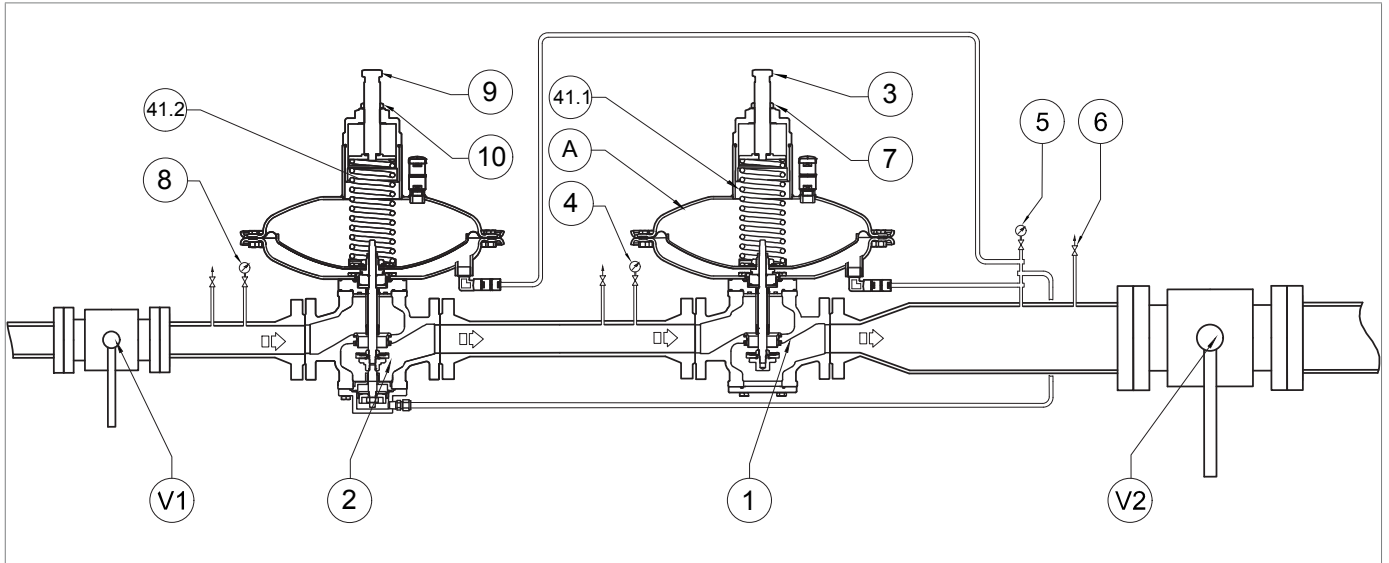
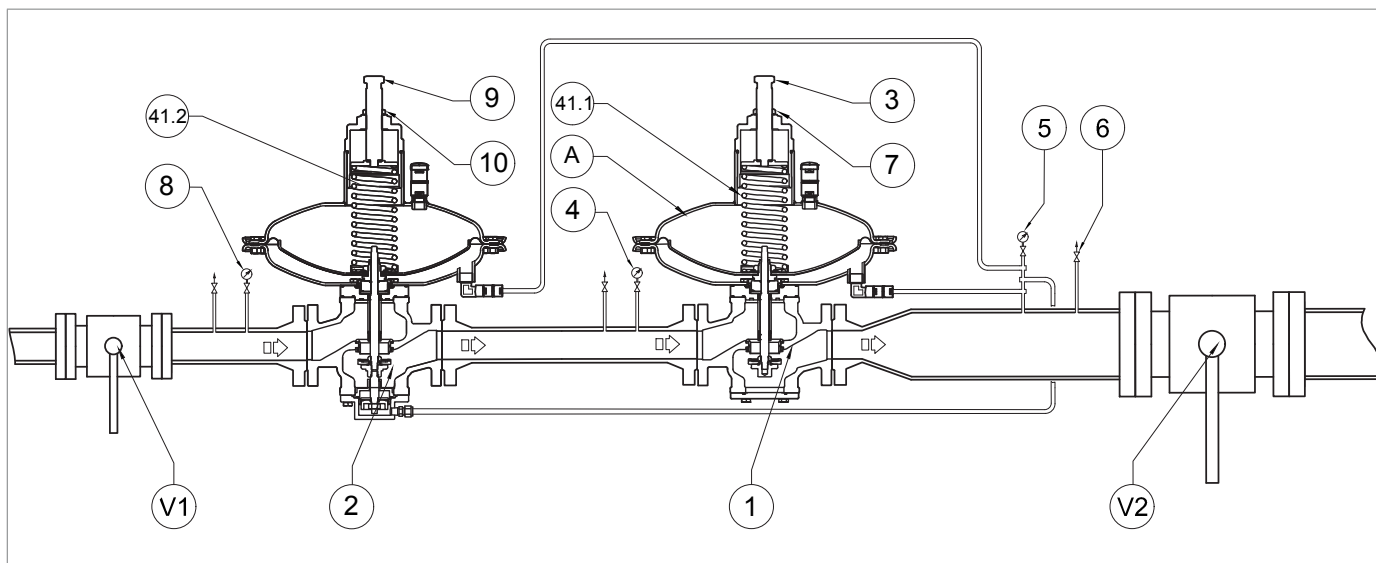

Fig. 8.20. Commissioning of NORVAL regulator + regulator with in-line monitor function

Step	Action
1	Partially open the bleed cock (6).
2	<p>Slowly open the upstream shut-off valve (V1), checking that the downstream pressure (Pd) indicated on the downstream pressure gauge (5) does not exceed the required calibration value by over 50%.</p> <div style="border: 1px solid black; padding: 5px;"> <p>! NOTICE!</p> <p>In the first line pressurisation phase, the downstream pressure (Pd) indicated on the downstream pressure gauge (5) could exceed that required calibration value, depending on the response time of the main regulator (1).</p> </div> <div style="border: 1px solid black; padding: 5px;"> <p>! NOTICE!</p> <p>With regulators with calibration pressure up to 80 mbar, the response time is longer than that of regulators with calibration pressure above 80 mbar. This is due to the difference in volume of the control heads of the regulators.</p> </div>
3	When the main regulator (1) is put into service, the downstream pressure (Pd) indicated on the downstream pressure gauge (5) will be equal to the calibration value of the main regulator (1).
4	<p>Check that the regulator with in-line monitor function (2) is fully open (100%).</p> <div style="border: 1px solid black; padding: 5px;"> <p>! NOTICE!</p> <p>The regulator with monitor function (2) is fully open, when the pressure indicated on the intermediate pressure gauge (4) is the same as the upstream pressure gauge (8).</p> </div>
5	Open the upstream shut-off valve (V1) completely.
6	<p>Increase the downstream pressure value (Pd) beyond the calibration pressure of the regulator with monitor function (2), by turning the adjustment screw (3) of the main regulator (1) clockwise.</p> <div style="border: 1px solid black; padding: 5px;"> <p>! NOTICE!</p> <p>If the setting spring of the main regulator (1) does not reach a sufficient pressure to trip the regulator with in-line monitor function (2), pressurise the chamber (A) by using an external source (see par. 8.6.1).</p> </div> <div style="border: 1px solid black; padding: 5px;"> <p>! NOTICE!</p> <p>The value of the pressure introduced by the external source can be up to 50% more than the calibration value of the regulator with in-line monitor function (2).</p> </div>
7	Check that the regulator with in-line monitor function (2) is running, checking that the pressure indicated on the intermediate pressure gauge (4) is equal to the calibration value of the regulator with in-line monitor function (2).
8a	<p>FOR INITIAL COMMISSIONING OF THE REGULATION LINE</p> <p>If the downstream pressure (Pd) is not at the required calibration value for the regulator with in-line monitor function (2), proceed as follows:</p> <ul style="list-style-type: none"> • downstream pressure value (Pd) lower than required calibration value: load the setting spring by turning the adjustment screw clockwise (9) • downstream pressure value (Pd) higher than required calibration value: load the setting spring by turning the adjustment screw anti-clockwise (9)
8b	<p>AFTER MAINTENANCE OF THE REGULATION LINE</p> <ul style="list-style-type: none"> • load the setting spring (41.2) and increase the pressure value of the regulator with monitor function (2) by turning the adjustment screw clockwise (9)



Commissioning of NORVAL regulator + regulator with in-line monitor function

Step	Action
9	<p>Check the calibration value of the regulator with in-line monitor function (2), referring to the downstream pressure gauge (5).</p> <div style="border: 1px solid blue; padding: 5px;"> <p>! NOTICE!</p> <p>If the calibration pressure is not as pre-established, repeat steps 8a (first commissioning) or 8b (after maintenance).</p> </div>
10	Slowly close the bleed cock (6).
11	<p>Check that the downstream pressure, after an increment phase, does not exceed the closing pressure value of the regulator with in-line monitor function (2) (refer to the SG value displayed on the plate, see par. 2.8).</p> <div style="border: 1px solid blue; padding: 5px;"> <p>! NOTICE!</p> <ul style="list-style-type: none"> • If the downstream pressure exceeds the closing pressure value, refer to chapter 10 “Troubleshooting” to clear the causes of the malfunctions. • Check the pressure referring to the downstream pressure gauge (5). </div>
12	Partially open the bleed cock (6).
13	Discharge the regulation spring of the main regulator (1) or disconnect the external pressure source from the chamber (A).
14	<p>Check that the regulator with in-line monitor function (2) is fully open (100%).</p> <div style="border: 1px solid blue; padding: 5px;"> <p>! NOTICE!</p> <p>The regulator with in-line monitor function (2) is fully open, when the pressure indicated on the intermediate pressure gauge (4) is the same as the upstream pressure gauge (8).</p> </div>
15	Check that the calibration pressure of the main regulator (1) is as pre-established by referring to the pressure value indicated on the downstream pressure gauge (5).
16a	<p>FOR INITIAL COMMISSIONING OF THE REGULATION LINE</p> <p>If the pressure downstream (P_d) is not at the required calibration value, proceed as follows:</p> <ul style="list-style-type: none"> • downstream pressure value (P_d) lower than required calibration value: load the setting spring by turning the adjustment screw clockwise (3) • downstream pressure value (P_d) higher than required calibration value: load the setting spring by turning the adjustment screw anti-clockwise (3)

Step	Action
	AFTER MAINTENANCE OF THE REGULATION LINE
16b	<ul style="list-style-type: none"> load the setting spring (41.1) and increase the pressure value of the main regulator (1) by turning the adjustment screw clockwise (3)
17	Slowly close the bleed cock (6).
	Check that the downstream pressure, after an increment phase, does not exceed the closing pressure value of the main regulator (1) (refer to the SG value displayed on the plate, see par. 2.8).
18	<div style="border: 1px solid blue; padding: 5px;"> <p>! NOTICE!</p> <ul style="list-style-type: none"> If the downstream pressure exceeds the closing pressure value, refer to chapter 10 “Troubleshooting” to clear the causes of the malfunctions. Check the pressure referring to the downstream pressure gauge (5). </div>
19	Using a foaming agent, check all the junctions between shut-off valves (V1, V2) for proper sealing.
20	In case of external leaks, eliminate the leak points and repeat the procedure from step 1.
	Open the downstream shut-off valve (V2) very slowly until the pipeline fills completely.
21	<div style="border: 1px solid blue; padding: 5px;"> <p>! NOTICE!</p> <ul style="list-style-type: none"> If the pressure of the downstream pipeline is lower than the calibration pressure, shutter the opening of the downstream shut-off valve (V2) so as to not to exceed the maximum flow rate value of the installation. Check the pressure referring to the downstream pressure gauge (5). </div>
22	Block the adjustment screw (9) with the fixing nut (10) of the regulator with in-line monitor function (2).
23	Block the adjustment screw (3) with the fixing nut (7) of the main regulator (1).

Tab. 8.51.

8.6.1 - PRESSURISING WITH EXTERNAL SOURCE

If the setting spring of the main regulator (1) does not reach a sufficient pressure to put into service the regulator with in-line monitor function (2), you may pressurise the chamber (A) of the control head of the main regulator (1) by using an external source.

Pressurisation can be done:

- with external lines;
- manually.

The introduced pressure is controlled by using pressure gauges or transducers.

To correctly discharge the introduced pressure, make sure there is an additional bleed cock (18).

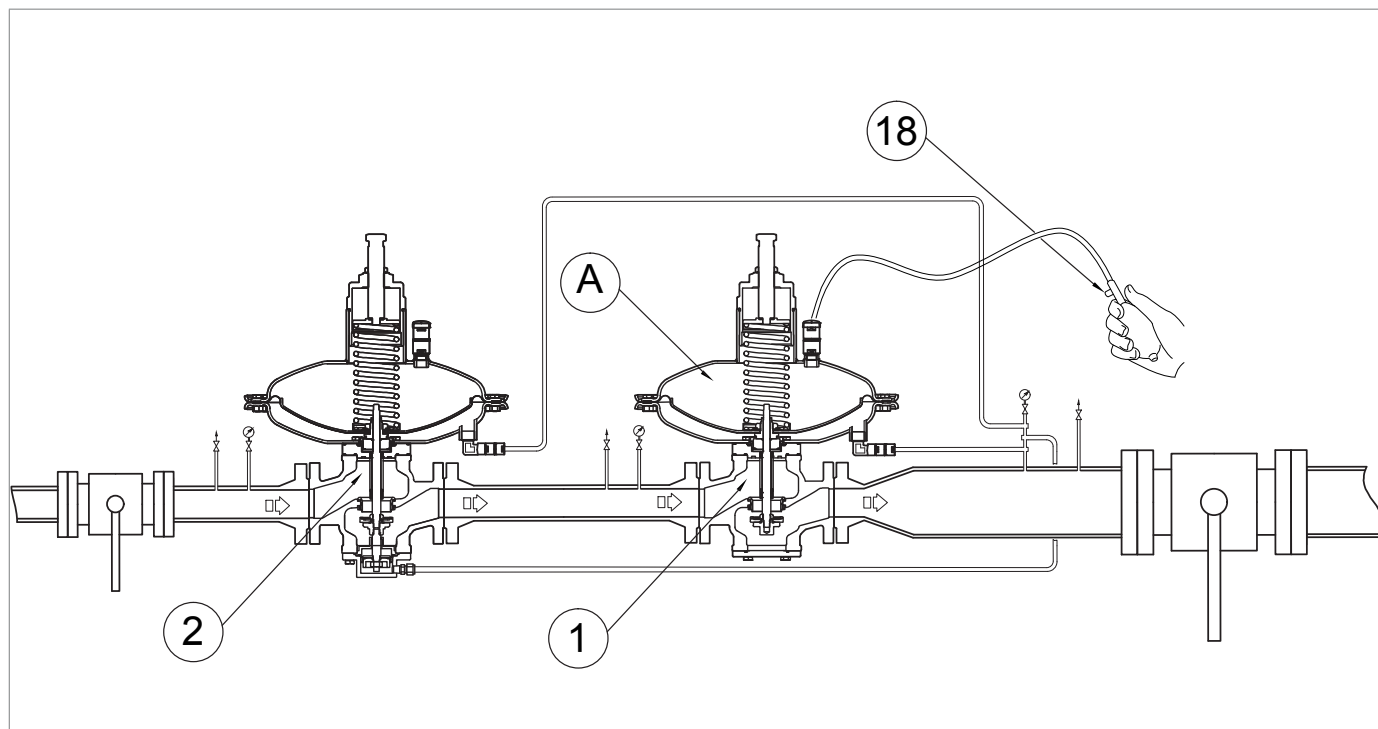

Fig. 8.21. Pressurising with external source (hand pump)

8.7 - COMMISSIONING PROCEDURE OF NORVAL REGULATOR WITH SN SLAM-SHUT VALVE

8.7.1 - INTERNAL TIGHTNESS CHECK OF SN SLAM-SHUT VALVE

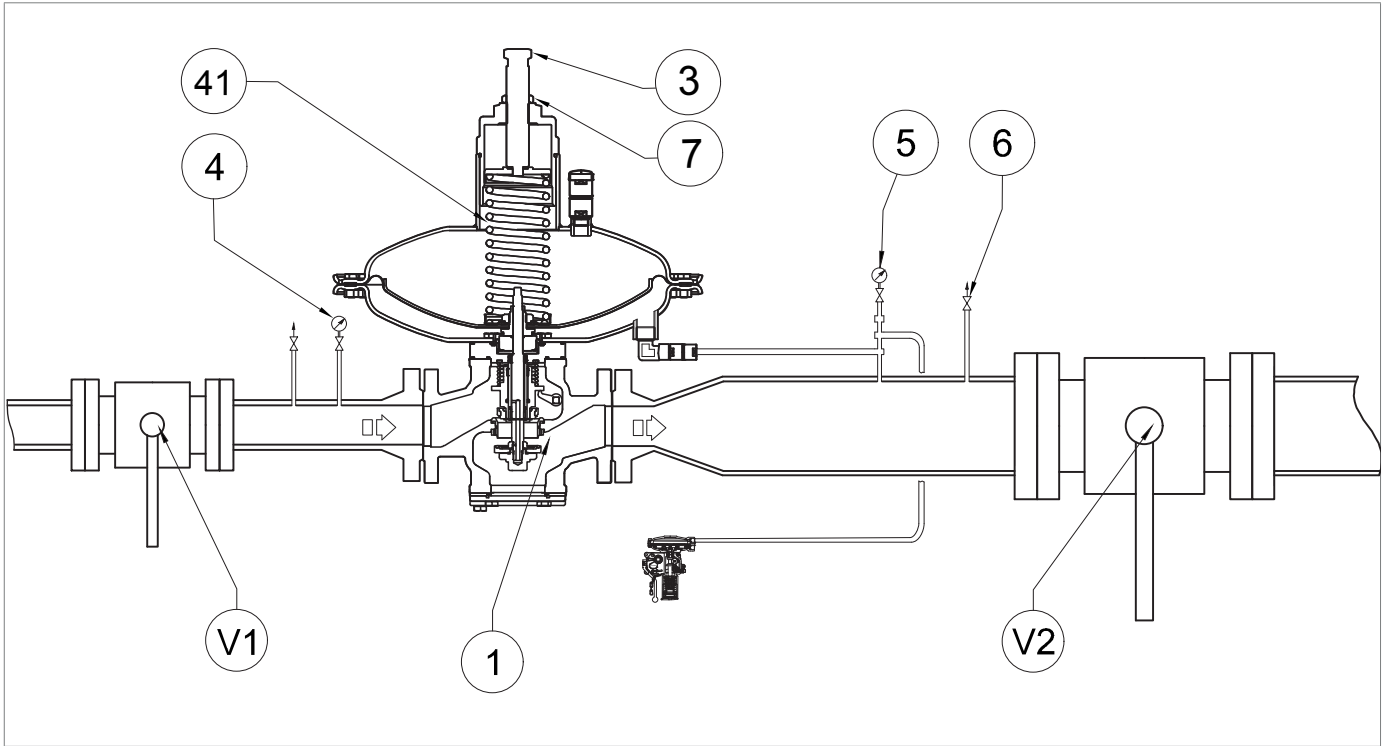

Fig. 8.22. Commissioning of NORVAL regulator with SN slam-shut valve

Step	Action
1	Check that the slam-shut valve is in the closed position.
2	Open the bleed cock (6) to fully discharge the downstream section.
3	Slowly open the upstream shut-off valve (V1).
4	Check the internal tightness of the slam-shut valve by means of the bleed cock (6). <div style="border: 1px solid black; padding: 5px; margin-top: 5px;"> <p>! NOTICE!</p> <ul style="list-style-type: none"> • Check for leaks with a foaming agent; • In case of leaks, refer to chapter 10 “Troubleshooting” to clear the causes of the malfunctions. </div>

Tab. 8.52.

8.7.2 - COMMISSIONING OF NORVAL REGULATOR WITH SN SLAM-SHUT VALVE

For the following procedure, refer to figure 8.22 in paragraph 8.7.1 “Tightness check of SN slam-shut valve”:

Step	Action
1	Make sure that the bleed cock (6) is partially open.
2	<p>Check that the SN slam-shut valve is in the closed position.</p> <p>! NOTICE!</p> <p>If the SN slam-shut valve is in the open position, close it using the manual button (fig. 8.23, ref. 10).</p>
3	Slowly open the upstream shut-off valve (V1), checking the pressure indicated by the upstream pressure gauge (4).
4	<p>Perform the internal tightness check of the SN slam-shut valve, referring to chapter 8.7.1.</p> <p>! NOTICE!</p> <p>In case of leaks, refer to chapter 10 “Troubleshooting” to clear the causes of the malfunctions.</p>
5	Slowly pressurise the regulation line, acting on the lever of the SN slam-shut valve (refer to section “Operation” in par. 4.5.4.1), checking that the downstream pressure (Pd) indicated on the downstream pressure gauge (5) does not exceed the required calibration value by over 50%.
6	<p>When the regulator is put into service, the pressure on the downstream pressure gauge (5) will be equal to the calibration value of the main regulator.</p> <p>! NOTICE!</p> <p>In the first line pressurisation phase, the pressure on the downstream pressure gauge (5) could exceed the required calibration value, depending on the response time of the regulator.</p>
7	Open the upstream shut-off valve (V1) completely.
8	Check calibrations of the pressure switch of the SN slam-shut valve by referring to paragraph 8.7.3.
9a	<p>FOR INITIAL COMMISSIONING OF THE REGULATION LINE</p> <p>If the pressure downstream (Pd) is not at the required calibration value, proceed as follows:</p> <ul style="list-style-type: none"> downstream pressure value (Pd) lower than required calibration value: load the setting spring by turning the adjustment screw clockwise (3) downstream pressure value (Pd) higher than required calibration value: load the setting spring by turning the adjustment screw anti-clockwise (3)
9b	<p>AFTER MAINTENANCE OF THE REGULATION LINE</p> <ul style="list-style-type: none"> load the setting spring (41) and increase the pressure value of the regulator (1) by turning the adjustment screw clockwise (3)
10	Check the downstream pressure (Pd) referring to the downstream pressure gauge (5).
11	Close the bleed cock (6).
12	<p>Check that the downstream pressure (Pd), after an increment phase, does not exceed the closing pressure value (refer to the SG value displayed on the plate, see par. 2.8).</p> <p>! NOTICE!</p> <p>If the pressure in the pipe section between the regulator and the downstream shut-off valve (V2) exceeds the closing pressure value, consult chapter 10 “Troubleshooting” to clear the causes of the malfunctions.</p>

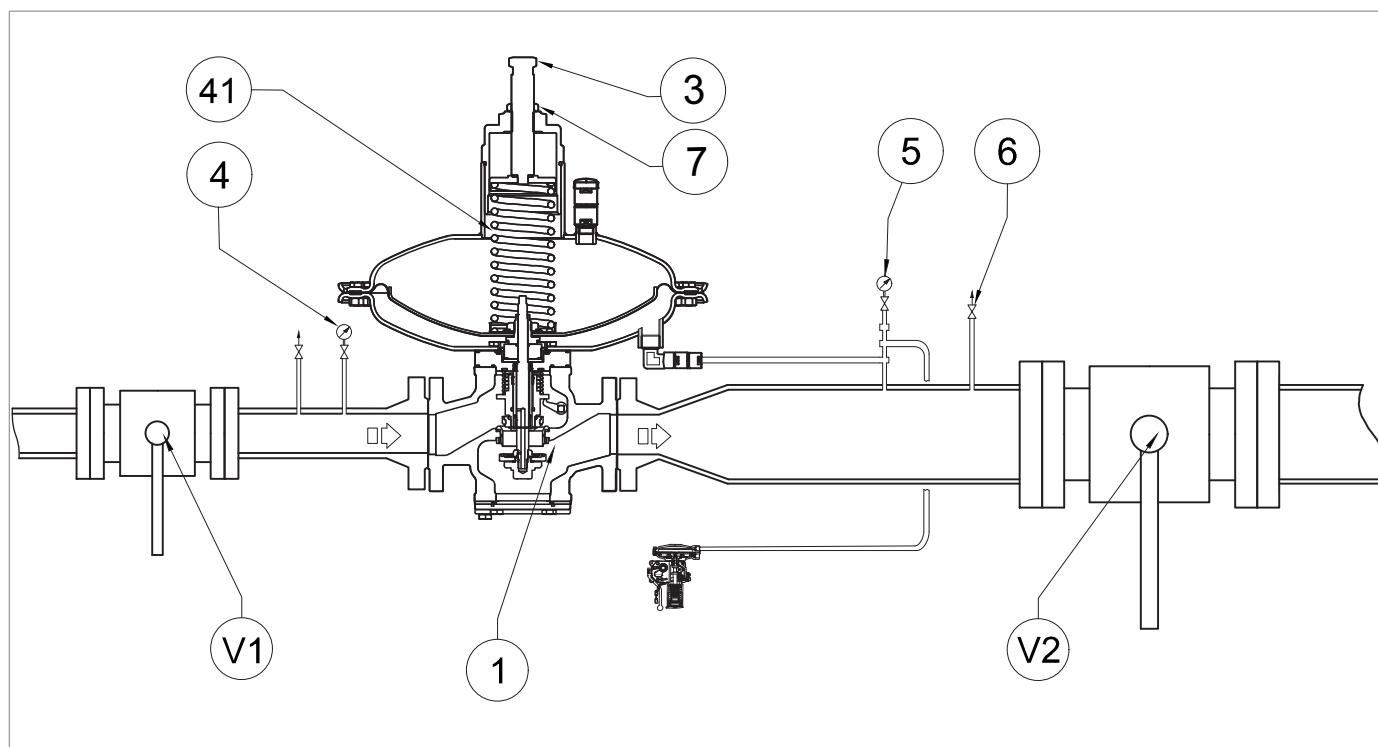

Commissioning of NORVAL regulator with SN slam-shut valve

Step	Action
13	<p>Check the tightness of all the fittings between the shut-off valves (V1, V2).</p> <p>! NOTICE!</p> <p>Check for leaks with a foaming agent.</p>
14	If external leaks are noticed, eliminate the leak points and repeat the procedure from step 7.
15	<p>Open downstream shut-off valve (V2) very slowly until the pipeline fills completely.</p> <p>! NOTICE!</p> <p>If the pressure of the downstream pipeline is lower than the calibration pressure, shutter the opening of the downstream shut-off valve (V2) so as to not to exceed the maximum flow rate value of the installation.</p>
16	Block the adjustment screw (3) with the fixing nut (7) of the regulator (1).

Tab. 8.53.

8.7.3 - CALIBRATION PROCEDURE FOR PRESSURE SWITCHES MOD. SN-91, SN-92 FOR INCORPORATED SN SLAM-SHUT VALVE

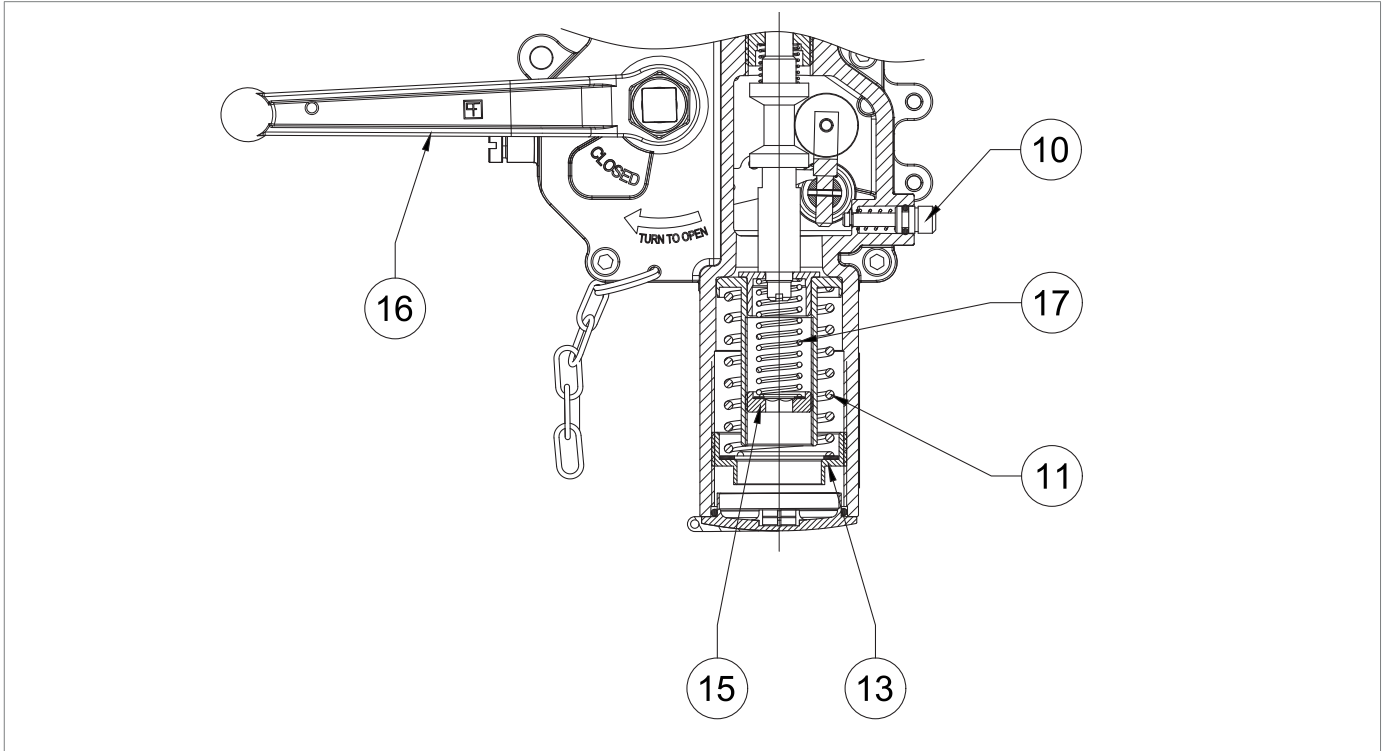

Fig. 8.23. Calibration of pressure switches mod. SN-91, SN-92

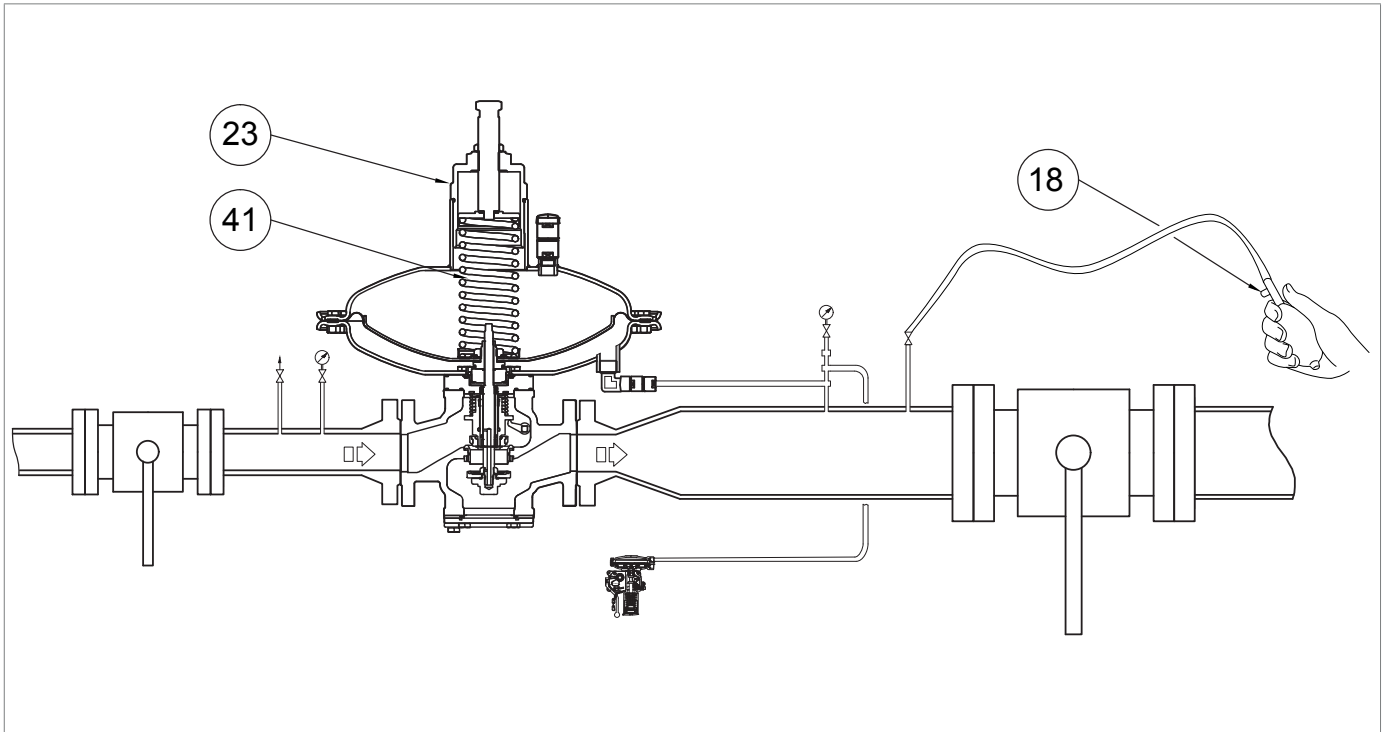



Fig. 8.24. Pressurising with external source for incorporated SN slam-shut valve

SPRING CALIBRATION FOR MAXIMUM PRESSURE TRIP

Step	Action
1	<p>Increase the downstream pressure to the tripping value of the slam-shut valve, connecting an external pressure source to the bleed cock (fig. 8.19, ref. 6) applied on the downstream pipe.</p> <div style="border: 1px solid black; padding: 5px;"> <p> NOTICE!</p> <p>Check the tripping pressure value of the slam-shut valve indicated on the downstream pressure gauge (fig. 8.19, ref. 5).</p> </div>
2	<p>If the slam-shut valve:</p> <ul style="list-style-type: none"> trips before the expected pressure value, screw in (clockwise) the adjustment ring nut (fig. 8.23, ref. 13) to further compress the spring (fig. 8.23, ref. 11); does not trip before the expected pressure value: unscrew (anticlockwise) the adjustment ring nut (fig. 8.23, ref. 13), to relieve the spring (fig. 8.23, ref. 11).
3	Decrease the pressure of the downstream section by opening the additional bleed cock (fig. 8.24, ref. 18) to bring it up to the calibration value of the regulator.
4	Close the additional bleed cock (fig. 8.24, ref. 18).
5	Open the slam-shut valve by acting on the reset lever (fig. 8.23, 16).
6	Check the maximum pressure spring for proper calibration by repeating steps 1-2-3-4 at least three times.
7	Close the bleed cock (fig. 8.19, ref. 6) and disconnect the external pressure source.

Tab. 8.54.

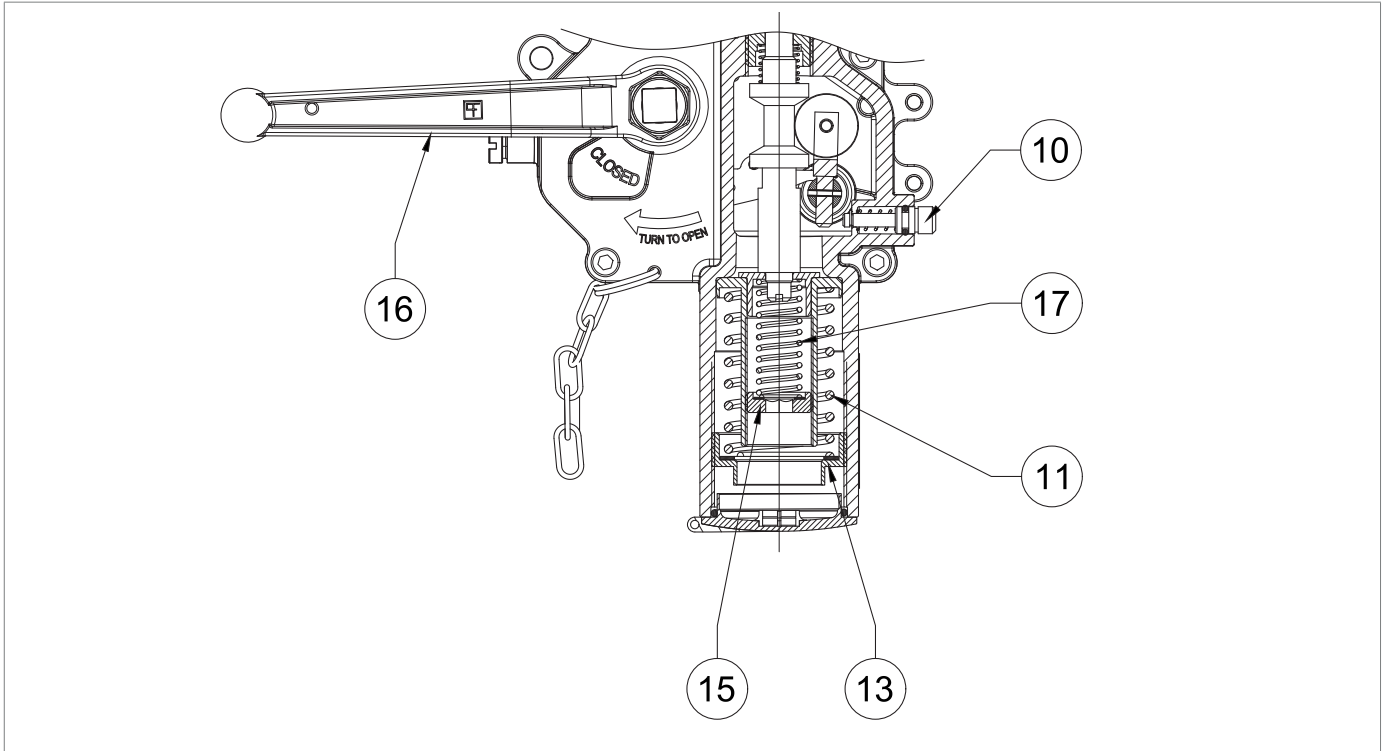

Fig. 8.23 - Calibration of pressure switches mod. SN-91, SN-92

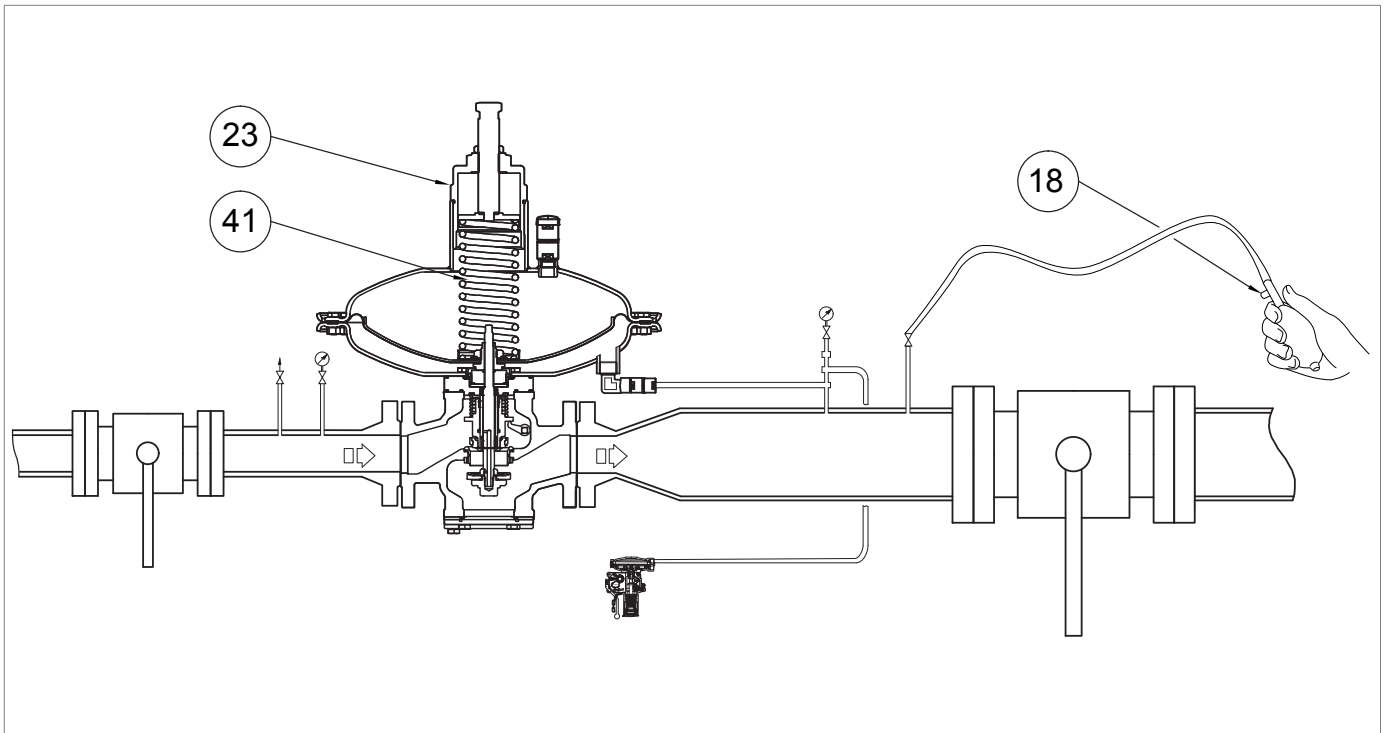

Fig. 8.24 - Pressurising with external source for incorporated SN slam-shut valve

SPRING CALIBRATION FOR MINIMUM PRESSURE TRIP (IF ANY)

Step	Action
1	Partially open the bleed cock (fig. 8.19, ref. 6) to the atmosphere and keep it open for the next steps.
2	Turn the adjustment screw (fig. 8.19, ref. 3) of the regulator anti-clockwise to decrease the downstream pressure (Pd) to the minimum pressure required for tripping of the slam-shut valve.
3	<p>If necessary, remove the closing cap (fig. 8.24, ref. 23) together with the adjustment screw and remove the regulation spring (fig. 8.24, ref. 41).</p> <div style="border: 1px solid black; padding: 5px;"> <p>! NOTICE!</p> <p>Check the tripping pressure value of the slam-shut valve indicated on the downstream pressure gauge (fig. 8.19, ref. 5).</p> </div>
4	<p>If the slam-shut valve:</p> <ul style="list-style-type: none"> trips before the expected pressure value, unscrew (anticlockwise) the adjustment ring nut (fig. 8.23, ref. 15), to relieve the spring (fig. 8.23, ref. 17); does not trip at the expected pressure value, screw in (clockwise) the adjustment ring nut (fig. 8.23, ref. 15) to further compress the spring (fig. 8.23, ref. 17).
5	<p>After having checked that the slam-shut valve trips at the preset value, proceed as follows:</p> <ol style="list-style-type: none"> Close the bleed cock (fig. 8.19, ref. 6) Position the regulation spring (fig. 8.24, ref. 41), the closing cap (fig. 8.24, ref. 23), and adjustment screw (fig. 8.19, ref. 3) Slowly open the upstream shut-off valve (V1) until the downstream pressure value (Pd) reaches the calibration value of the regulator, referring to the downstream pressure gauge (fig. 8.19, ref. 5) Close the upstream shut-off valve (V1) Slowly and partially open the bleed cock (fig. 8.19, ref. 6) to decrease the downstream pressure referring to the downstream pressure gauge (fig. 8.19, ref. 5) until it reaches the minimum pressure tripping value Check the minimum pressure spring for proper calibration by repeating steps 2-3-4 at least three times Calibrate the main regulator referring to par. 8.5
6	Open the slam-shut valve by acting on the reset lever (fig. 8.23, ref. 16) and keep it open manually.
7	Turn the adjustment screw (fig. 8.19, ref. 3) clockwise to increase the downstream pressure up to the calibration value of the regulator.
8	Set the slam-shut valve by acting on the reset lever (fig. 8.23, ref. 16).
9	Close the bleed cock (fig. 8.19, ref. 6).

Tab. 8.55.

8.8 - COMMISSIONING PROCEDURE OF REGULATION LINE: NORVAL REGULATOR + NORVAL REGULATOR WITH IN LINE MONITOR + SN SLAM-SHUT VALVE FUNCTION

! NOTICE!

VALID FOR REGULATORS WITH DOWNSTREAM PRESSURE UP TO 80mbar

The setting spring (41.1) of the main regulator (1) must allow you to obtain the downstream pressure value (Pd) 10-20% higher than the calibration pressure value of the regulator with in-line monitor function (2).

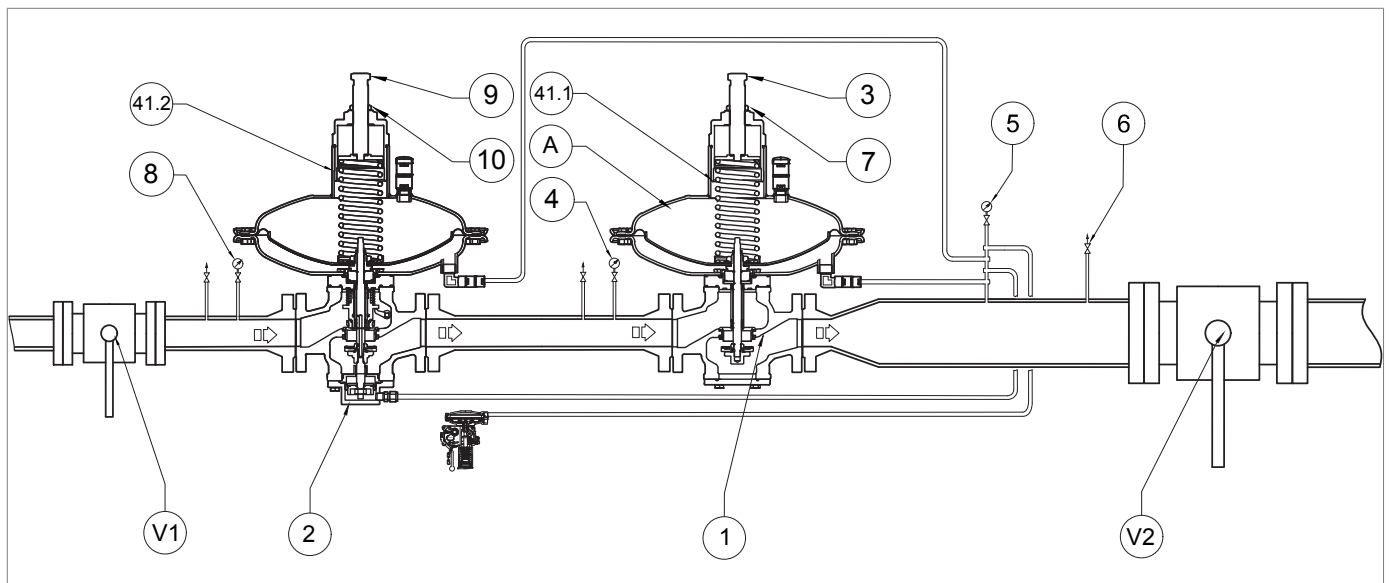
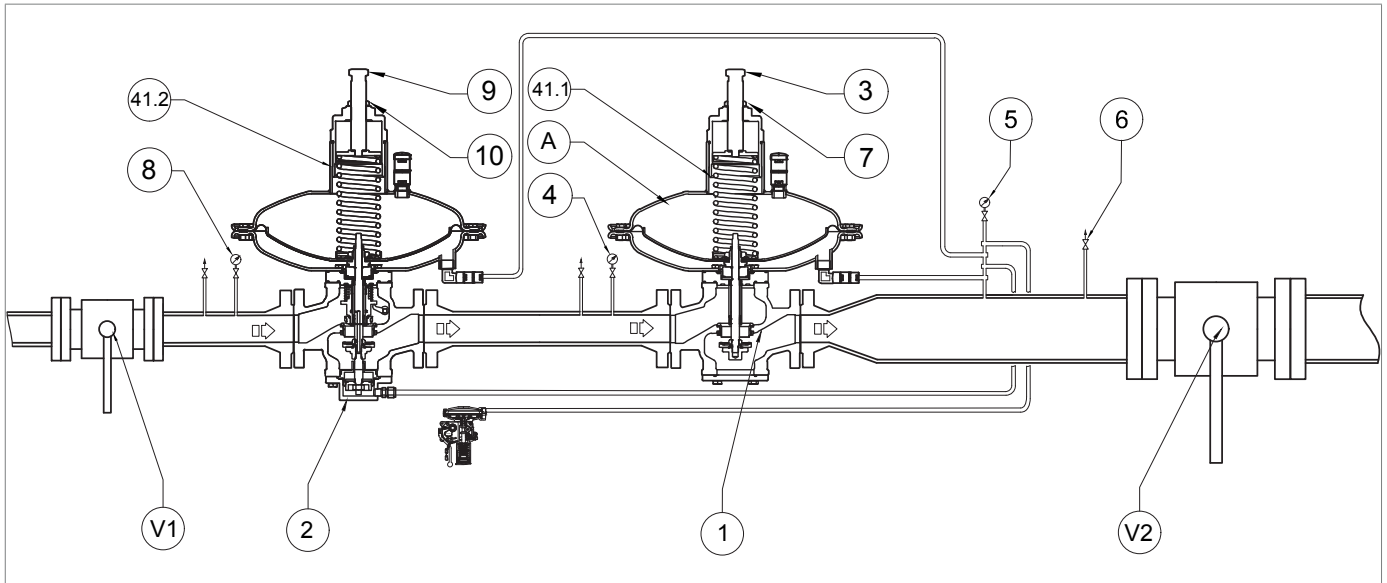

Fig. 8.25. Commissioning of NORVAL regulator + regulator with in-line monitor + SN slam-shut valve function

Step	Action
1	Make sure that the bleed cock (6) is partially open.
2	Check that the SN slam-shut valve is in the closed position. ! NOTICE! If the SN slam-shut valve is in the open position, close it using the manual button (fig. 8.23, ref. 10).
3	Slowly open the upstream shut-off valve (V1), checking the pressure indicated by the upstream pressure gauge (4).
4	Perform the internal tightness check of the SN slam-shut valve, referring to chapter 8.7.1. ! NOTICE! In case of leaks, refer to chapter 10 "Troubleshooting" to clear the causes of the malfunctions.
5	Make sure that the bleed cock (6) is partially open.
6	Slowly pressurise the regulation line, acting on the lever of the SN slam-shut valve (refer to section "Operation" in par. 4.5.4.1), checking that the downstream pressure (Pd) indicated on the downstream pressure gauge (5) does not exceed the required calibration value by over 50%.

Step	Action
7	<p>When the regulator is put into service, the pressure on the downstream pressure gauge (5) will be equal to the calibration value of the main regulator.</p> <p>! NOTICE!</p> <p>In the first line pressurisation phase, the pressure on the downstream pressure gauge (5) could exceed the required calibration value, depending on the response time of the regulator.</p>
8	Check calibrations of the pressure switch of the SN slam-shut valve by referring to paragraph 8.7.3.
9	<p>! NOTICE!</p> <p>With regulators with calibration pressure up to 80 mbar, the response time is longer than that of regulators with calibration pressure above 80 mbar. This is due to the difference in volume of the control heads of the regulators.</p>
10	When the main regulator (1) is put into service, the downstream pressure (Pd) indicated on the downstream pressure gauge (5) will be equal to the calibration value of the regulator (1).
11	<p>Check that the regulator with in-line monitor function (2) is fully open (100%).</p> <p>! NOTICE!</p> <p>The regulator with monitor function (2) is fully open, when the pressure indicated on the intermediate pressure gauge (4) is the same as the upstream pressure gauge (8).</p>
12	Open the upstream shut-off valve (V1) completely.
13	<p>Increase the downstream pressure value (Pd) beyond the calibration pressure of the regulator with monitor function (2), by turning the adjustment screw (3) of the main regulator (1) clockwise.</p> <p>! NOTICE!</p> <p>If the setting spring of the main regulator (1) does not reach a sufficient pressure to trip the regulator with in-line monitor function (2), pressurise the chamber (A) by using an external source (see par. 8.6.1).</p> <p>! NOTICE!</p> <p>The value of the pressure introduced by the external source can be up to 50% more than the calibration value of the regulator with in-line monitor function (2).</p>
14	Check that the regulator with in-line monitor function (2) is running, checking that the pressure indicated on the intermediate pressure gauge (4) is equal to the calibration value of the regulator with in-line monitor function (2).
15a	<p>FOR INITIAL COMMISSIONING OF THE REGULATION LINE</p> <p>If the downstream pressure (Pd) is not at the required calibration value for the regulator with in-line monitor function (2), proceed as follows:</p> <ul style="list-style-type: none"> • downstream pressure value (Pd) lower than required calibration value: load the setting spring by turning the adjustment screw clockwise (9) • downstream pressure value (Pd) higher than required calibration value: load the setting spring by turning the adjustment screw anti-clockwise (9)
15b	<p>AFTER MAINTENANCE OF THE REGULATION LINE</p> <ul style="list-style-type: none"> • load the setting spring (41.2) and increase the pressure value of the regulator with in-line monitor function (2) by turning the adjustment screw clockwise (9)



Commissioning of NORVAL regulator + regulator with in-line monitor + SN slam-shut valve function

Step	Action
16	<p>Check the calibration value of the regulator with in-line monitor function (2), referring to the downstream pressure gauge (5).</p> <div style="border: 1px solid blue; padding: 5px;"> <p>! NOTICE! If the calibration pressure is not as pre-established, repeat steps 15a (first commissioning) or 15b (after maintenance).</p> </div>
17	Slowly close the bleed cock (6).
18	<p>Check that the downstream pressure, after an increment phase, does not exceed the closing pressure value of the regulator with in-line monitor function (2) (refer to the SG value displayed on the plate, see par. 2.8).</p> <div style="border: 1px solid blue; padding: 5px;"> <p>! NOTICE!</p> <ul style="list-style-type: none"> • If the downstream pressure exceeds the closing pressure value, refer to chapter 10 “Troubleshooting” to clear the causes of the malfunctions. • Check the pressure referring to the downstream pressure gauge (5). </div>
19	Partially open the bleed cock (6).
20	Discharge the regulation spring (41.1) of the main regulator (1) or disconnect the external pressure source from the chamber (A) (see par. 8.6.1).
21	<p>Check that the regulator with in-line monitor function (2) is fully open (100%).</p> <div style="border: 1px solid blue; padding: 5px;"> <p>! NOTICE! The regulator with monitor function (2) is fully open, when the pressure indicated on the intermediate pressure gauge (4) is the same as the upstream pressure gauge (8).</p> </div>
22	Check that the calibration pressure of the main regulator (1) is as pre-established by referring to the pressure value indicated on the downstream pressure gauge (5).
23a	<p>FOR INITIAL COMMISSIONING OF THE REGULATION LINE</p> <p>If the pressure downstream (P_d) is not at the required calibration value, proceed as follows:</p> <ul style="list-style-type: none"> • downstream pressure value (P_d) lower than required calibration value: load the setting spring by turning the adjustment screw clockwise (3) • downstream pressure value (P_d) higher than required calibration value: load the setting spring by turning the adjustment screw anti-clockwise (3)

Step	Action
	AFTER MAINTENANCE OF THE REGULATION LINE
23b	<ul style="list-style-type: none"> load the setting spring (41.1) and increase the pressure value of the main regulator (1) by turning the adjustment screw clockwise (3)
24	Slowly close the bleed cock (6).
	Check that the downstream pressure, after an increment phase, does not exceed the closing pressure value of the main regulator (1) (refer to the SG value displayed on the plate, see par. 2.8).
25	<div style="border: 1px solid black; padding: 5px;"> <p>! NOTICE!</p> <ul style="list-style-type: none"> If the downstream pressure exceeds the closing pressure value, refer to chapter 10 “Troubleshooting” to clear the causes of the malfunctions. Check the pressure referring to the downstream pressure gauge (5). </div>
26	Using a foaming agent, check all the junctions between shut-off valves (V1, V2) for proper sealing.
27	If external leaks are noticed, eliminate the leak points and repeat the procedure from step 10.
	Open the downstream shut-off valve (V2) very slowly until the pipeline fills completely.
28	<div style="border: 1px solid black; padding: 5px;"> <p>! NOTICE!</p> <ul style="list-style-type: none"> If the pressure of the downstream pipeline is lower than the calibration pressure, shutter the opening of the downstream shut-off valve (V2) so as to not to exceed the maximum flow rate value of the installation. Check the pressure referring to the downstream pressure gauge (5). </div>
29	Block the adjustment screw (9) with the fixing nut (10) of the regulator with in-line monitor function (2).
30	Block the adjustment screw (3) with the fixing nut (7) of the main regulator (1).

Tab. 8.56.

COMMISSIONING OF SN SLAM-SHUT VALVE

! NOTICE!

Refer to paragraph 8.7.3 “Calibration procedure for pressure switches mod. SN-91, SN-92 for the SN slam-shut valve”.

8.9 - DEVICE CALIBRATION

8.9.1 - CALIBRATION OF PRESSURE SWITCHES MOD. SN-91, SN-92

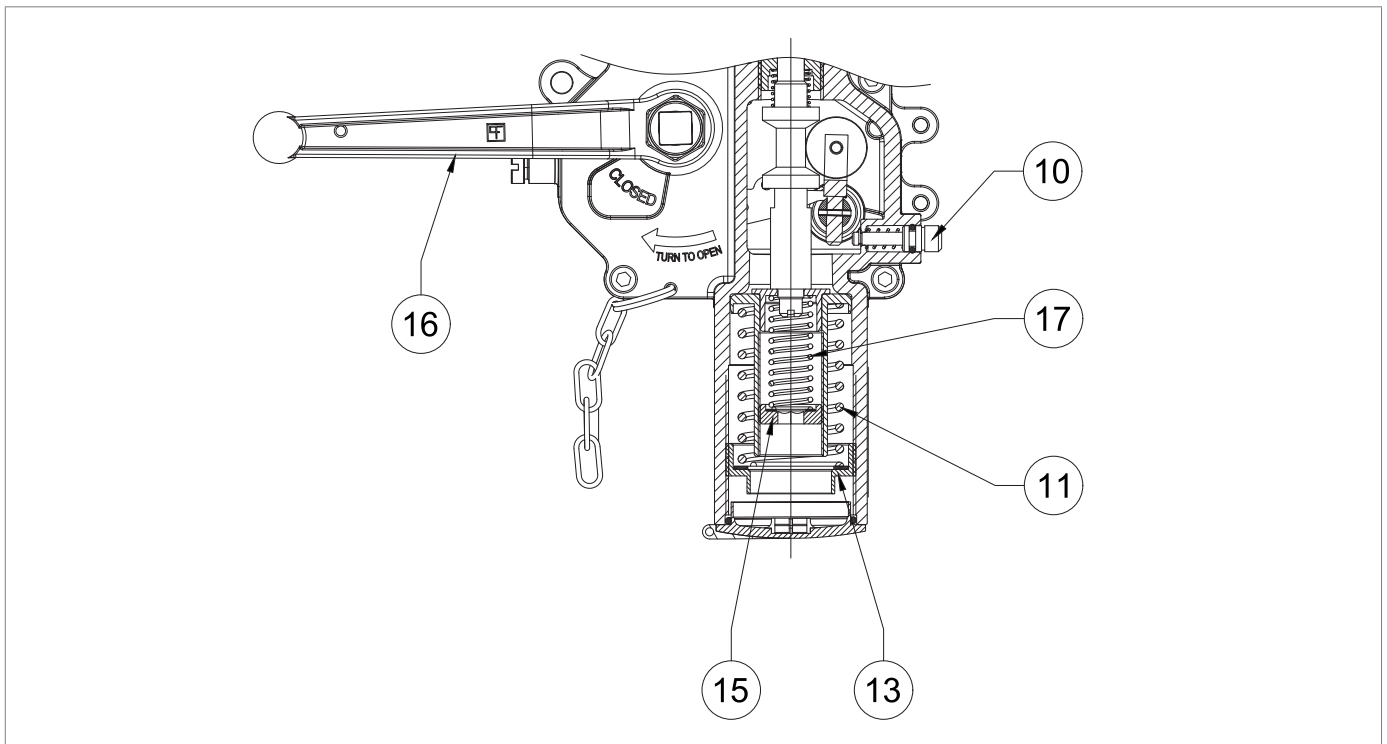

Fig. 8.26. Calibration of pressure switches mod. SN-91, SN-92

Act on the ring nut (13) for maximum tripping (spring ref. 11):

- anticlockwise to decrease the slam-shut device tripping pressure;
- clockwise to increase the slam-shut device tripping pressure.

Act on the ring nut (15) for minimum tripping (spring ref. 17):

- anticlockwise to decrease the slam-shut device tripping pressure;
- clockwise to increase the slam-shut device tripping pressure.

NOTICE!

For calibration ranges, please refer to chapter 13 “Calibration tables”.

ATTENTION!

After having calibrated and reset the pressure switch, remove the lever to avoid interferences with other objects in the system.

9 - MAINTENANCE AND FUNCTIONAL CHECKS

9.1 - GENERAL WARNINGS

HAZARD!

- Maintenance work must be carried out by qualified personnel trained on safety in the workplace and authorised to carry out equipment-related activities.
- Each maintenance operation requires in-depth and specialised knowledge of the equipment, the necessary operations, the associated risks and the correct procedures to operate safely.
- Repair or maintenance work not provided for in this manual may be carried out only if approved by PIETRO FIORENTINI S.p.A.. PIETRO FIORENTINI S.p.A. shall not be held liable for damage to persons or property resulting from operations other than those described herein or carried out in ways other than as indicated.

WARNING!

Before conducting any work, make sure that the line on which the equipment is installed:

- has been shut off downstream and upstream;
- has been discharged.

WARNING!

In case of doubt, do not perform any work. Contact PIETRO FIORENTINI S.p.A. for the necessary clarifications.

Managing and/or using the equipment includes operations that are necessary as a result of normal use such as:

- inspection and checks;
- functional checks;
- routine maintenance;
- special maintenance.

NOTICE!

Maintenance work is strictly related to:

- the quality of the conveyed gas (impurities, humidity, gasoline, corrosive substances);
- the effectiveness of filtration;
- the equipment conditions of use.

To properly run the equipment, one should:

- follow the service frequency referred to in the manual for functional checks and routine maintenance.
- not exceed the time interval between one service and the next. The time interval is to be understood as the maximum acceptable; it can, however, be shortened;
- promptly check the causes of any anomalies such as excessive noise, leakage of fluids or similar and remedy them. The timely removal of any causes of anomaly and/or malfunction prevents further damage to the equipment and ensures operator safety;

Before beginning disassembly of the equipment, make sure that:

- the spare parts and parts used in replacements have adequate requirements to ensure the original performance of the equipment. Use conforming original spare parts;
- the operator has the necessary equipment (see chapter 7 “Commissioning/maintenance equipment”).

! NOTICE!

The recommended spare parts are unambiguously identified with tags indicating:

- **the assembly drawing number of the equipment where they are installed (see Chapter 12 “Recommended spare parts”);**
- **The position specified in the assembly drawing of the equipment.**



The equipment maintenance operations are divided, from an operational point of view, into three main categories:

Commissioning and maintenance operations

Periodic checks and inspections	All those checks that the operator must carry out on a regular basis to ensure that the equipment is in proper working order.
Routine maintenance	All those operations that the operator must preventively carry out to ensure proper operation of the device over time. Routine maintenance includes: <ul style="list-style-type: none"> • inspection; • control; • adjustment; • cleaning; • lubrication; • replacement; of all spare parts.
Special maintenance	All those operations to be carried out by the operator as required by the equipment.

Tab. 9.57.

9.2 - PERIODICALLY CHECKING AND INSPECTING THE EQUIPMENT FOR PROPER OPERATION

Periodic checks and inspections	
Operator qualification	Mechanical maintenance technician
PPE required	 <div style="background-color: orange; padding: 5px; margin-top: 10px;">  WARNING! </div> <p>The PPE listed in this table is related to the risk associated with the equipment. For the PPE required to protect against risks associated with the workplace, installation or operating conditions, please refer to:</p> <ul style="list-style-type: none"> • the regulations in force in the country of installation; • <u>any information provided by the Safety Manager at the installation facility.</u>

Tab. 9.58.

Table 9.59 lists the checks and inspections, i.e. the operations that do not require any manual service on the equipment.

Some items thereof can be replaced remotely using suitable remote control tools. The following is listed below:

Activity description	Equipment/accessories involved	Evaluation criterion	Minimum frequency
Significant performance check*	Pressure regulators	<ul style="list-style-type: none"> • No fluctuations in the adjusted pressure. • Significant pressure values within pre-set limits. 	Monthly
	Gas flow slam-shut type safety devices (external position indicator)	<ul style="list-style-type: none"> • Fully open position. 	
	Stand-by monitor (external position indicator)	<ul style="list-style-type: none"> • Fully open position. 	
Visual inspection of the equipment outside condition	All	<ul style="list-style-type: none"> • No visible damage. • External surface protection as per UNI 9571-1:2012. 	Half-yearly

Tab. 9.59.

* These checks may be carried out remotely if there is a remote control system capable of analysing the significant performance of the equipment and of sending alerts/alarms when pre-set thresholds are reached.

9.3 - ROUTINE MAINTENANCE

9.3.1 - GENERAL SAFETY WARNINGS

 **HAZARD!**

- Put the equipment in a safe condition (close the downstream shut-off valve and then the upstream one, and drain the line completely);
- ensure that the pressure upstream and downstream of the equipment is “0”.

 **NOTICE!**

Before installing new sealing elements (O-rings, diaphragm, etc.), they must be checked for integrity.

9.3.2 - REPLACEMENT FREQUENCY FOR COMPONENTS SUBJECT TO WEAR

NOTICE!

The following provisions shall apply to equipment components only.

The non-metallic parts of the equipment concerned are divided into the following two categories:

Preventive maintenance work	
Category 1	Parts subject to wear and/or abrasion, where: <ul style="list-style-type: none"> wear and tear means the normal degradation of a part after prolonged use under normal operating conditions; abrasion is the mechanical action on the surface of the affected part resulting from the passage of gas under normal operating conditions.
Category 2	Parts subject to aging only, including parts that also require lubrication and/or cleaning.

Tab. 9.60.

NOTICE!

Check, within the minimum frequency specified in Tab. 9.61, the available components for wear/abrasion/aging.

Category	Part description	Evaluation criterion	Minimum replacement frequency
1	Sealing rings for non-metallic valve seats and plugs	Pressure regulators	6 years
		Safety devices	
		Pressure safety system equipment	
1	Non-metallic parts with internal sealing function of valve seats and accessories of individual equipment	Pilots	6 years
		Pre-regulators	
		Accelerators	
		Any others	
1	Non-metallic parts with a sealing function between parts, at least one of which is in motion under normal working/operating conditions	Pressure regulators	6 years
		Gas flow slam-shut type safety devices	
		Relief devices with discharge to atmosphere	
1	Non-metallic parts with sealing function involved in disassembly operations during maintenance	Equipment subject to maintenance	6 years
2	Non-metallic parts providing feedback (sensing elements) of the controlled pressure of safety equipment	Safety equipment and/or accessories	6 years
2	Non-metallic parts with sealing and performance functions (diaphragms) of equipment	Pressure regulators and accessories	6 years
		Gas flow slam-shut type safety devices	6 years
		Relief device with discharge to atmosphere	6 years
2	Non-metallic parts of equipment with an internal sealing function: under normal operating conditions during maintenance	Relief valves	6 years
		Regulation lines disconnection equipment	If there are ascertained leaks

Category	Part description	Evaluation criterion	Minimum replacement frequency
2	Non-metallic parts with a static sealing function only	Miscellaneous equipment	If there are ascertained leaks
2	Lubricating parts	Shut-off valves	Yearly
		Other equipment	Yearly
2	Filter elements	Filters	As needed

Tab. 9.61.

9.4 - ROUTINE MAINTENANCE PROCEDURES

Routine maintenance	
Operator qualification	Mechanical maintenance technician
PPE required	 <p>⚠ WARNING!</p> <p>The PPE listed in this table is related to the risk associated with the equipment. For the PPE required to protect against risks associated with the workplace, installation or operating conditions, please refer to:</p> <ul style="list-style-type: none"> • the regulations in force in the country of installation; • <u>any information provided by the Safety Manager at the installation facility.</u>
Equipment required	Refer to chapter 7 "Equipment for commissioning/maintenance".

Tab. 9.62.

9.4.1 - TIGHTENING TORQUES NORVAL

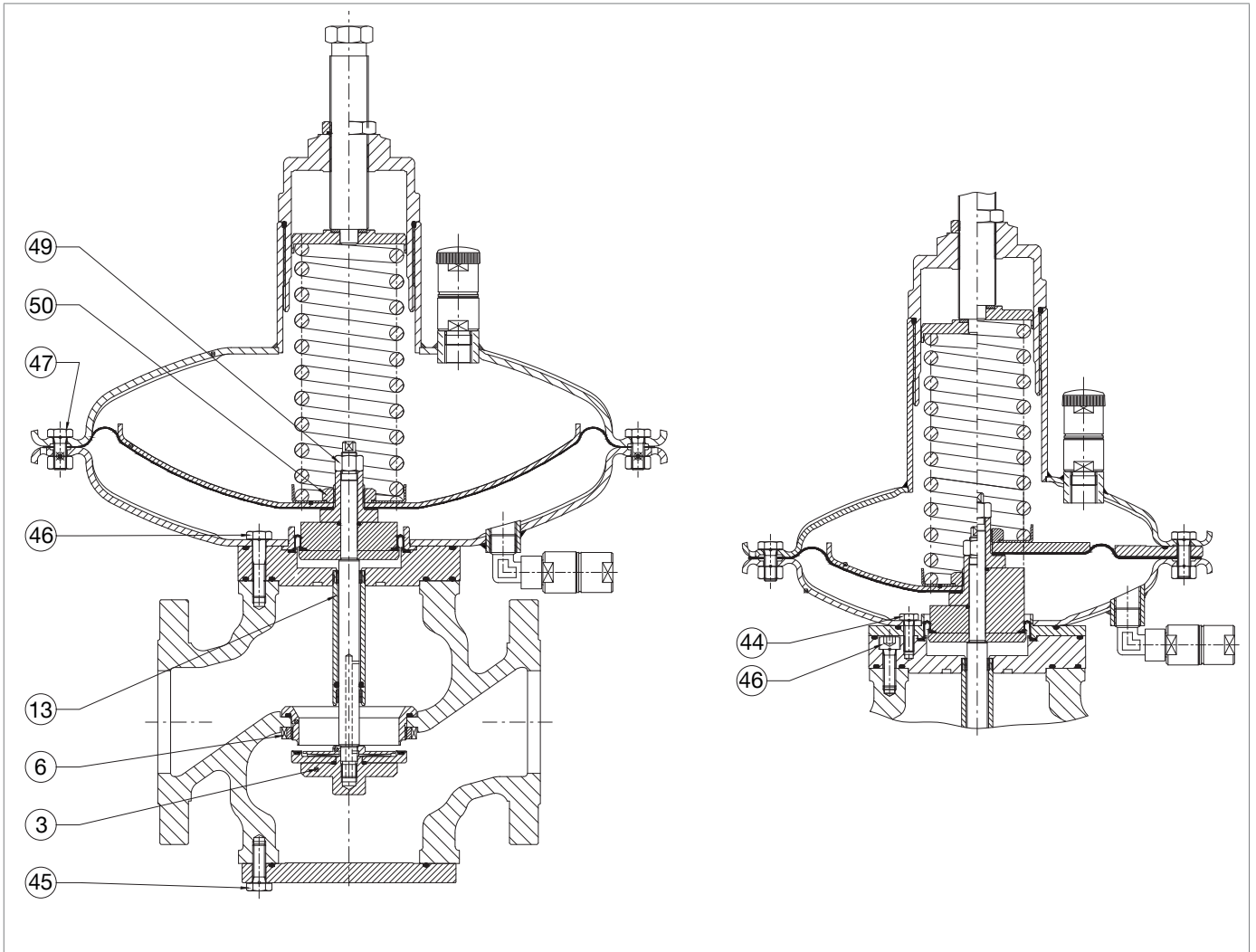

Fig. 9.27. Tightening torques NORVAL 1 - 3

NORVAL 1" (HEADS 375TR, 375, 495)

Pos.	Description	Torque (Nm)	Torque (ft - lb)
3	Gasket support M12X1.25	20	14
6	Fixing ring nut M45	50	36
45	Screw M8X25 UNI 5739	30	22
46	Screw M8X35 UNI 5737	30	22
47	Screw M10X25 / M10X30 UNI 5739	25	18
49	Nut M12X1.25 UNI 7473	40	29
50	Nut M24X2	40	29

Tab. 9.63.
NORVAL 1" ½ (HEADS 375TR, 375, 495)

Pos.	Description	Torque (Nm)	Torque (ft - lb)
3	Gasket support M12X1.25	20	14
6	Fixing ring nut M60	50	36
45	Screw M10X25 UNI 5739	50	36
46	Screw M10X40 UNI 5737	50	36
47	Screw M10X25 / M10X30 UNI 5739	25	18
49	Nut M12X1.25 UNI 7473	40	29
50	Nut M24X2	40	29

Tab. 9.64.
NORVAL 2" (HEADS 375TR, 375, 495)

Pos.	Description	Torque (Nm)	Torque (ft - lb)
3	Gasket support M12X1.25	20	14
6	Fixing ring nut M60	50	36
45	Screw M10X25 UNI 5739	50	36
46	Screw M10X40 UNI 5737	50	36
47	Screw M10X25 / M10X30 UNI 5739	25	18
49	Nut M12X1.25 UNI 7473	40	29
50	Nut M24X2	40	29

Tab. 9.65.
NORVAL 2" ½ (HEADS 375TR, 375)

Pos.	Description	Torque (Nm)	Torque (ft - lb)
3	Gasket support M12X1.25	20	14
6	Fixing ring nut M90	50	36
44	Screw M8X25 UNI 5931	30	22
45	Screw M10X30 UNI 5739	50	36
46	Screw M10X30 UNI 5737	50	36
47	Screw M10X25 / M10X30 UNI 5739	25	18
49	Nut M12X1.25 UNI 7473	40	29
50	Nut M24X2	40	29

Tab. 9.66.

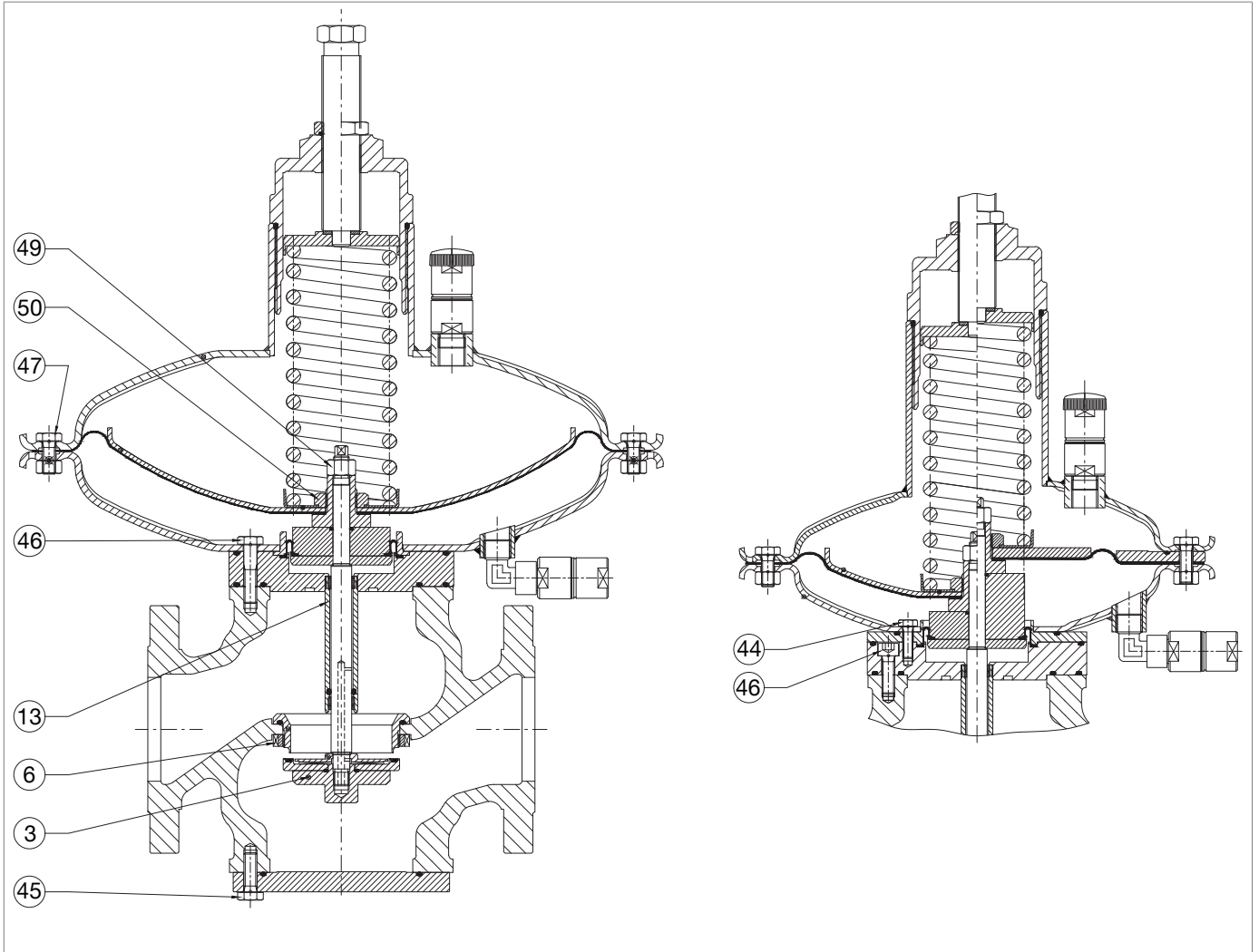

Tightening torques NORVAL 1 - 3

NORVAL 2" ½ (HEADS 495, 630)

Pos.	Description	Torque (Nm)	Torque (ft - lb)
3	Gasket support M12X1.25	20	14
6	Fixing ring nut M90	50	36
45	Screw M10X30 UNI 5739	50	36
46	Screw M10X45 UNI 5737	50	36
47	Screw M10X25 UNI 5739	25	18
49	Nut M12X1.25 UNI 7473	40	29
50	Nut M24X2	40	29

Tab. 9.67.
NORVAL 3" (HEADS 375TR, 375)

Pos.	Description	Torque (Nm)	Torque (ft - lb)
3	Gasket support M12X1.25	20	14
6	Fixing ring nut M90	50	36
44	Screw M8X25 UNI 5931	30	22
45	Screw M10X30 UNI 5739	50	36
46	Screw M10X30 UNI 5737	50	36
47	Screw M10X25 / M10X30 UNI 5739	25	18
49	Nut M12X1.25 UNI 7473	40	29
50	Nut M24X2	40	29

Tab. 9.68.
NORVAL 3" (HEADS 495, 630)

Pos.	Description	Torque (Nm)	Torque (ft - lb)
3	Gasket support M12X1.25	20	14
6	Fixing ring nut M90	50	36
45	Screw M10X30 UNI 5739	50	36
46	Screw M10X45 UNI 5737	50	36
47	Screw M10X25 UNI 5739	25	18
49	Nut M12X1.25 UNI 7473	40	29
50	Nut M24X2	40	29

Tab. 9.69.

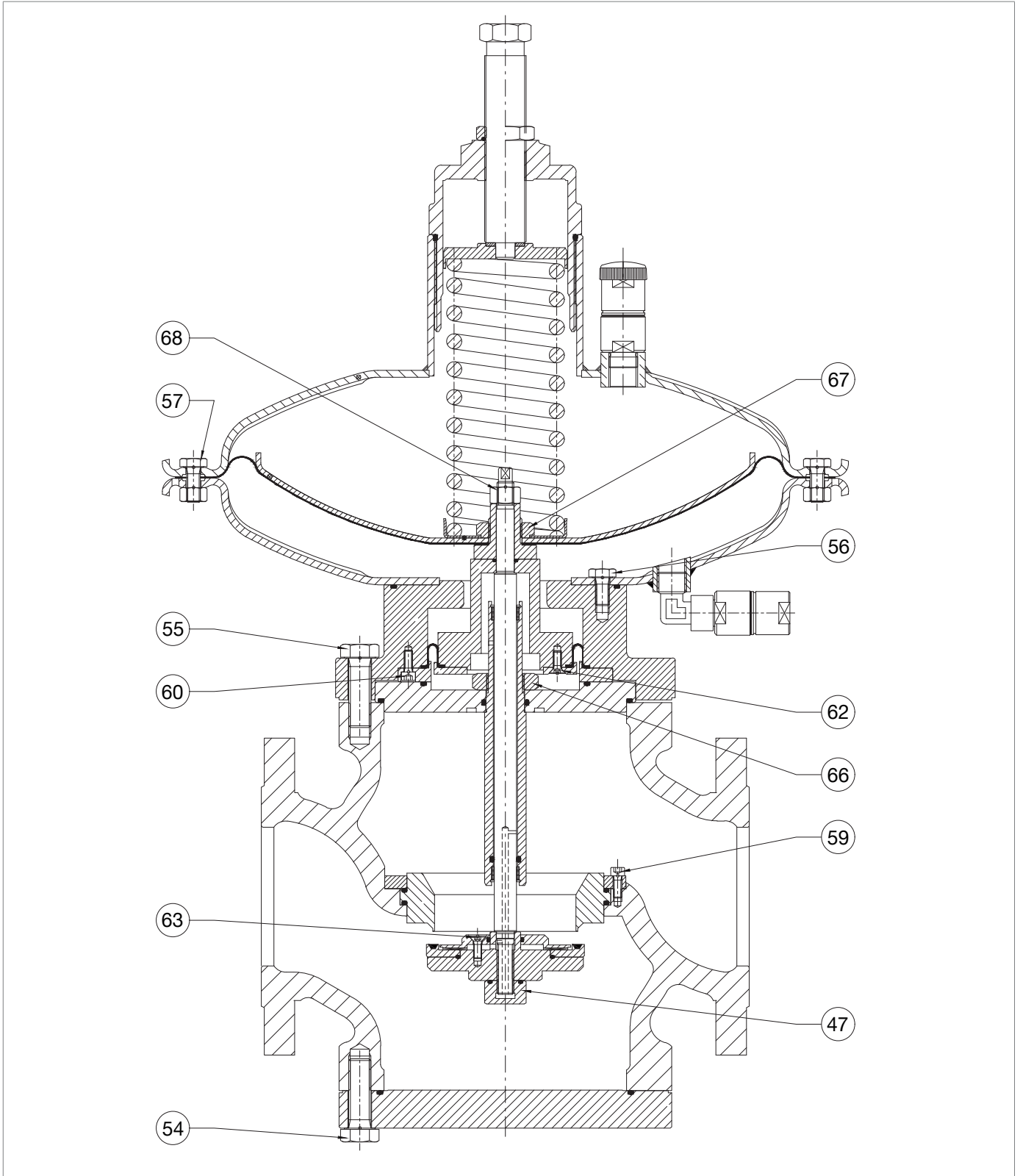

Tightening torques NORVAL

NORVAL 4" (HEADS 375TR, 375, 495, 630)

Pos.	Description	Torque (Nm)	Torque (ft - lb)
47	Nut M12X1.25	35	25
54	Screw M16X50 UNI 5737	150	110
55	Screw M16X50 UNI 5737	150	110
56	Screw M10X20 UNI 5739	50	36
57	Screw M10X25 UNI 5739	25	18
59	Screw M6X16 UNI 5931	10	7
60	Screw M6X14 UNI 5931	10	7
62	Screw M6X14 UNI 5933	10	7
63	Screw M6X16 UNI 5933	10	7
66	Nut M27X2	80	59
67	Nut M24X2	40	29
68	Nut M12X1.25 UNI 7473	40	29

Tab. 9.70.
NORVAL 6" (HEADS 495, 630)

Pos.	Description	Torque (Nm)	Torque (ft - lb)
47	Nut M16X1.5	35	25
54	Screw M14X50 UNI 5737	115	84
55	Screw M14X60 UNI 5737	115	84
56	Screw M10X35 UNI 5739	50	36
57	Screw M10X25 UNI 5739	25	18
59	Screw M6X16 / M6X20 UNI 5931	10	7
60	Screw M6X16 / M6X30 UNI 5931	10	7
62	Screw M6X16 UNI 5933	10	7
63	Screw M6X16 / M6X20 UNI 5933	10	7
66	Nut M33X1.5	80	59
67	Nut M24X2	60	44
68	Nut M14X1.5 UNI 7473	50	36

Tab. 9.71.

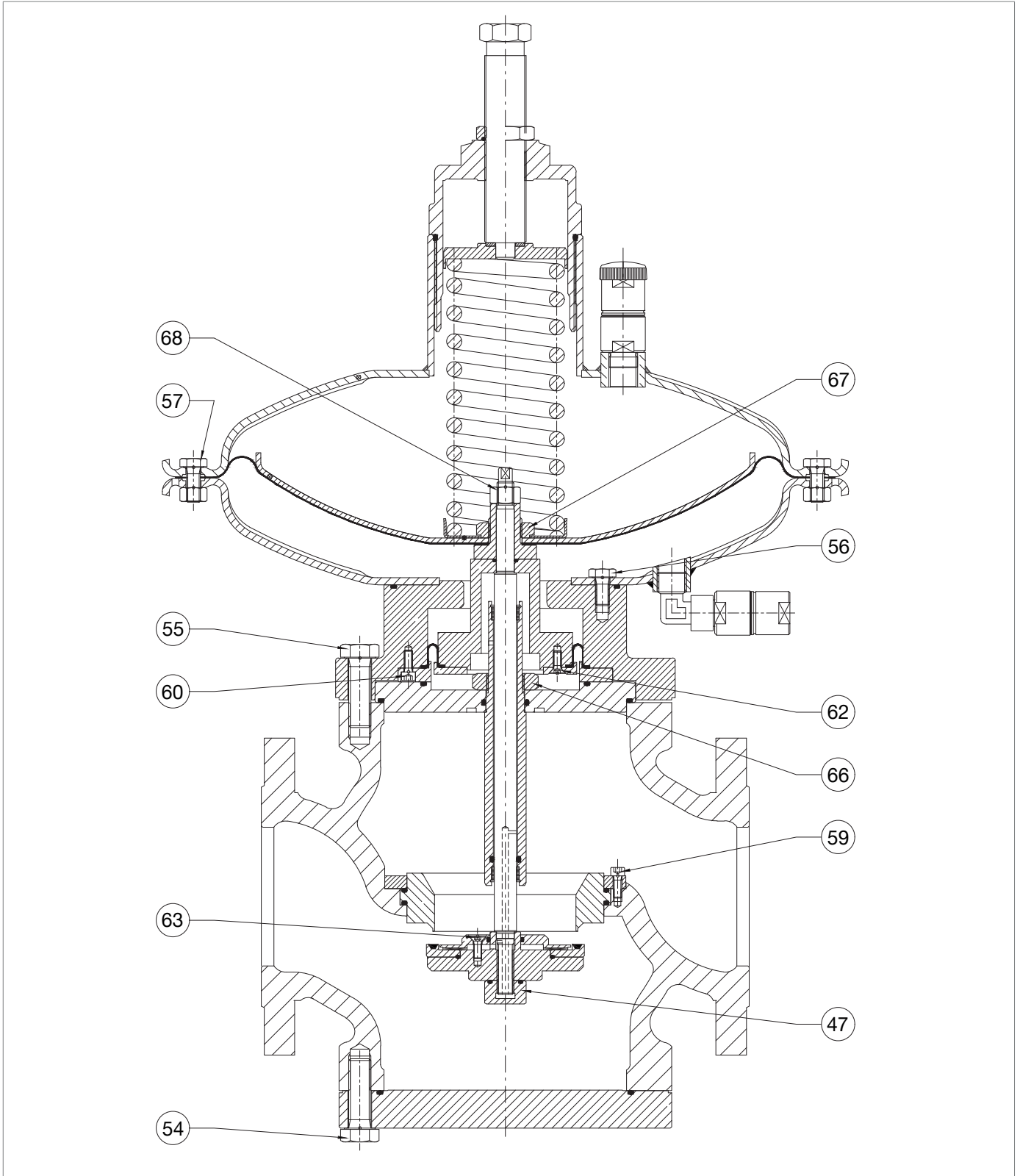

Tightening torques NORVAL

NORVAL 8" (HEADS 495, 630)

Pos.	Description	Torque (Nm)	Torque (ft - lb)
47	Nut M16X1.5	35	25
54	Screw M14X50 UNI 5737	115	84
55	Screw M14X60 UNI 5737	115	84
56	Screw M10X35 UNI 5739	50	36
57	Screw M10X25 UNI 5739	25	18
59	Screw M6X16 / M6X20 UNI 5931	10	7
60	Screw M6X16 / M6X30 UNI 5931	10	7
62	Screw M6X16 UNI 5933	10	7
63	Screw M6X16 / M6X20 UNI 5933	10	7
66	Nut M33X1.5	80	59
67	Nut M24X2	40	29
68	Nut M14X1.5 UNI 7473	50	36

Tab. 9.72.

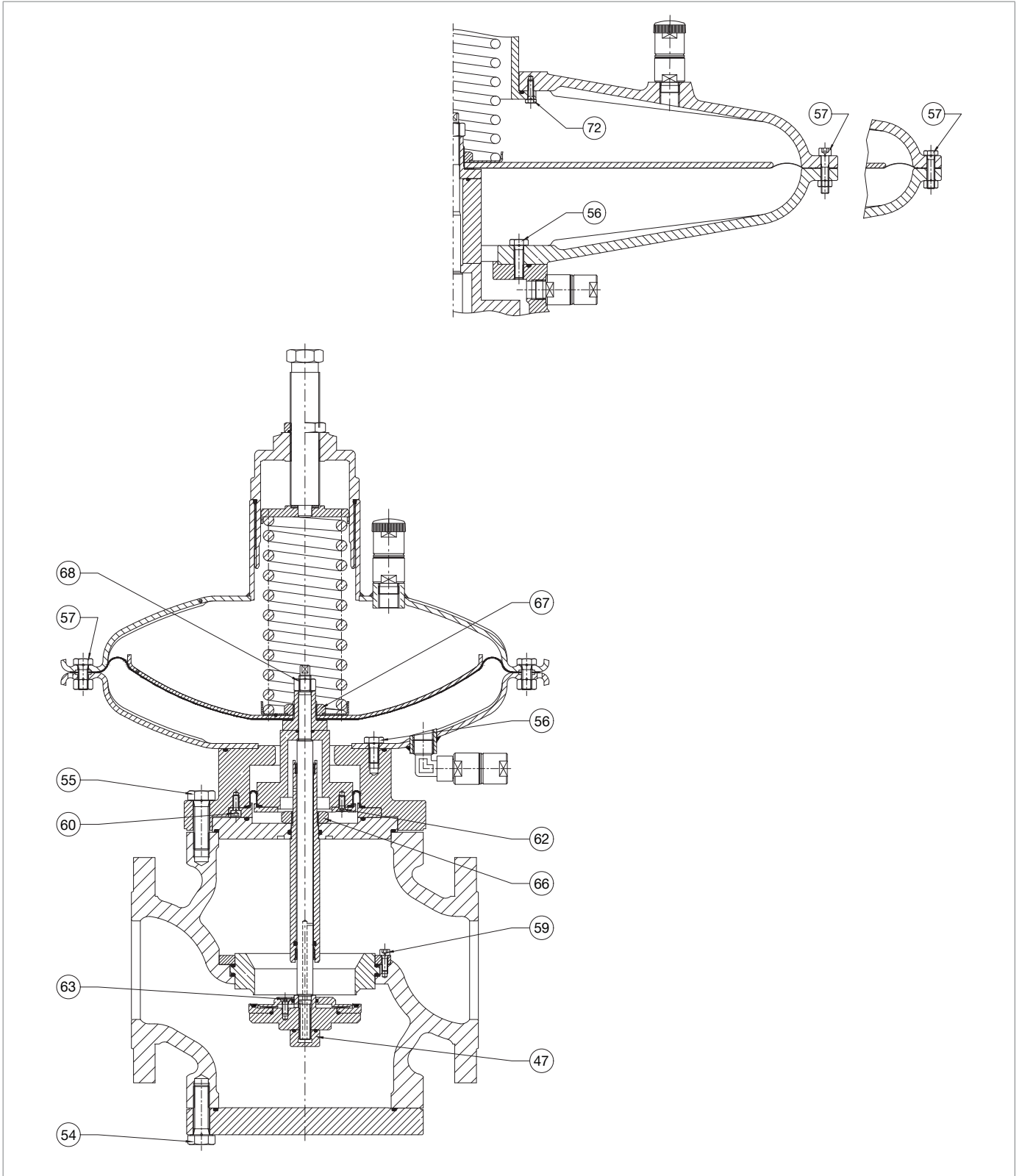

Tightening torques NORVAL

NORVAL 6" (HEAD 658)

Pos.	Description	Torque (Nm)	Torque (ft - lb)
47	Nut M16X1.5	35	25
54	Screw M14X50 UNI 5737	115	84
55	Screw M14X60 UNI 5737	115	84
56	Screw M10X35 UNI 5739	50	36
57	Screw M8X35 UNI 5737	25	18
59	Screw M6X16 / M6X20 UNI 5931	10	7
60	Screw M6X16 / M6X30 UNI 5931	10	7
62	Screw M6X16 UNI 5933	10	7
63	Screw M6X16 / M6X20 UNI 5933	10	7
66	Nut M33X1.5	80	59
67	Nut M24X2	60	44
68	Nut M14X1.5 UNI 7473	50	36
72	Screw M6X30 UNI 5739	10	7

Tab. 9.73.
NORVAL 8" (HEAD 658)

Pos.	Description	Torque (Nm)	Torque (ft - lb)
47	Nut M16X1.5	35	25
54	Screw M14X50 UNI 5737	115	84
55	Screw M14X60 UNI 5737	115	84
56	Screw M10X35 UNI 5739	50	36
57	Screw M8X35 UNI 5737	25	18
59	Screw M6X16 / M6X20 UNI 5931	10	7
60	Screw M6X16 / M6X30 UNI 5931	10	7
62	Screw M6X16 UNI 5933	10	7
63	Screw M6X16 / M6X20 UNI 5933	10	7
66	Nut M33X1.5	80	59
67	Nut M24X2	40	29
68	Nut M14X1.5 UNI 7473	50	36
72	Screw M6X30 UNI 5739	10	7

Tab. 9.74.

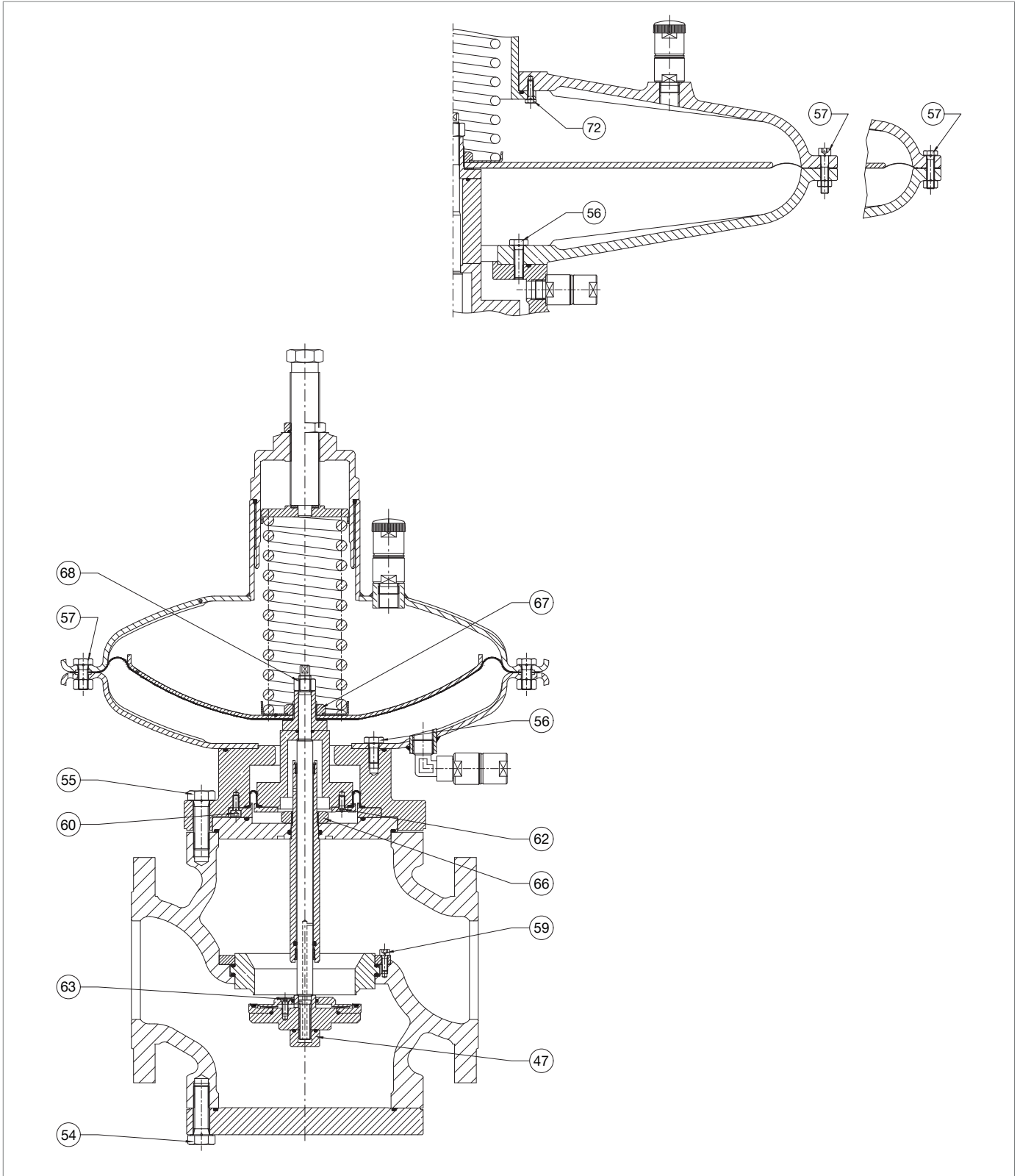

Tightening torques NORVAL

NORVAL 6" (HEAD 817)

Pos.	Description	Torque (Nm)	Torque (ft - lb)
47	Nut M16X1.5	35	25
54	Screw M14X50 UNI 5737	115	84
55	Screw M14X60 UNI 5737	115	84
56	Screw M10X35 UNI 5739	50	36
57	Screw M8X40 UNI 5931	25	18
59	Screw M6X16 / M6X20 UNI 5931	10	7
60	Screw M6X16 / M6X30 UNI 5931	10	7
62	Screw M6X16 UNI 5933	10	7
63	Screw M6X16 / M6X20 UNI 5933	10	7
66	Nut M33X1.5	80	59
67	Nut M24X2	60	44
68	Nut M14X1.5 UNI 7473	50	36
72	Screw M6X30 UNI 5739	10	7

Tab. 9.75.
NORVAL 8" (HEAD 817)

Pos.	Description	Torque (Nm)	Torque (ft - lb)
47	Nut M16X1.5	35	25
54	Screw M14X50 UNI 5737	115	84
55	Screw M14X60 UNI 5737	115	84
56	Screw M10X35 UNI 5739	50	36
57	Screw M8X40 UNI 5931	25	18
59	Screw M6X16 / M6X20 UNI 5931	10	7
60	Screw M6X16 / M6X30 UNI 5931	10	7
62	Screw M6X16 UNI 5933	10	7
63	Screw M6X16 / M6X20 UNI 5933	10	7
66	Nut M33X1.5	80	59
67	Nut M24X2	40	29
68	Nut M14X1.5 UNI 7473	50	36
72	Screw M6X30 UNI 5739	10	7

Tab. 9.76.

9.4.1.1 - ER IN-LINE MONITOR TIGHTENING TORQUES

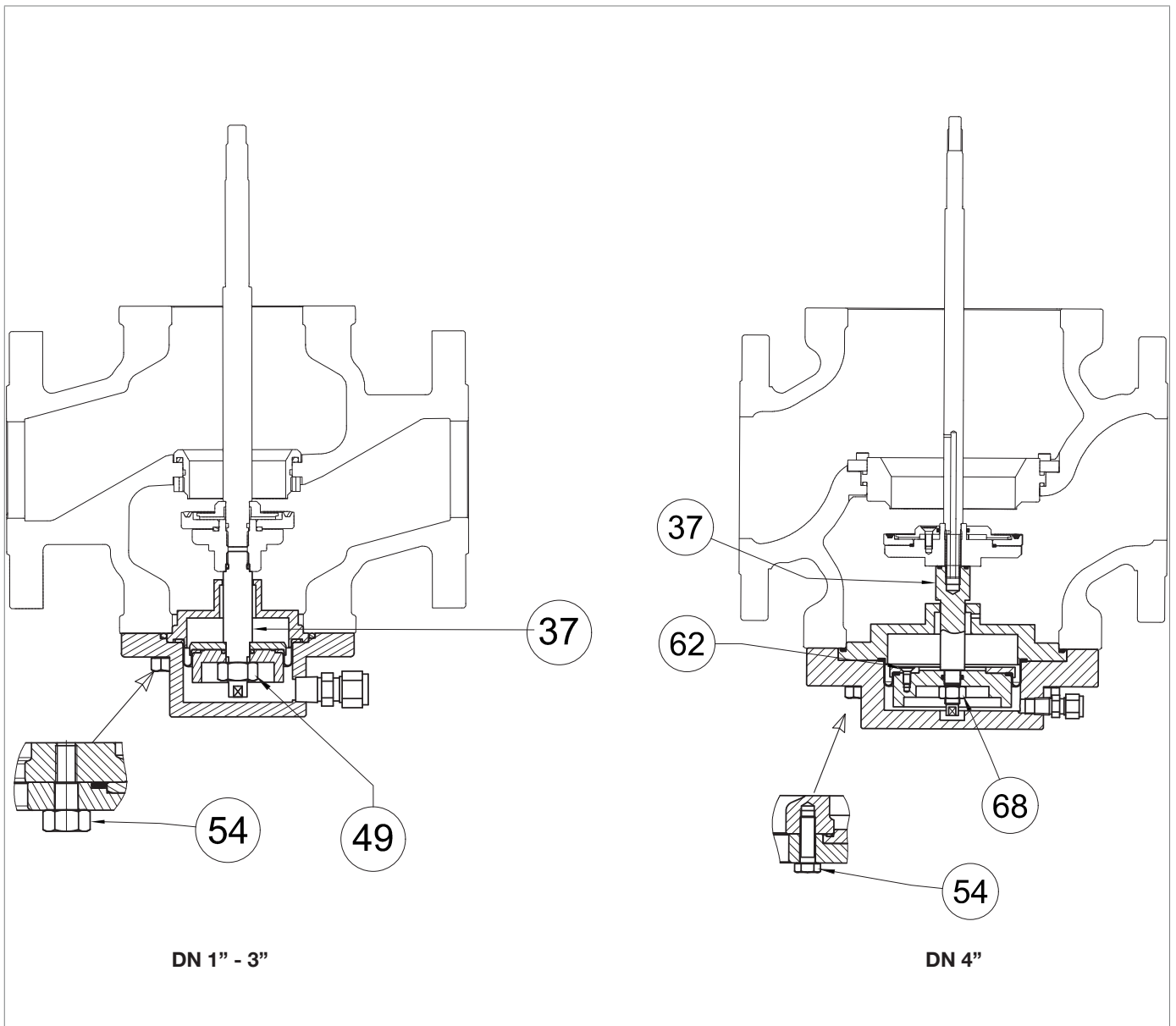

Fig. 9.28. ER in-line monitor tightening torques 1" - 3", 4"

ER 1"

Pos.	Description	Torque (Nm)	Torque (ft - lb)
37	ER monitor rod	20	14
45	Screw M10X30 UNI 5739	30	22
49	Nut M12X1.25 UNI 7473	60	44

Tab. 9.77.
ER 1" ½

Pos.	Description	Torque (Nm)	Torque (ft - lb)
37	ER monitor rod	20	14
45	Screw M10X30 UNI 5739	50	36
49	Nut M12X1.25 UNI 7473	60	44

Tab. 9.78.
ER 2"

Pos.	Description	Torque (Nm)	Torque (ft - lb)
37	ER monitor rod	20	14
45	Screw M10X30 UNI 5739	50	36
49	Nut M12X1.25 UNI 7473	60	44

Tab. 9.79.
ER 2" ½

Pos.	Description	Torque (Nm)	Torque (ft - lb)
37	ER monitor rod	20	14
45	Screw M10X30 UNI 5739	50	36
49	Nut M12X1.25 UNI 7473	60	44

Tab. 9.80.
ER 3"

Pos.	Description	Torque (Nm)	Torque (ft - lb)
37	ER monitor rod	20	14
45	Screw M10X30 UNI 5739	50	36
49	Nut M12X1.25 UNI 7473	60	44

Tab. 9.81.
ER 4"

Pos.	Description	Torque (Nm)	Torque (ft - lb)
37	ER monitor rod	60	44
54	Screw M16X50 UNI 5739	150	110
62	Screw M6X14 UNI 5933	10	7
68	Nut M12X1.25 UNI 7473	60	44

Tab. 9.82.

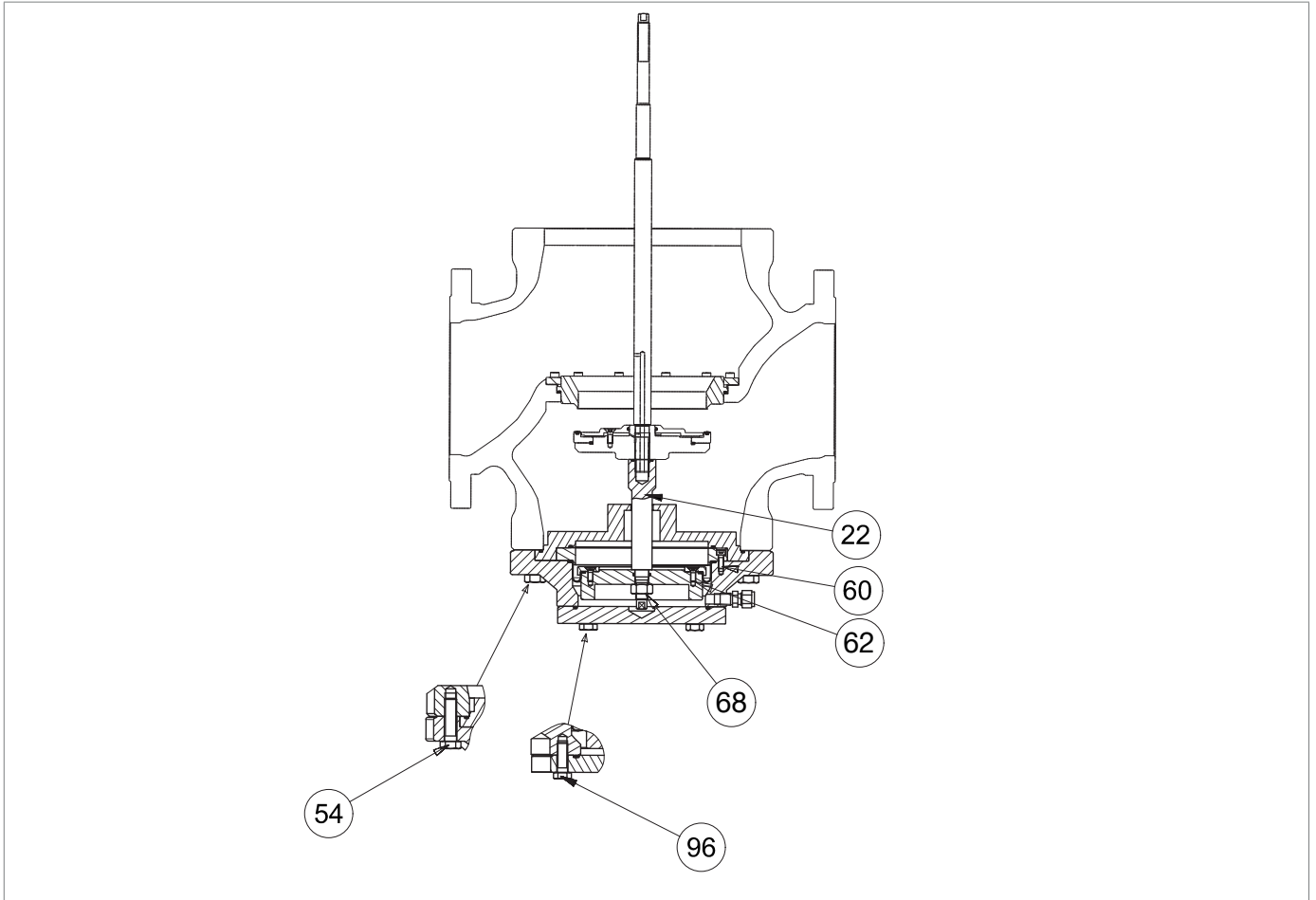

Fig. 9.29. ER incorporated monitor tightening torques 6"-8"

ER 6"

Pos.	Description	Torque (Nm)	Torque (ft - lb)
22	ER monitor rod	60	44
54	Screw M16X50 UNI 5739	115	84
60	Screw M6X14 UNI 5933	10	7
62	Screw M6X14 UNI 5933	10	7
68	Nut M12X1.25 UNI 7473	60	44
96	Screw 12X35 UNI 5739	80	59

Tab. 9.83.
ER 8"

Pos.	Description	Torque (Nm)	Torque (ft - lb)
22	ER monitor rod	60	44
54	Screw M16X50 UNI 5739	115	84
60	Screw M6X14 UNI 5933	10	7
62	Screw M6X14 UNI 5933	10	7
68	Nut M12X1.25 UNI 7473	60	44
96	Screw 12X35 UNI 5739	80	59

Tab. 9.84.

9.4.1.2 - SN SLAM-SHUT VALVE TIGHTENING TORQUES

Fig. 9.30. SN slam-shut valve tightening torques 1" - 3", 4"

SN 1" - 3"

Pos.	Description	Torque (Nm)	Torque (ft - lb)
99	Screw M6X16 UNI 5931	10	7

Tab. 9.85.

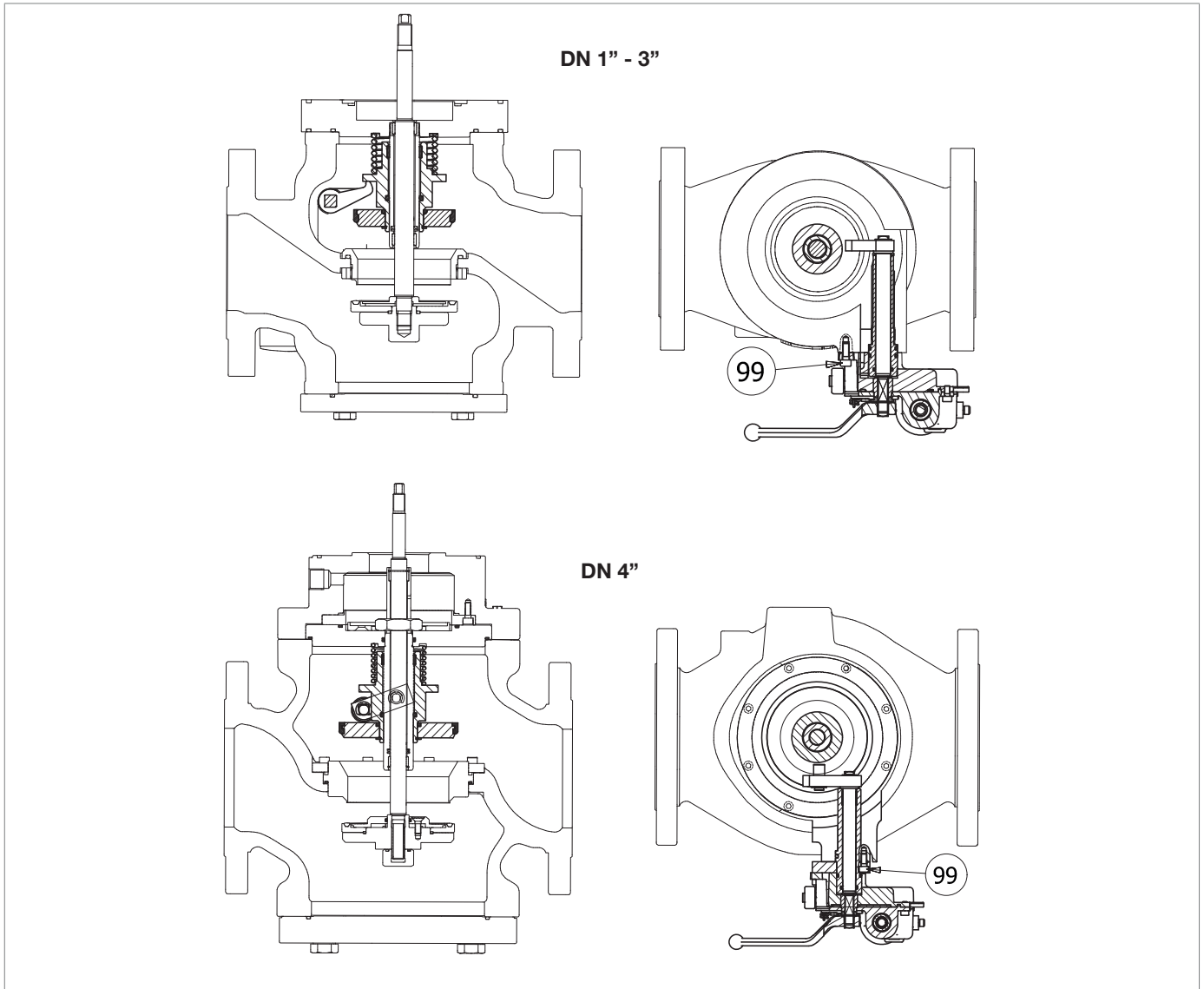
SN 4"

Pos.	Description	Torque (Nm)	Torque (ft - lb)
99	Screw M6X16 UNI 5931	10	7

Tab. 9.86.

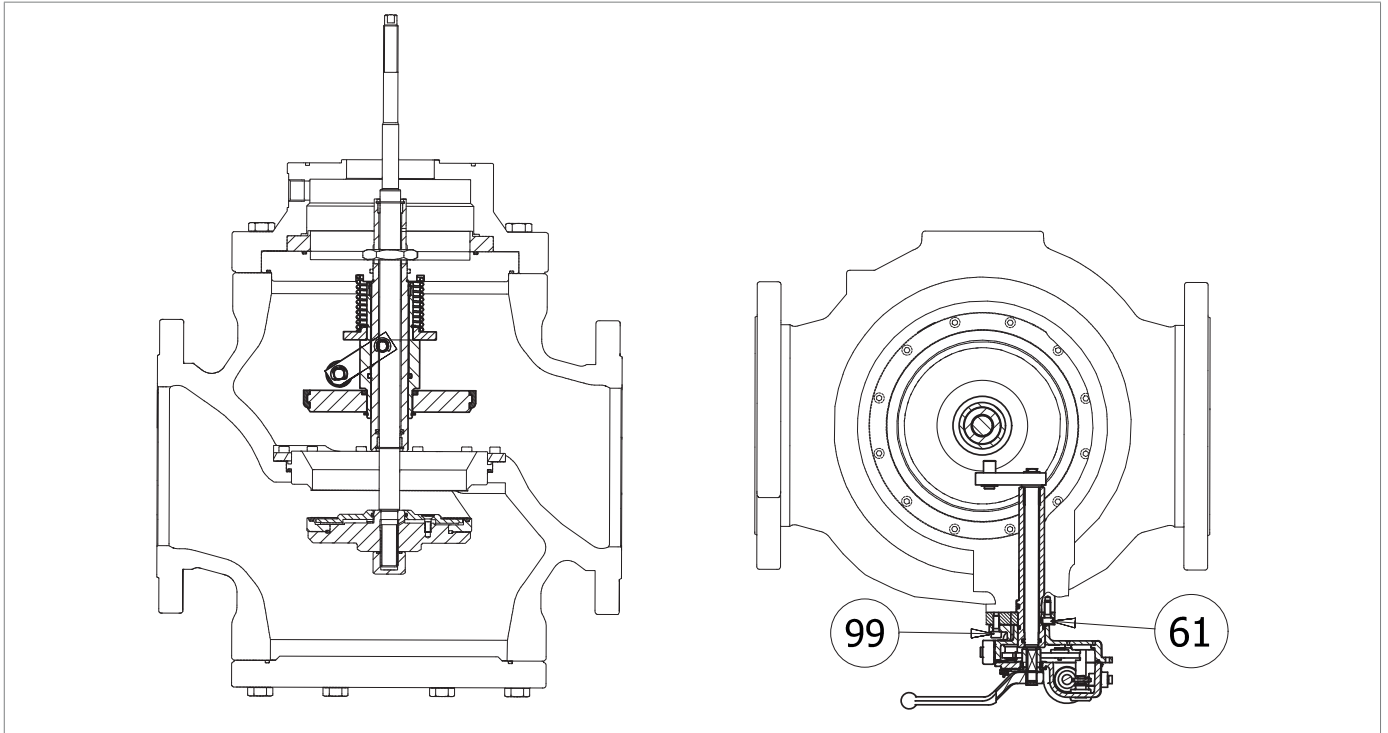

SN slam-shut valve tightening torques 6"-8"

SN 6" - 8"			
Pos.	Description	Torque (Nm)	Torque (ft - lb)
61	Screw M6X16 UNI 5931	10	7
99	Screw M6X16 UNI 5931	10	7

Tab. 9.87.

9.4.1.3 - PRESSURE SWITCH TIGHTENING TORQUE MOD. SN-91, SN-92

Fig. 9.31. Pressure switch tightening torques mod. SN-91, SN-92

SN-91, SN-92			
Pos.	Description	Torque (Nm)	Torque (ft - lb)
18	Slam-shut device guide	45	33
41	Screw M5X10 UNI 5931	4	2
42	Screw M5X20 UNI 5931	5	3
44	Screw M5X10 UNI 5933	5	3
76	Locking nut	12	8

Tab. 9.88.

9.4.2 - REPLACING ELEMENTS SUBJECT TO WEAR AND ABRASION

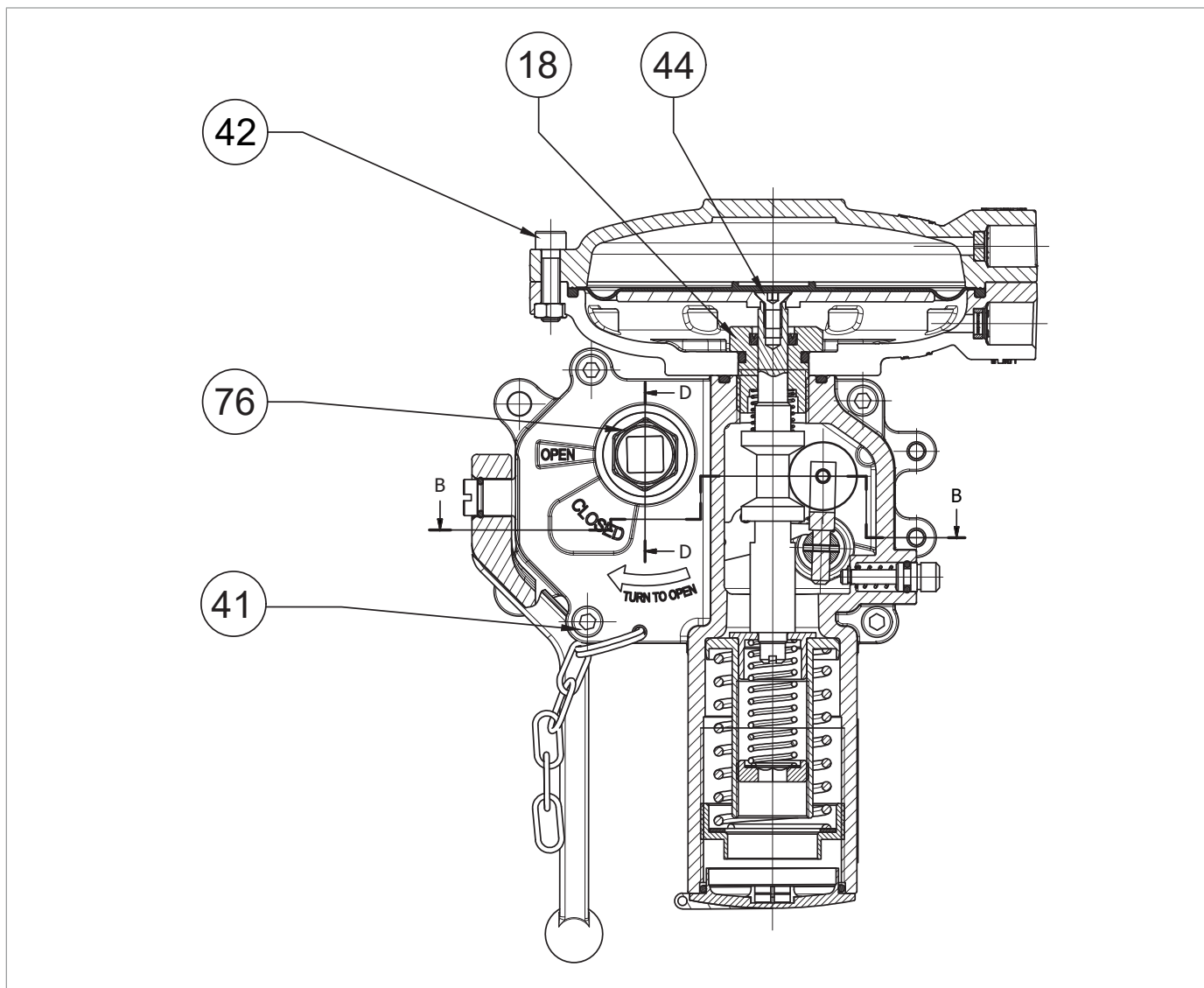
9.4.2.1 - INITIAL OPERATIONS

! ATTENTION!

Before carrying out any work, it is important to ensure that the line on which the regulator is installed has been shut off upstream and downstream, and discharged.

! ATTENTION!

During assembly, make sure to tighten the screws as per the tables (tightening torques), according to the size for which maintenance is being carried out.

Proceed as follows:

Step	Action
1	Unscrew the conical seal fittings to disconnect all power outlets and sensing lines for the pilot and regulator.
2	Loosen the nut securing the pilot support bracket to the regulator.

Tab. 9.89.

9.4.2.2 - CROSS DIAGRAM FOR TIGHTENING SCREWS

To tighten the screws, when required by the maintenance procedure, refer to the following diagram:

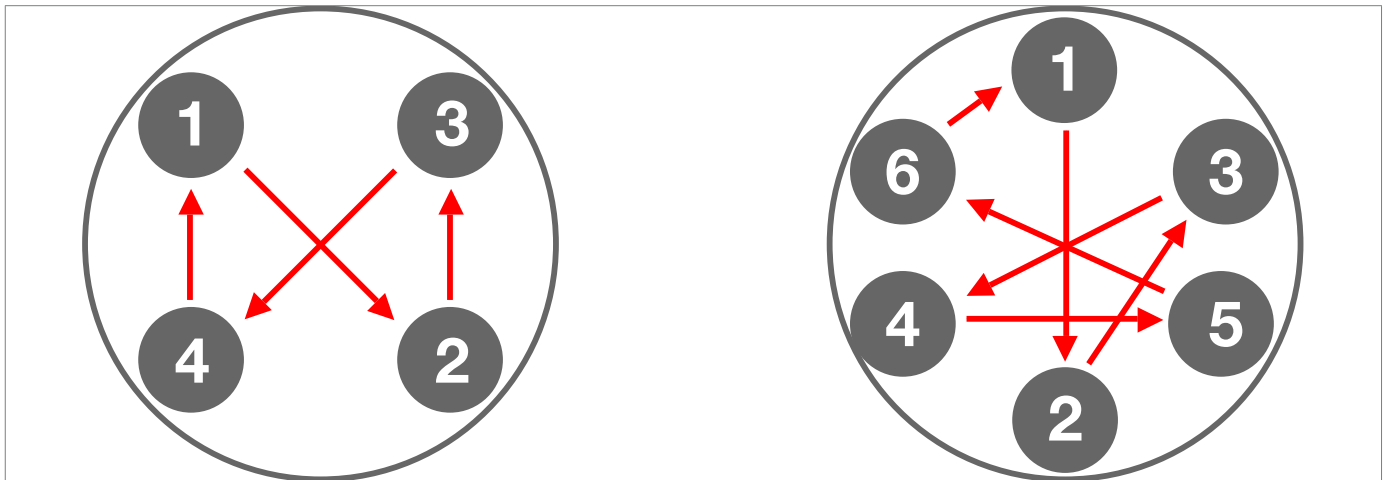

Fig. 9.32. Cross diagram

9.4.3 - ANTI-PUMPING VALVE MAINTENANCE

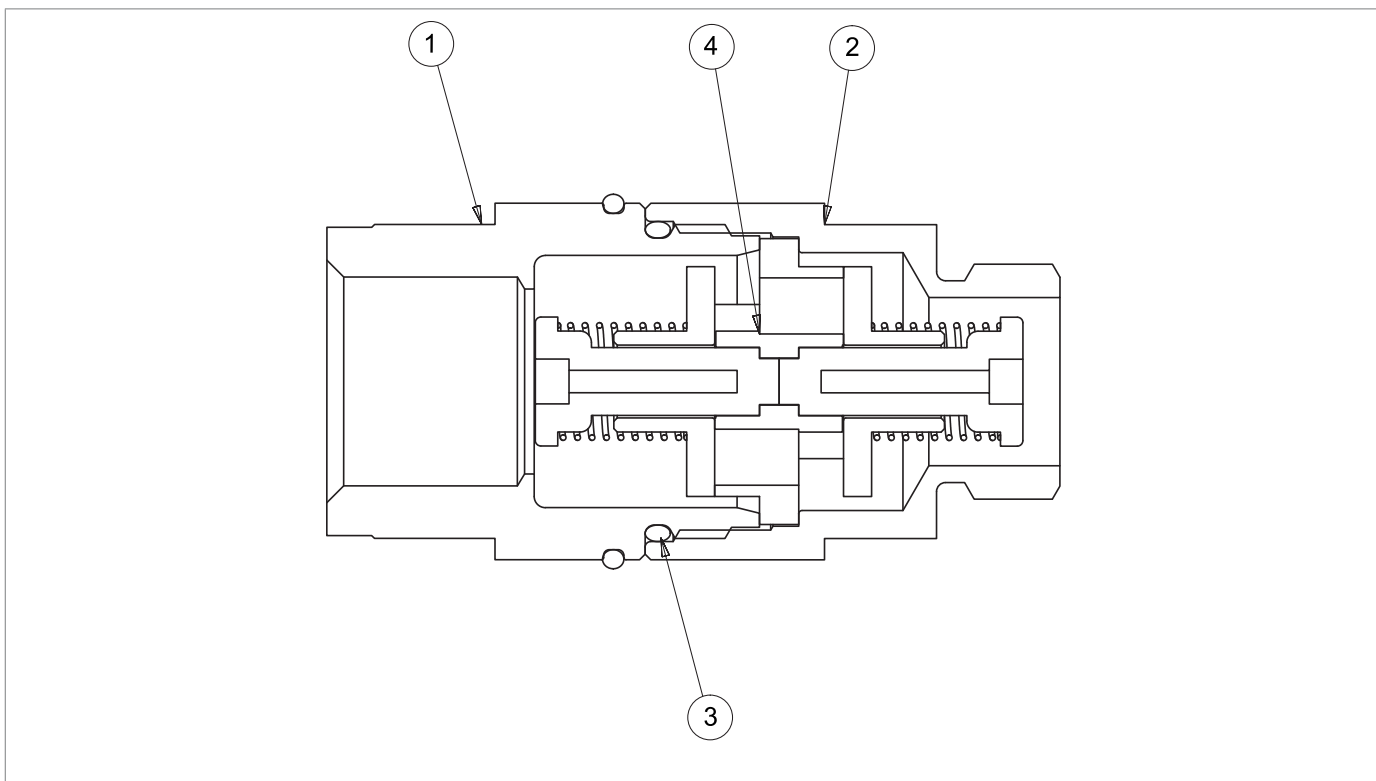

Fig. 9.33. Anti-pumping valve

Step	Action
1	Remove the fitting (1). NOTICE! During this stage, keep the body of the anti-pumping valve (2) still.
2	Remove the O-ring (3) and replace it, taking care to lubricate it with synthetic grease. NOTICE! Before inserting the replacement O-ring, clean the retaining slots with a cleaning solution.
3	Check that the plug assembly (4) is clean.
4	Put the fitting (1) in place and secure it. NOTICE! During this stage, keep the body of the anti-pumping valve (2) still.

Tab. 9.90.

9.4.4 - NORVAL REGULATOR

9.4.4.1 - NORVAL REGULATOR 1" - 2" (HEAD 375TR)

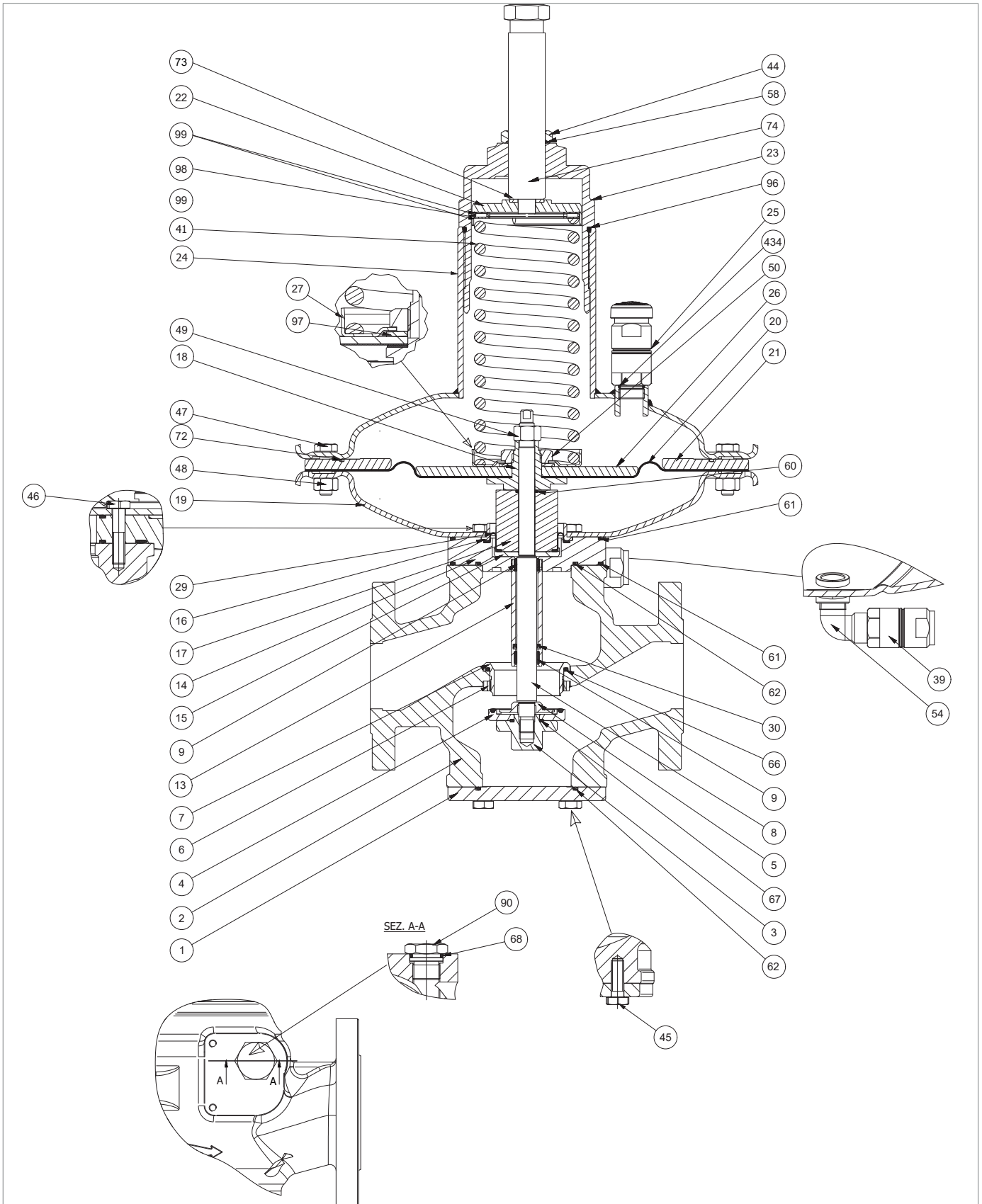
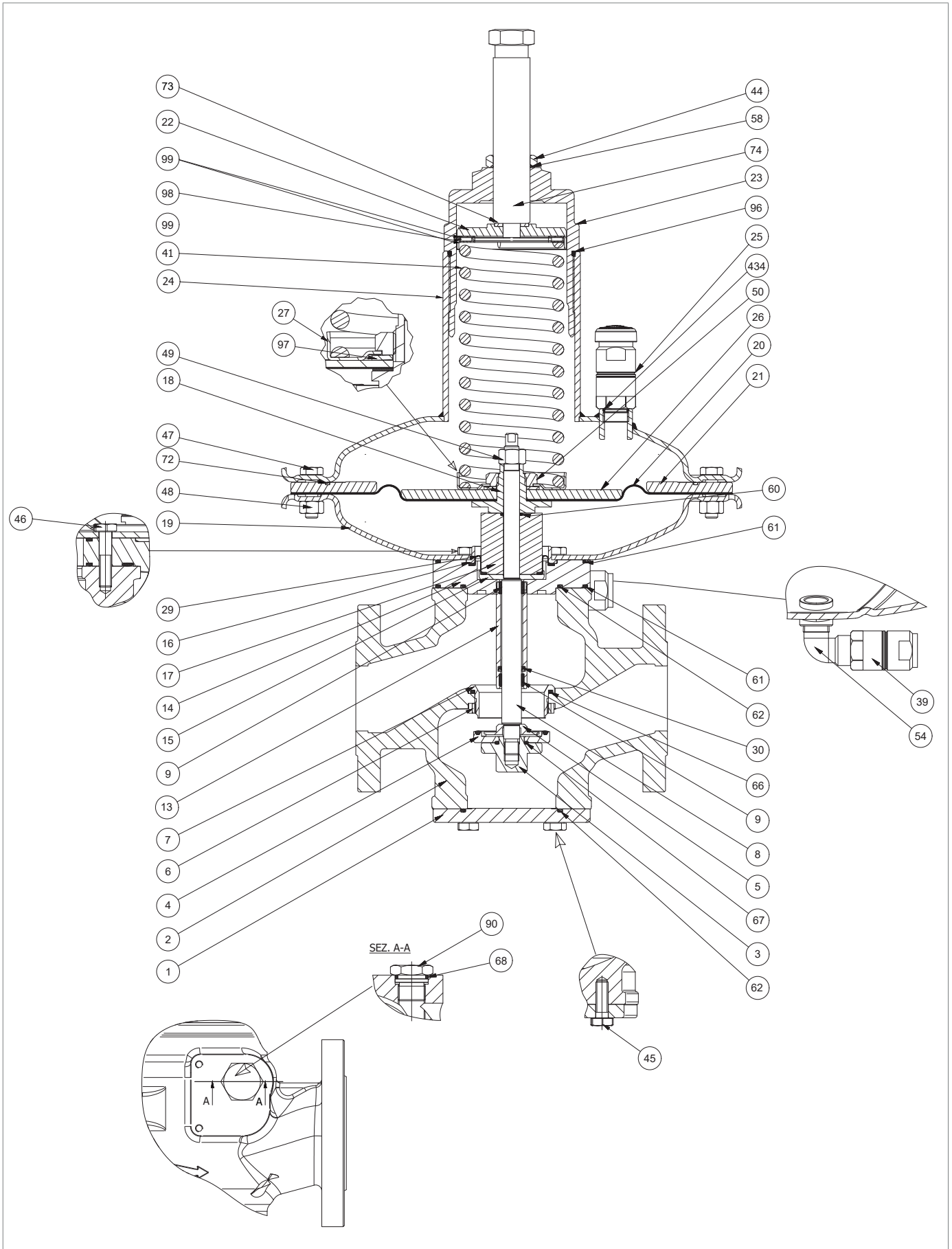

Fig. 9.34. NORVAL Regulator 1" - 2" (head 375TR)

Step	Action
1	Unscrew and remove the locking nut (44).
2	Undo and remove the adjustment screw (74).
3	Remove the O-ring (58) from the lock nut (44) and replace it, taking care to lubricate it with synthetic grease. <div style="border: 1px solid black; padding: 5px;">! NOTICE! Before inserting the replacement O-ring, clean the retaining slots with a cleaning solution.</div>
4	Unscrew and remove the cap (23).
5	Remove the O-ring (96) from the cap (23) and replace it, taking care to lubricate it with synthetic grease. <div style="border: 1px solid black; padding: 5px;">! NOTICE! Before inserting the replacement O-ring, clean the retaining slots with a cleaning solution.</div>
6	Remove the spring guide disc (22) together with the disc (73).
7	Remove the slewing rings (99) together with the roller bearing (98).
8	Remove the setting spring (41).
9	Unscrew and remove the anti-pumping valve (25) from the top cover (24).
10	Remove the O-ring (434) and replace it, taking care to lubricate it with synthetic grease. <div style="border: 1px solid black; padding: 5px;">! NOTICE! Before inserting the replacement O-ring, clean the retaining slots with a cleaning solution.</div>
11	Position and secure the anti-pumping valve (25) in the top cover (24).
12	Undo and remove the screws (45).
13	Remove the lower flange (1). <div style="background-color: yellow; padding: 5px;">! ATTENTION! In the presence of the ER device, refer to paragraph 9.4.5 for maintenance.</div>
14	Remove the O-ring (62) from the lower flange (1) and replace it, taking care to lubricate it with synthetic grease. <div style="border: 1px solid black; padding: 5px;">! NOTICE! Before inserting the replacement O-ring, clean the retaining slots with a cleaning solution.</div>
15	Unscrew and remove the gasket support (3) together with the reinforced gasket (4), the disc (5) and the O-ring (67) from the rod (8).
16	Remove the O-ring (67) from the gasket support (3) and replace it, taking care to lubricate it with synthetic grease. <div style="border: 1px solid black; padding: 5px;">! NOTICE! Before inserting the replacement O-ring, clean the retaining slots with a cleaning solution.</div>
17	Replace the reinforced gasket (4).
18	Undo and remove the nut (48) and the screw (47).
19	Remove the reduction disc (21).







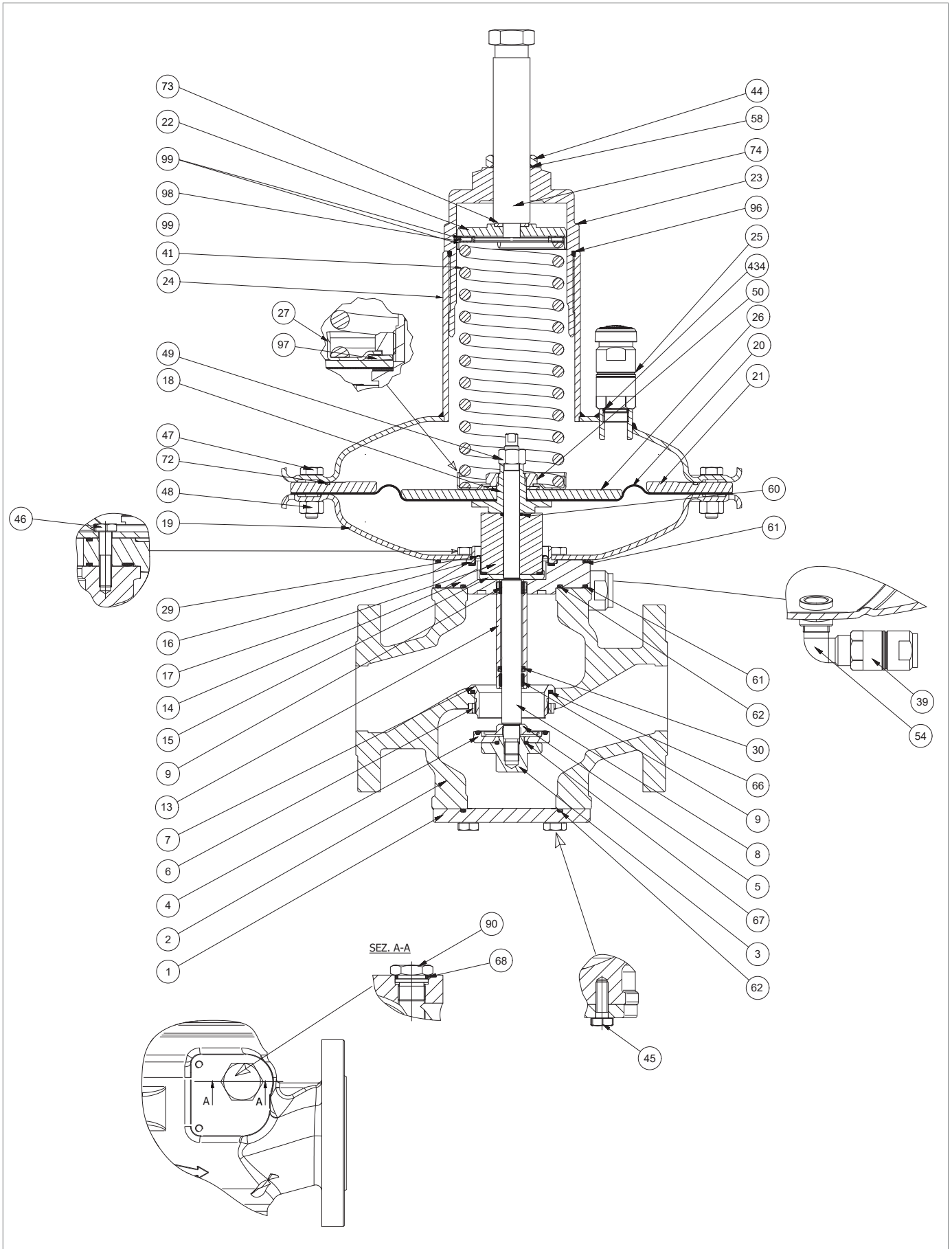



NORVAL Regulator 1" - 2" (head 375TR)

Step	Action
20	Remove the O-ring (72) from the reduction disc (21) and replace it, taking care to lubricate it with synthetic grease. NOTICE! Before inserting the replacement O-ring, clean the retaining slots with a cleaning solution.
21	Remove the top cover (24).
22	Unscrew and remove the nut (49). NOTICE! During this phase, keep the rod (8) still.
23	Remove the diaphragm assembly (18, 20, 26, 27, 50, 97) placing it on a shockproof surface.
24	Unscrew and remove the nut (50). NOTICE! During this phase, keep the diaphragm support (18) still.
25	Remove the spring guide (27).
26	Remove the spring (97).
27	Remove the diaphragm protection disc (26).
28	Remove and replace the diaphragm (20).
29	Fit the diaphragm (20).
30	Fit the diaphragm protection disc (26).
31	Fit the spring (97).
32	Fit the spring guide (27).
33	Insert and fix the nut (50) according to the following tightening torques: <ul style="list-style-type: none"> • 1: tab. 9.63 • 1 ½: tab. 9.64 • 2: tab. 9.65 NOTICE! During this phase, keep the diaphragm support (18) still.
34	Pull out the rod (8) from the top downwards.
35	Remove the spacer (17).
36	Remove the O-ring (60) from the spacer (17) and replace it, taking care to lubricate it with synthetic grease. NOTICE! Before inserting the replacement O-ring, clean the retaining slots with a cleaning solution.
37	Undo and remove the screws (46).
38	Remove the bottom cover (19) from the flange (14).
39	Remove the O-ring (61) and replace it, taking care to lubricate it with synthetic grease. NOTICE! Before inserting the replacement O-ring, clean the retaining slots with a cleaning solution.



NORVAL Regulator 1" - 2" (head 375TR)

Step	Action
40	Remove the bush (16).
41	Remove the balancing diaphragm (29) and replace it, taking care to lubricate it with synthetic grease.  NOTICE! Before inserting the replacement diaphragm, clean the retaining slots with a cleaning solution.
42	Remove the shaft collar (15).
43	Remove the flange (14) from the body (2) together with the rod guide sleeve (13).  ATTENTION! In the presence of the SN slam-shut valve, see paragraph 9.4.5 for maintenance.
44	Remove the I/DWR rings (9) from the rod guide sleeve (13) and replace them.  NOTICE! Before inserting the replacement I/DWR rings, clean the retaining slots with a cleaning solution.
45	Remove the lip seal (30) from the rod guide sleeve (13) and replace it.  NOTICE! <ul style="list-style-type: none"> • Before inserting the replacement seal, clean the retaining slots with a cleaning solution • Direct the gasket cavity towards the valve seat (7)
46	Remove the O-rings (61, 62) from the flange (14) and replace them, taking care to lubricate them with synthetic grease.  NOTICE! Before inserting the replacement O-rings, clean the retaining slots with a cleaning solution.
47	Undo and remove the locking ring nut (6).  NOTICE! Use the special spanner (O) in table 7.53 inserting it in the body (2).
48	Pull out the valve seat (7) from the bottom upwards.
49	Remove the O-rings (66) from the body (2) and replace them, taking care to lubricate them with synthetic grease.  NOTICE! Before inserting the replacement O-rings, clean the retaining slots with a cleaning solution.
50	Insert the valve seat (7) from the top downwards.
51	Insert the locking ring nut (6) and secure it according to the following tightening torques: <ul style="list-style-type: none"> • 1: tab. 9.63 • 1 ½: tab. 9.64 • 2: tab. 9.65  NOTICE! Use the special spanner (O) in table 7.53 inserting it in the body (2).

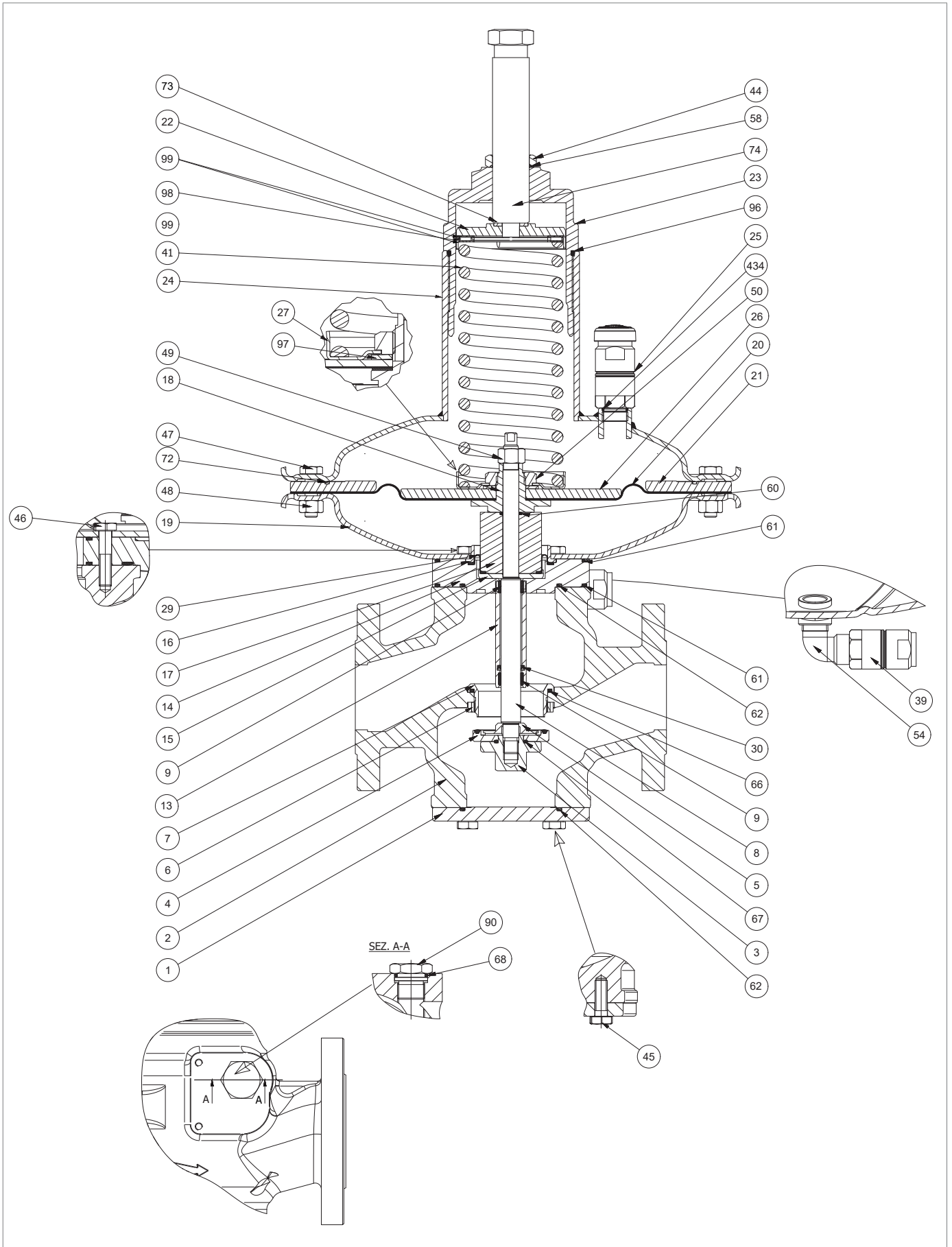



NORVAL Regulator 1" - 2" (head 375TR)

NORVAL

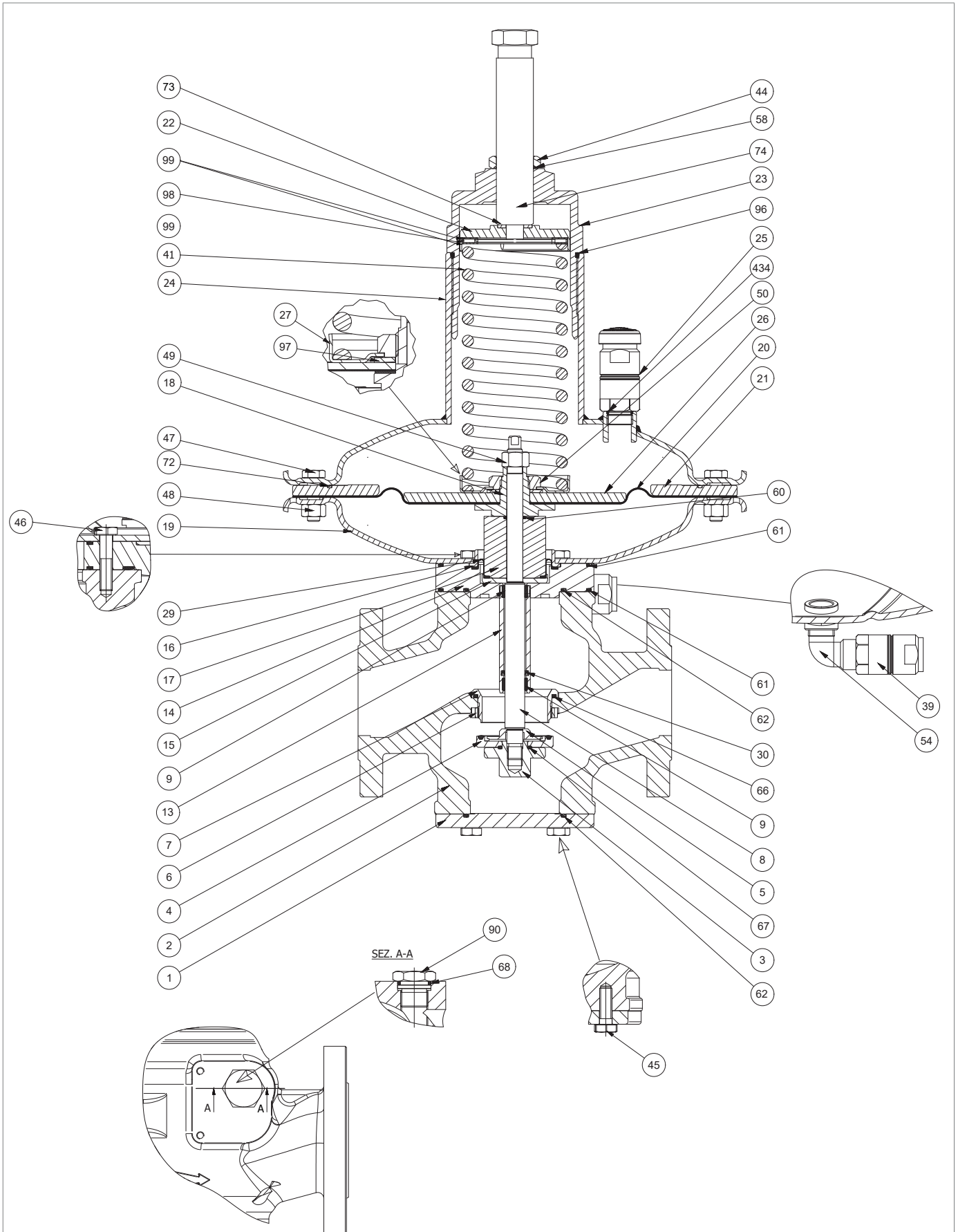
Step	Action
52	Insert the flange (14) into the body (2) together with the rod guide sleeve (13) and the O-rings (61, 62).
53	Fit the shaft collar (15).
54	Fit the balancing diaphragm (29).
55	Fit the bush (16).
56	Place the bottom cover (19) on the flange (14) together with the O-ring (61)
57	<p>Insert the screws (46) and secure them according to the following tightening torques:</p> <ul style="list-style-type: none"> • 1: tab. 9.63 • 1 ½: tab. 9.64 • 2: tab. 9.65 <p>NOTICE! Tighten the screws according to the cross diagram in paragraph 9.4.2.2.</p>
58	Position the spacer (17) together with the O-ring (60).
59	<p>Place the diaphragm assembly (18, 20, 26, 27, 50, 97) in the spacer (17).</p> <p>NOTICE! Centre the diaphragm support hole (18) in the hole of the spacer (17).</p>
60	<p>Insert the rod (8) into the body (2) from the bottom upwards.</p> <p>NOTICE!</p> <ul style="list-style-type: none"> • Align the hole of the spacer (17) to the diaphragm protection disc (26) • Clean and lubricate the rod (8)
61	<p>Insert the lock nut (49).</p> <p>NOTICE! Align the housing of the rod fixing spanner (8) and the housing of the diaphragm support fixing spanner (18).</p>
62	Align the holes of the main diaphragm (20) with the holes of the bottom cover (19).
63	<p>Secure the locking nut (49) according to the following tightening torques:</p> <ul style="list-style-type: none"> • 1: tab. 9.63 • 1 ½: tab. 9.64 • 2: tab. 9.65 <p>NOTICE! During this phase, keep the rod (8) and the diaphragm support (18) still.</p>
64	Position the reduction disc (21).
65	<p>Fit the top cover (24).</p> <p>NOTICE! Align the anti-pumping valve in the direction of the downstream flow.</p>
66	Insert the screws (47) into the top cover (24) and bottom cover (19).
67	Insert the nuts (48) into the screws (47).



NORVAL Regulator 1" - 2" (head 375TR)

Step	Action
68	Secure the screws (47) according to the following tightening torques: <ul style="list-style-type: none"> • 1: tab. 9.63 • 1 ½: tab. 9.64 • 2: tab. 9.65 <div style="border: 1px solid black; padding: 5px; margin-top: 10px;">  NOTICE! Tighten the screws according to the cross diagram in paragraph 9.4.2.2. </div>
69	Insert the setting spring (41).
70	Position the slewing rings (99) and roller bearings (98).
71	Insert the spring guide disc (22) together with the disc (73).
72	Insert and fix the cap (23).
73	Insert the adjustment screw (74) together with the O-ring (58) and the locking nut (44).
74	Fasten the locking nut (44).
75	Insert the gasket support (3) together with the reinforced gasket (4), the disc (5) and the O-ring (67) and secure them to the rod (8) according to the following tightening torques: <ul style="list-style-type: none"> • 1: tab. 9.63 • 1 ½: tab. 9.64 • 2: tab. 9.65
76	Fit the lower flange (1) together with the O-ring (62).
77	Insert and fix the screws (45) according to the following tightening torques: <ul style="list-style-type: none"> • 1: tab. 9.63 • 1 ½: tab. 9.64 • 2: tab. 9.65 <div style="border: 1px solid black; padding: 5px; margin-top: 10px;">  NOTICE! Tighten the screws according to the cross diagram in paragraph 9.4.2.2. </div>
78	Unscrew and remove the cap (90) from the front of the body (2).
79	Remove the O-ring (68) from the cap (90) and replace it, taking care to lubricate it with synthetic grease. <div style="border: 1px solid black; padding: 5px; margin-top: 10px;">  NOTICE! Before inserting the replacement O-ring, clean the retaining slots with a cleaning solution. </div>
80	Insert and fix the cap (90) in the front part of the body (2).

Tab. 9.91.

 **WARNING!**

Ensure that all parts have been fitted correctly.

9.4.4.2 - NORVAL REGULATOR 1" - 2" (HEAD 375)

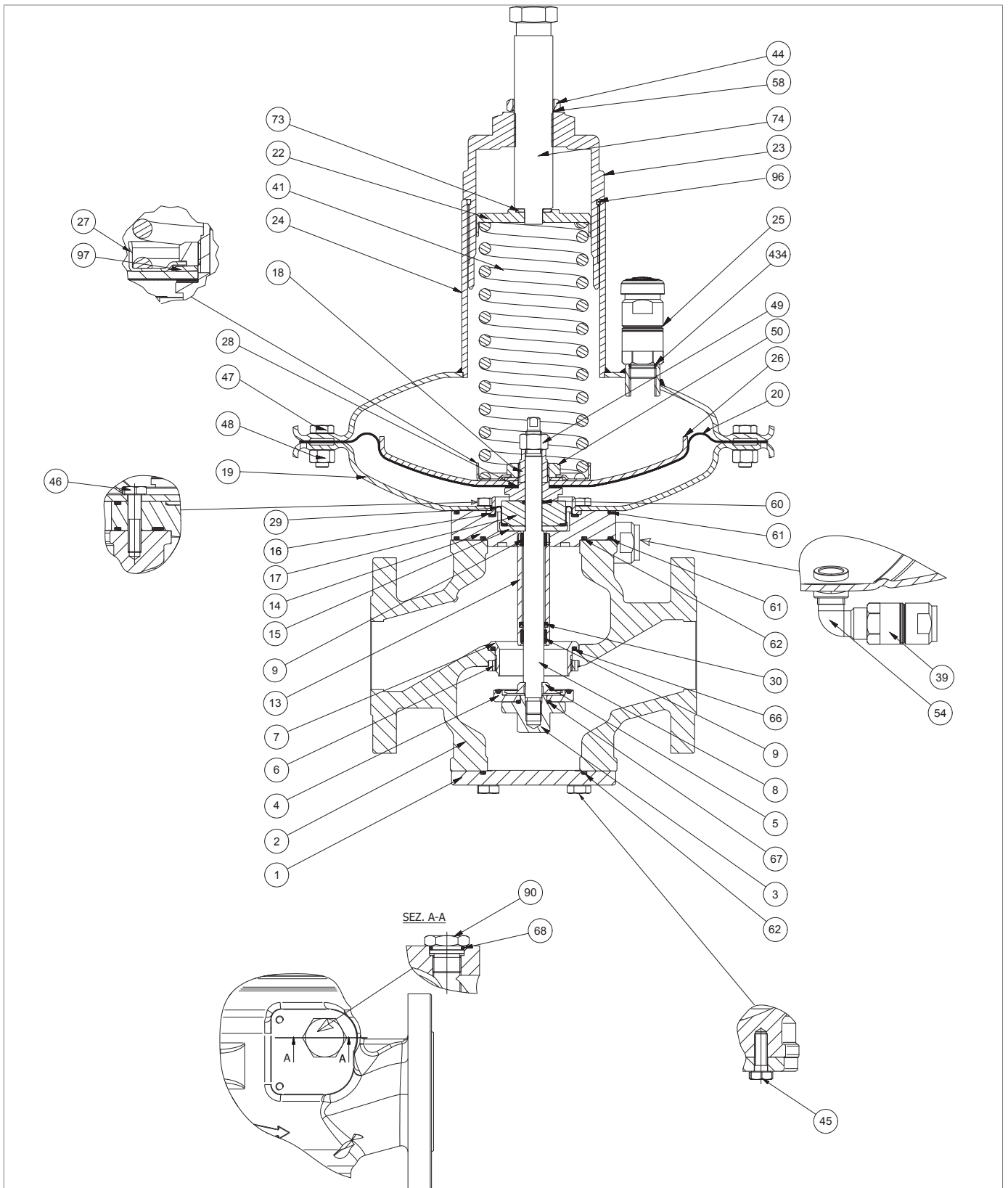
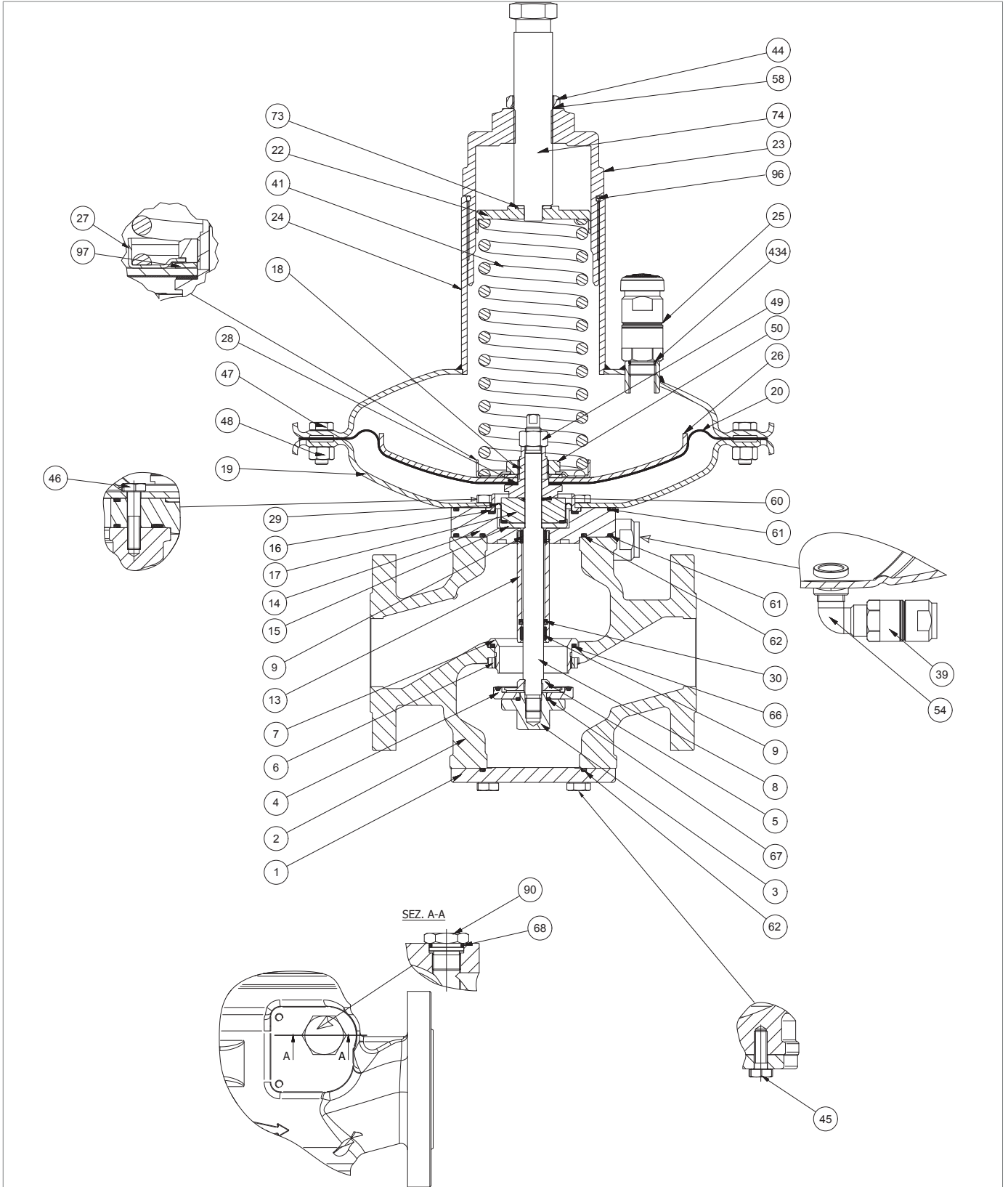







Fig. 9.35. NORVAL Regulator 1" - 2" (head 375)

Step	Action
1	Unscrew and remove the nut (44).
2	Undo and remove the adjustment screw (74).
3	Remove the O-ring (58) from the lock nut (44) and replace it, taking care to lubricate it with synthetic grease. ! NOTICE! Before inserting the replacement O-ring, clean the retaining slots with a cleaning solution.
4	Unscrew and remove the cap (23).
5	Remove the O-ring (96) from the cap (23) and replace it, taking care to lubricate it with synthetic grease. ! NOTICE! Before inserting the replacement O-ring, clean the retaining slots with a cleaning solution.
6	Remove the spring guide disc (22) together with the disc (73).
7	Remove the setting spring (41).
8	Unscrew and remove the anti-pumping valve (25) from the top cover (24).
9	Remove the O-ring (434) and replace it, taking care to lubricate it with synthetic grease. ! NOTICE! Before inserting the replacement O-ring, clean the retaining slots with a cleaning solution.
10	Position and secure the anti-pumping valve (25) in the top cover (24).
11	Undo and remove the screws (45).
12	Remove the lower flange (1). ! ATTENTION! In the presence of the ER device, refer to paragraph 9.4.5 for maintenance.
13	Remove the O-ring (62) from the lower flange (1) and replace it, taking care to lubricate it with synthetic grease. ! NOTICE! Before inserting the replacement O-ring, clean the retaining slots with a cleaning solution.
14	Unscrew and remove the gasket support (3) together with the reinforced gasket (4), the disc (5) and the O-ring (67) from the rod (8).
15	Remove the O-ring (67) from the gasket support (3) and replace it, taking care to lubricate it with synthetic grease. ! NOTICE! Before inserting the replacement O-ring, clean the retaining slots with a cleaning solution.
16	Replace the reinforced gasket (4).
17	Undo and remove the nut (48) and the screw (47).
18	Remove the top cover (24).
19	Unscrew and remove the nut (49). ! NOTICE! During this phase, keep the rod (8) and the diaphragm support (18) still.
20	Remove the diaphragm assembly (18, 20, 26, 27, 50, 97) placing it on a shockproof surface.



NORVAL Regulator 1'' - 2'' (head 375)

Step	Action
21	Unscrew and remove the nut (50).  NOTICE! During this phase, keep the diaphragm support (18) still.
22	Remove the spring guide (27).
23	Remove the spring (97).
24	Remove the diaphragm protection disc (26).
25	Remove and replace the diaphragm (20).
26	Fit the diaphragm (20).
27	Fit the diaphragm protection disc (26).
28	Fit the spring (97).
29	Fit the spring guide (27).
30	Insert and fix the nut (50) according to the following tightening torques: <ul style="list-style-type: none"> • 1: tab. 9.63 • 1 ½: tab. 9.64 • 2: tab. 9.65  NOTICE! During this phase, keep the diaphragm support (18) still.
31	Pull out the rod (8) from the top downwards.
32	Remove the spacer (17).
33	Remove the O-ring (60) from the spacer (17) and replace it, taking care to lubricate it with synthetic grease.  NOTICE! Before inserting the replacement O-ring, clean the retaining slots with a cleaning solution.
34	Undo and remove the screws (46).
35	Remove the bottom cover (19) from the flange (14).
36	Remove the O-ring (61) from the spacer (17) and replace it, taking care to lubricate it with synthetic grease.  NOTICE! Before inserting the replacement O-ring, clean the retaining slots with a cleaning solution.
37	Remove the bush (16).
38	Remove the balancing diaphragm (29) and replace it, taking care to lubricate it with synthetic grease.  NOTICE! Before inserting the replacement diaphragm, clean the retaining slots with a cleaning solution.
39	Remove the shaft collar (15).
40	Remove the flange (14) from the body (2) together with the rod guide sleeve (13).  ATTENTION! In the presence of the SN slam-shut valve, see paragraph 9.4.6 for maintenance.

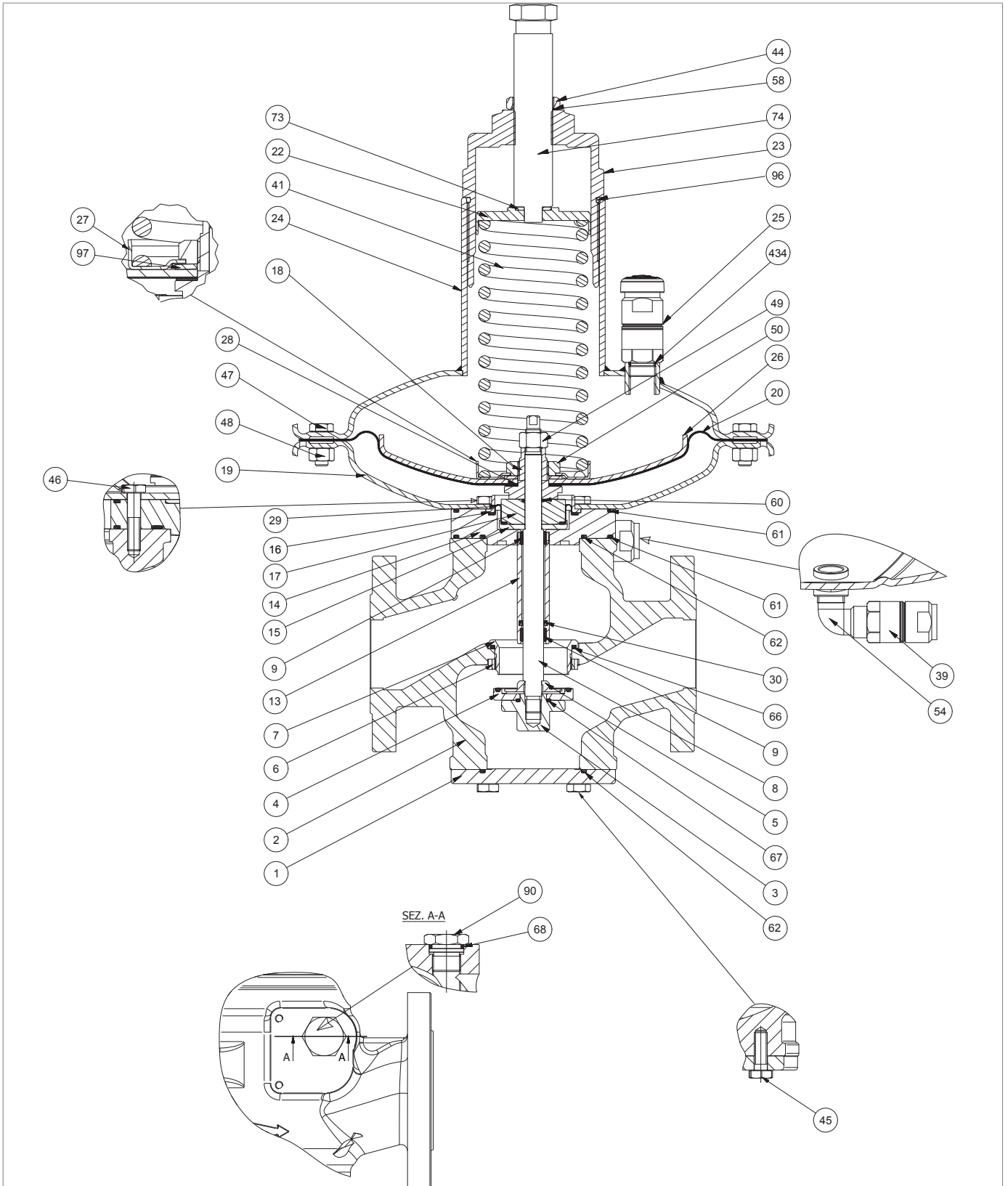

NORVAL Regulator 1'' - 2'' (head 375)

Step	Action
41	<p>Remove the I/DWR rings (9) from the rod guide sleeve (13) and replace them.</p> <p>! NOTICE!</p> <p>Before inserting the replacement I/DWR rings, clean the retaining slots with a cleaning solution.</p>
42	<p>Remove the lip seal (30) from the rod guide sleeve (13) and replace it.</p> <p>! NOTICE!</p> <ul style="list-style-type: none"> • Before inserting the replacement seal, clean the retaining slots with a cleaning solution • Direct the gasket cavity towards the valve seat (7)
43	<p>Remove the O-rings (61, 62) from the flange (14) and replace them, taking care to lubricate them with synthetic grease.</p> <p>! NOTICE!</p> <p>Before inserting the replacement O-rings, clean the retaining slots with a cleaning solution.</p>
44	<p>Undo and remove the locking ring nut (6).</p> <p>! NOTICE!</p> <p>Use the special spanner (O) in table 7.53 inserting it in the body (2).</p>
45	<p>Pull out the valve seat (7) from the bottom upwards.</p>
46	<p>Remove the O-rings (66) from the body (2) and replace them, taking care to lubricate them with synthetic grease.</p> <p>! NOTICE!</p> <p>Before inserting the replacement O-rings, clean the retaining slots with a cleaning solution.</p>
47	<p>Insert the valve seat (7) from the top downwards.</p>
48	<p>Insert the locking ring nut (6) and secure it according to the following tightening torques:</p> <ul style="list-style-type: none"> • 1: tab. 9.63 • 1 ½: tab. 9.64 • 2: tab. 9.65 <p>! NOTICE!</p> <p>Use the special spanner (O) in table 7.53 inserting it in the body (2).</p>
49	<p>Insert the flange (14) into the body (2) together with the rod guide sleeve (13) and the O-rings (61 lower, 62).</p>
50	<p>Fit the shaft collar (15).</p>
51	<p>Fit the balancing diaphragm (29).</p>
52	<p>Fit the bush (16).</p>
53	<p>Place the bottom cover (19) on the flange (14) together with the O-ring (61)</p>
54	<p>Insert the screws (46) and secure them according to the following tightening torques:</p> <ul style="list-style-type: none"> • 1: tab. 9.63 • 1 ½: tab. 9.64 • 2: tab. 9.65 <p>! NOTICE!</p> <p>Tighten the screws according to the cross diagram in paragraph 9.4.2.2.</p>

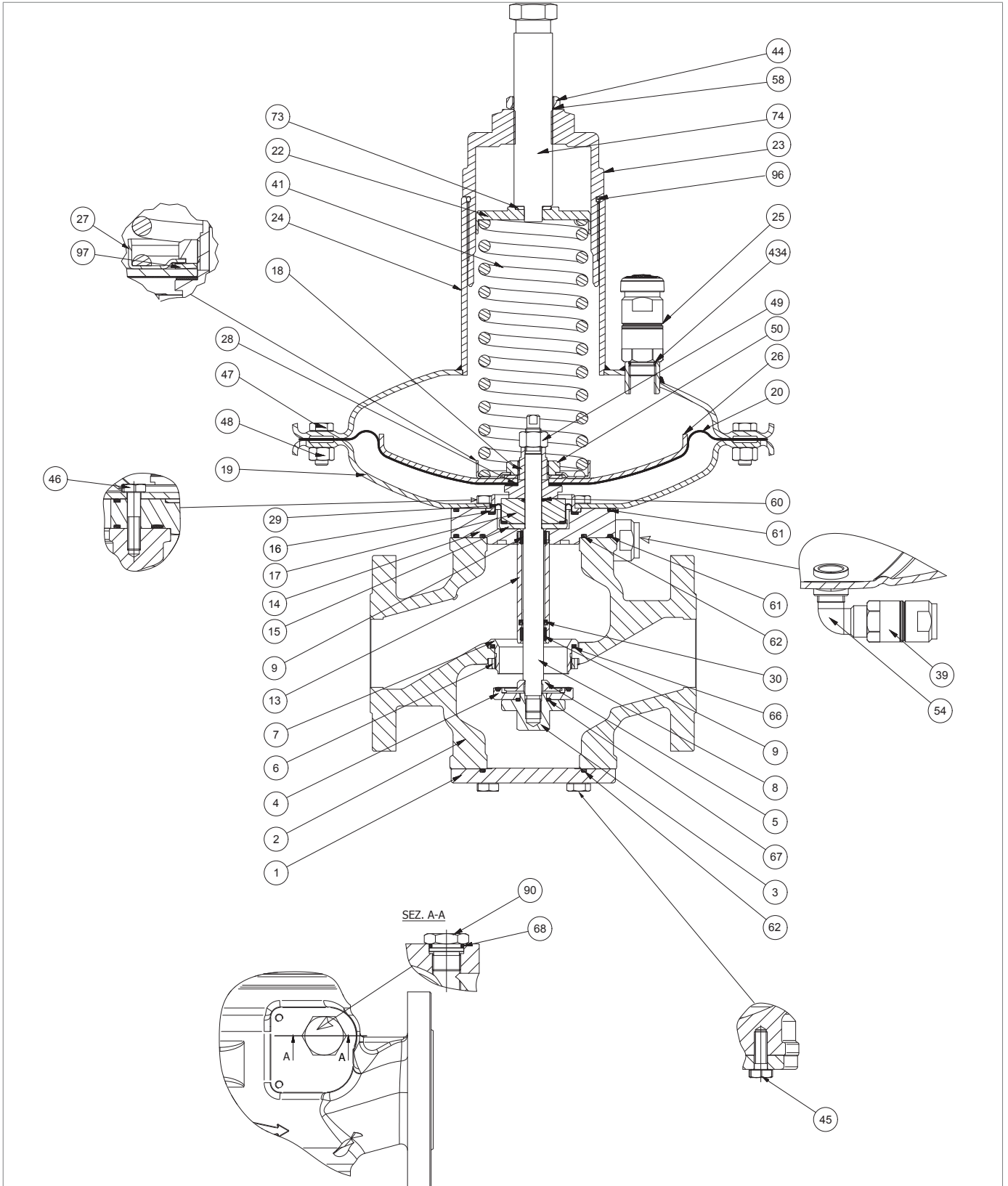

NORVAL Regulator 1" - 2" (head 375)

Step	Action
55	Position the spacer (17) together with the O-ring (60).
56	Place the diaphragm assembly (18, 20, 26, 27, 50, 97) in the spacer (17). ! NOTICE! Centre the diaphragm support hole (18) in the hole of the spacer (17).
57	Insert the rod (8) into the body (2) from the bottom upwards. ! NOTICE! <ul style="list-style-type: none"> • Align the hole of the spacer (17) to the diaphragm protection disc (26) • Clean and lubricate the rod (8)
58	Insert the lock nut (49). ! NOTICE! Align the housing of the rod fixing spanner (8) and the housing of the diaphragm support fixing spanner (18).
59	Align the holes of the main diaphragm (20) with the holes of the bottom cover (19).
60	Secure the locking nut (49) according to the following tightening torques: <ul style="list-style-type: none"> • 1: tab. 9.63 • 1 ½: tab. 9.64 • 2: tab. 9.65 ! NOTICE! During this phase, keep the rod (8) and the diaphragm support (18) still.
61	Fit the top cover (24). ! NOTICE! Align the anti-pumping valve (25) in the direction of the downstream flow.
62	Insert the screws (47) into the top cover (24) and bottom cover (19).
63	Insert the nuts (48) into the screws (47).
64	Secure the screws (47) according to the following tightening torques: <ul style="list-style-type: none"> • 1: tab. 9.63 • 1 ½: tab. 9.64 • 2: tab. 9.65 ! NOTICE! Tighten the screws according to the cross diagram in paragraph 9.4.2.2.
65	Insert the setting spring (41).
66	Insert the spring guide disc (22) together with the disc (73).
67	Insert and fix the cap (23).
68	Insert the adjustment screw (74) together with the O-ring (58) and the locking nut (44).
69	Insert and fasten the locking nut (44).
70	Insert the locking nut (3) together with the reinforced gasket (4), the disc (5) and the O-ring (67) and secure them to the rod (8) according to the following tightening torques: <ul style="list-style-type: none"> • 1: tab. 9.63 • 1 ½: tab. 9.64 • 2: tab. 9.65

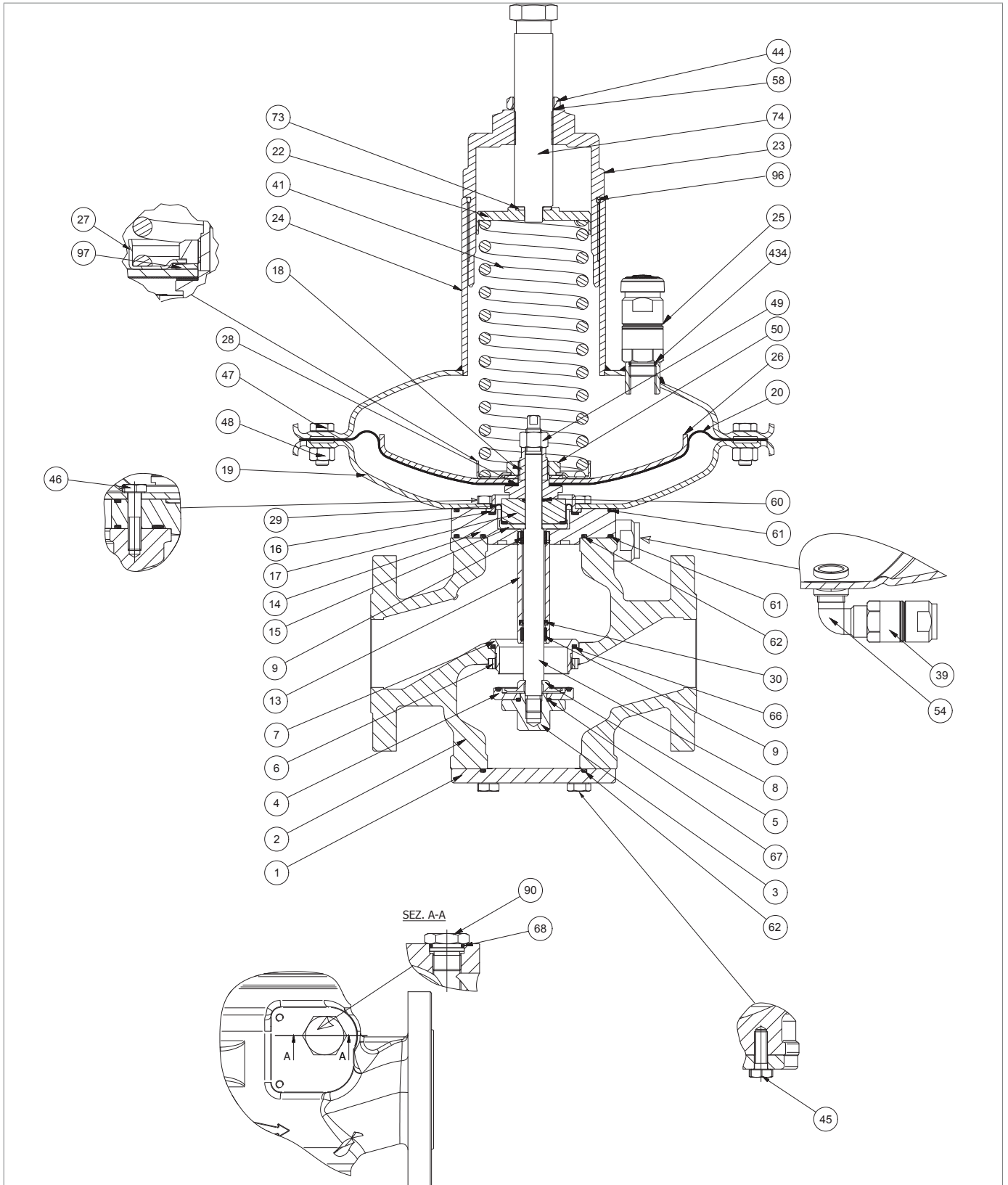

NORVAL Regulator 1" - 2" (head 375)

Step	Action
71	Fit the lower flange (1) together with the O-ring (62).
72	<p>Insert and fix the screws (45) according to the following tightening torques:</p> <ul style="list-style-type: none"> • 1: tab. 9.63 • 1 ½: tab. 9.64 • 2: tab. 9.65 <p>NOTICE! Tighten the screws according to the cross diagram in paragraph 9.4.2.2.</p>
73	Unscrew and remove the cap (90) from the front of the body (2).
74	<p>Remove the O-ring (68) from the cap (90) and replace it, taking care to lubricate it with synthetic grease.</p> <p>NOTICE! Before inserting the replacement O-ring, clean the retaining slots with a cleaning solution.</p>
75	Insert and fix the cap (90) in the front part of the body (2).

Tab. 9.92.

 **WARNING!**

Ensure that all parts have been fitted correctly.

9.4.4.3 - NORVAL REGULATOR 1" - 2" (HEAD 495)

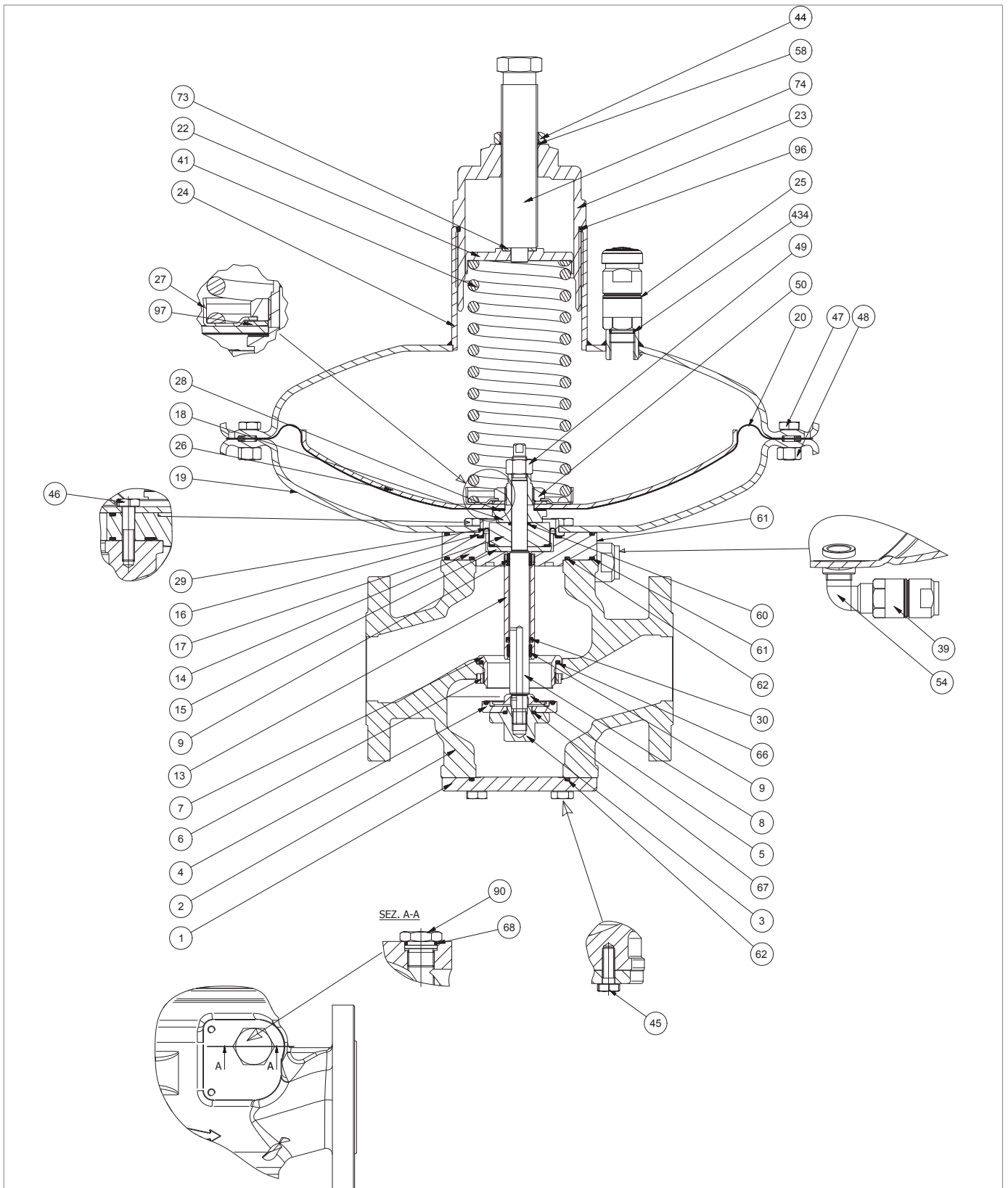
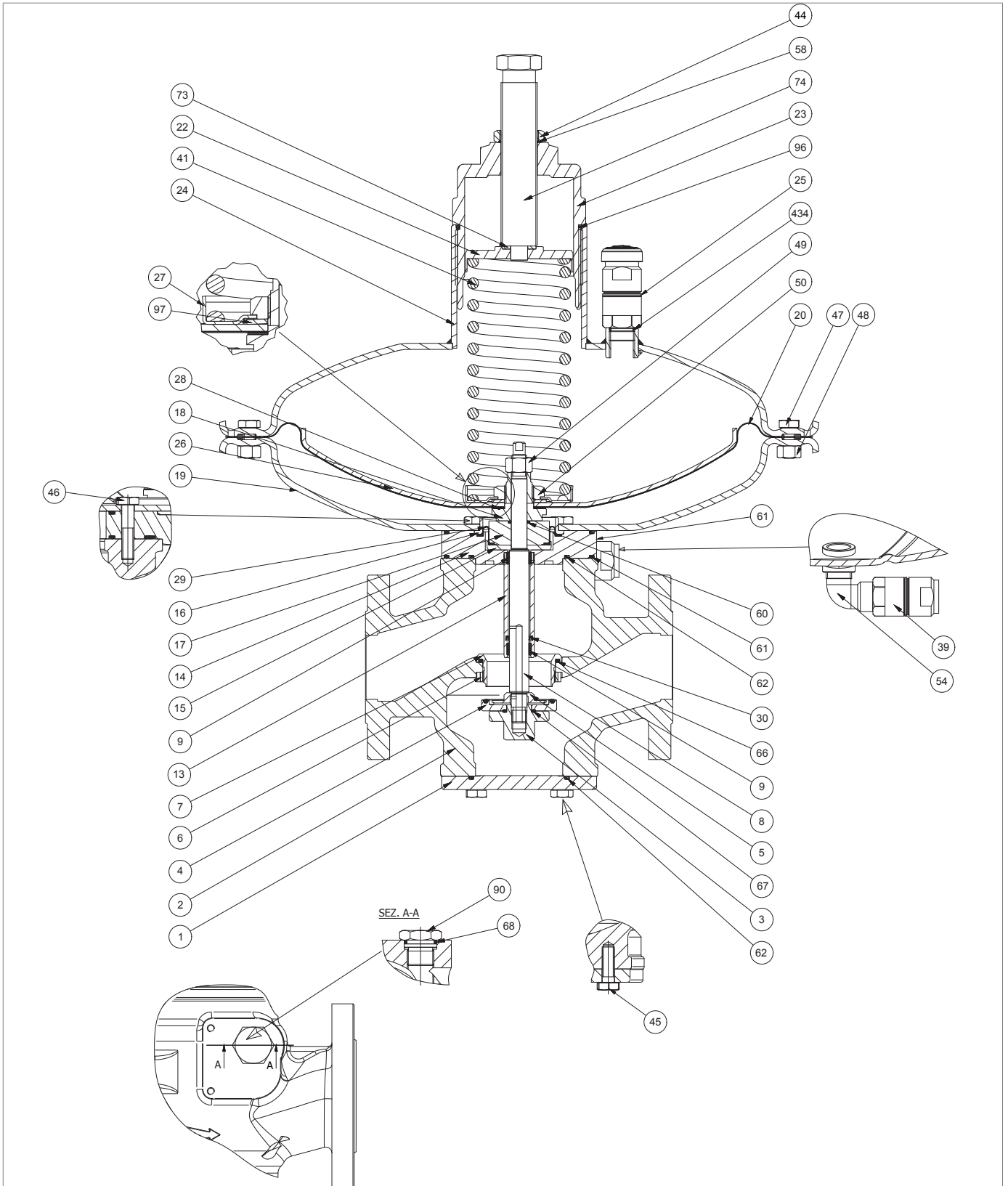

Fig. 9.36. NORVAL Regulator 1" - 2" (495)

Step	Action
1	Unscrew and remove the nut (44).
2	Undo and remove the adjustment screw (74).
3	Remove the O-ring (58) from the lock nut (44) and replace it, taking care to lubricate it with synthetic grease. <div style="border: 1px solid black; padding: 5px;">! NOTICE! Before inserting the replacement O-ring, clean the retaining slots with a cleaning solution.</div>
4	Unscrew and remove the cap (23).
5	Remove the O-ring (96) from the cap (23) and replace it, taking care to lubricate it with synthetic grease. <div style="border: 1px solid black; padding: 5px;">! NOTICE! Before inserting the replacement O-ring, clean the retaining slots with a cleaning solution.</div>
6	Remove the spring guide disc (22) together with the disc (73).
7	Remove the setting spring (41).
8	Unscrew and remove the anti-pumping valve (25) from the top cover (24).
9	Remove the O-ring (434) and replace it, taking care to lubricate it with synthetic grease. <div style="border: 1px solid black; padding: 5px;">! NOTICE! Before inserting the replacement O-ring, clean the retaining slots with a cleaning solution.</div>
10	Position and secure the anti-pumping valve (25) in the top cover (24).
11	Undo and remove the screws (45).
12	Remove the lower flange (1). <div style="background-color: yellow; padding: 5px;">! ATTENTION! In the presence of the ER device, refer to paragraph 9.4.5 for maintenance.</div>
13	Remove the O-ring (62) from the lower flange (1) and replace it, taking care to lubricate it with synthetic grease. <div style="border: 1px solid black; padding: 5px;">! NOTICE! Before inserting the replacement O-ring, clean the retaining slots with a cleaning solution.</div>
14	Unscrew locking nut (3) together with the reinforced gasket (4), the disc (5) and the O-ring (67) and remove them from the rod (8).
15	Remove the O-ring (67) from the locking nut (3) and replace it, taking care to lubricate it with synthetic grease. <div style="border: 1px solid black; padding: 5px;">! NOTICE! Before inserting the replacement O-ring, clean the retaining slots with a cleaning solution.</div>
16	Replace the reinforced gasket (4).
17	Undo and remove the nut (48) and the screw (47).
18	Remove the top cover (24).
19	Unscrew and remove the locking nut (49). <div style="border: 1px solid black; padding: 5px;">! NOTICE! During this phase, keep the rod (8) still.</div>



NORVAL Regulator 1" - 2" (495)

Step	Action
20	Remove the diaphragm assembly (18, 20, 26, 27, 28, 50, 97) placing it on a shockproof surface.
21	Unscrew and remove the nut (50). NOTICE! During this phase, keep the diaphragm support (18) still.
22	Remove the spring guide (27).
23	Remove the spring (97).
24	Remove the diaphragm protection disc (26).
25	Remove and replace the diaphragm (20).
26	Remove the oil seal (28) and replace it.
27	Fit the oil seal (28).
28	Fit the diaphragm (20).
29	Fit the diaphragm protection disc (26).
30	Fit the spring (97).
31	Fit the spring guide (27).
32	Insert and fix the nut (50) according to the following tightening torques: <ul style="list-style-type: none"> • 1: tab. 9.63 • 1 ½: tab. 9.64 • 2: tab. 9.65 NOTICE! During this phase, keep the diaphragm support (18) still.
33	Pull out the rod (8) from the top downwards.
34	Remove the spacer (17).
35	Remove the O-ring (60) from the spacer (17) and replace it, taking care to lubricate it with synthetic grease. NOTICE! Before inserting the replacement O-ring, clean the retaining slots with a cleaning solution.
36	Undo and remove the screws (46).
37	Remove the bottom cover (19) from the flange (14).
38	Remove the O-ring (61) from the spacer (17) and replace it, taking care to lubricate it with synthetic grease. NOTICE! Before inserting the replacement O-ring, clean the retaining slots with a cleaning solution.
39	Remove the bush (16).
40	Remove the balancing diaphragm (29) and replace it, taking care to lubricate it with synthetic grease. NOTICE! Before inserting the replacement diaphragm, clean the retaining slots with a cleaning solution.
41	Remove the shaft collar (15).

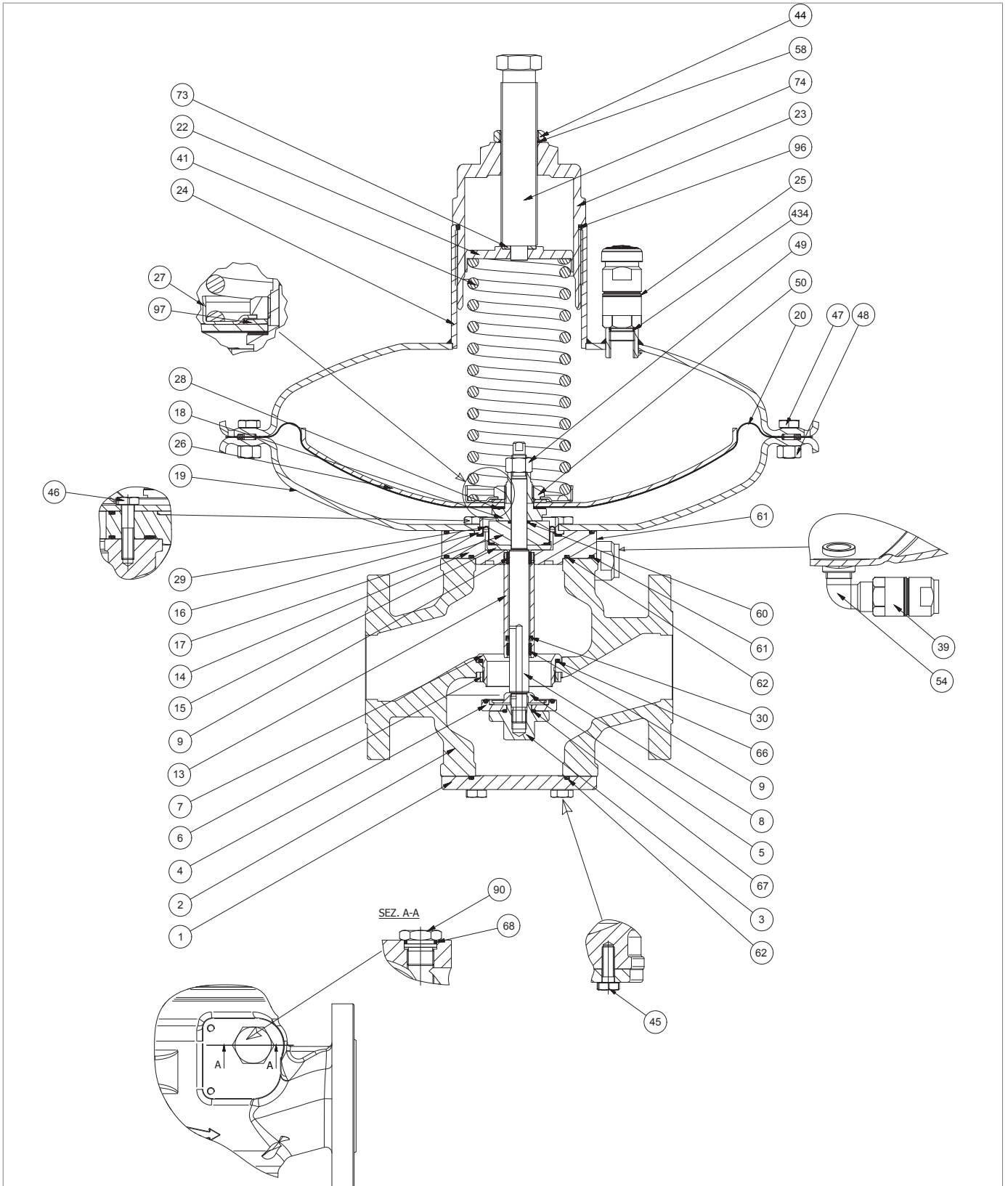

NORVAL Regulator 1" - 2" (495)

Step	Action
42	<p>Remove the flange (14) from the body (2) together with the rod guide sleeve (13).</p> <p>⚠ ATTENTION! In the presence of the SN slam-shut valve, see paragraph 9.4.6 for maintenance.</p>
43	<p>Remove the I/DWR rings (9) from the rod guide sleeve (13) and replace them.</p> <p>! NOTICE! Before inserting the replacement I/DWR rings, clean the retaining slots with a cleaning solution.</p>
44	<p>Remove the lip seal (30) from the rod guide sleeve (13) and replace it.</p> <p>! NOTICE!</p> <ul style="list-style-type: none"> • Before inserting the replacement seal, clean the retaining slots with a cleaning solution • Direct the gasket cavity towards the valve seat (7)
45	<p>Remove the O-rings (61, 62) from the flange (14) and replace them, taking care to lubricate them with synthetic grease.</p> <p>! NOTICE! Before inserting the replacement O-rings, clean the retaining slots with a cleaning solution.</p>
46	<p>Undo and remove the locking ring nut (6).</p> <p>! NOTICE! Use the special spanner (O) in table 7.53 inserting it in the body (2).</p>
47	<p>Pull out the valve seat (7) from the bottom upwards.</p>
48	<p>Remove the O-rings (66) from the body (2) and replace them, taking care to lubricate them with synthetic grease.</p> <p>! NOTICE! Before inserting the replacement O-rings, clean the retaining slots with a cleaning solution.</p>
49	<p>Insert the valve seat (7) from the top downwards.</p>
50	<p>Insert the locking ring nut (6) and secure it according to the following tightening torques:</p> <ul style="list-style-type: none"> • 1: tab. 9.63 • 1 ½: tab. 9.64 • 2: tab. 9.65 <p>! NOTICE! Use the special spanner (O) in table 7.53 inserting it in the body (2).</p>
51	<p>Insert the flange (14) into the body (2) together with the rod guide sleeve (13) and the O-rings (61, 62).</p>
52	<p>Fit the shaft collar (15).</p>
53	<p>Fit the balancing diaphragm (29).</p>
54	<p>Fit the bush (16).</p>
55	<p>Place the bottom cover (19) on the flange (14) together with the O-ring (61)</p>

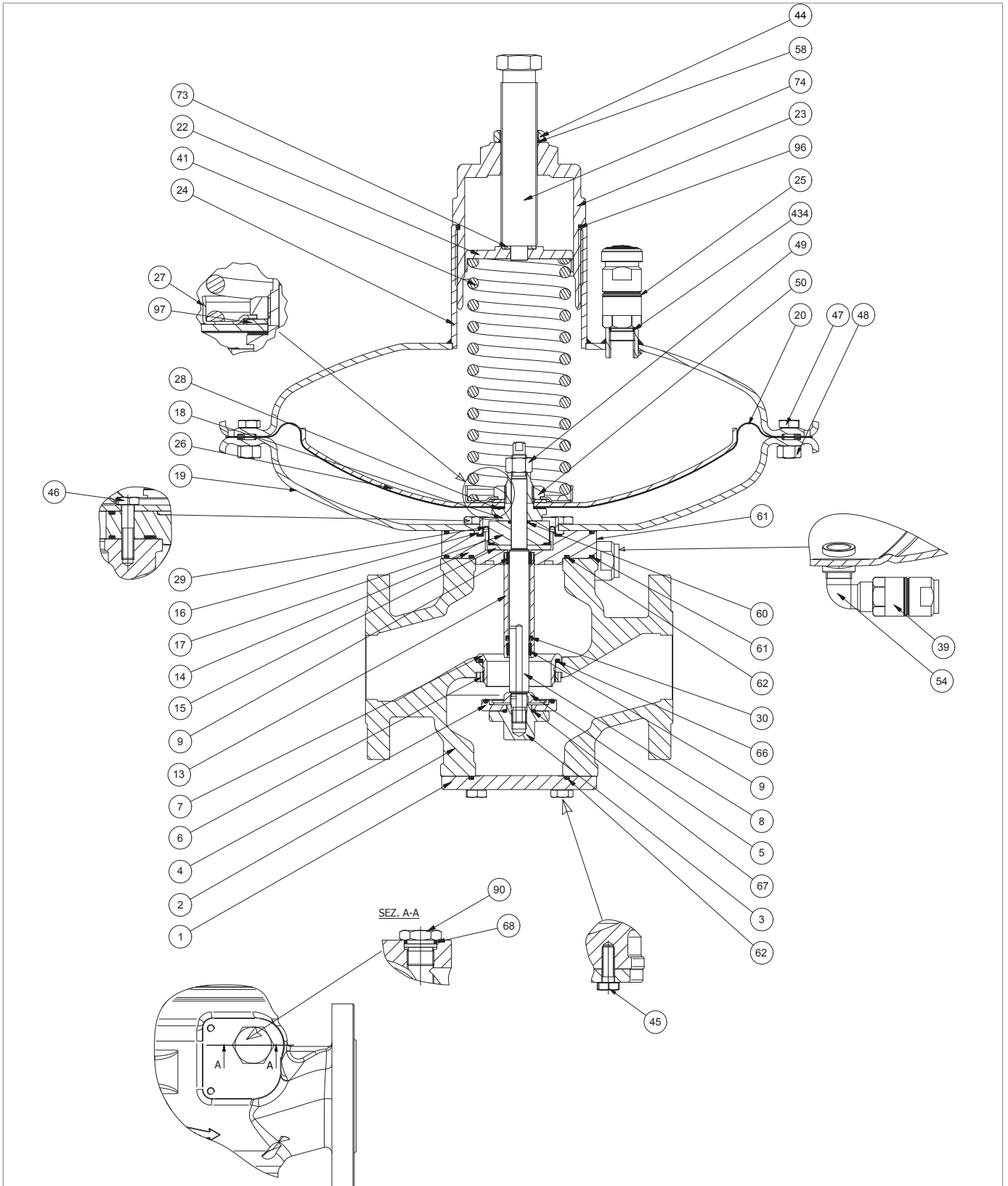

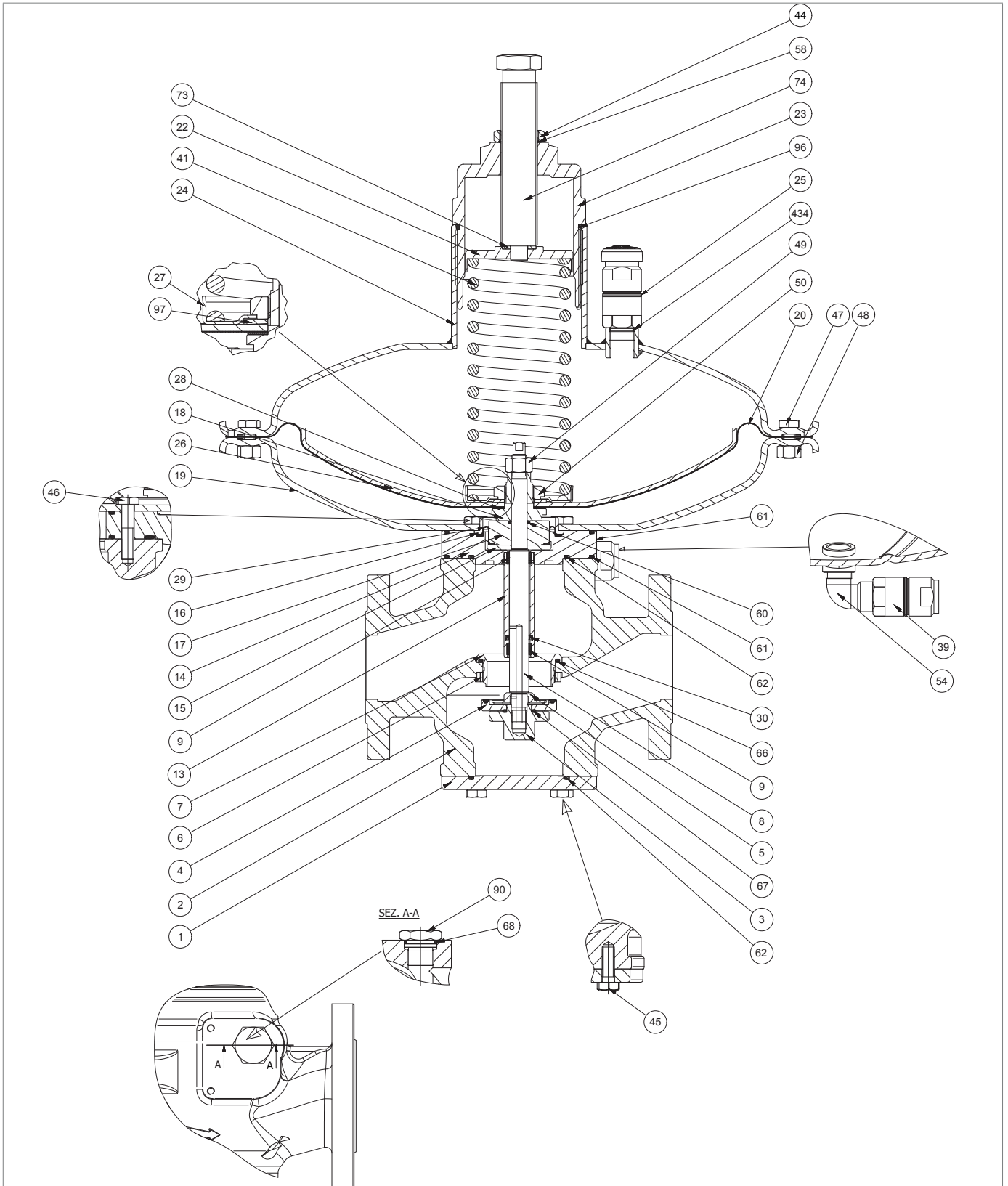

NORVAL Regulator 1" - 2" (495)

Step	Action
56	<p>Insert the screws (46) and secure them according to the following tightening torques:</p> <ul style="list-style-type: none"> • 1: tab. 9.63 • 1 ½: tab. 9.64 • 2: tab. 9.65 <div style="border: 1px solid black; padding: 5px;"> <p>! NOTICE!</p> <p>Tighten the screws according to the cross diagram in paragraph 9.4.2.2.</p> </div>
57	Position the spacer (17) together with the O-ring (60).
58	<p>Place the diaphragm assembly (18, 20, 26, 27, 28, 50, 97) in the spacer (17).</p> <div style="border: 1px solid black; padding: 5px;"> <p>! NOTICE!</p> <p>Centre the diaphragm support hole (18) in the hole of the spacer (17).</p> </div>
59	<p>Insert the rod (8) into the body (2) from the bottom upwards.</p> <div style="border: 1px solid black; padding: 5px;"> <p>! NOTICE!</p> <ul style="list-style-type: none"> • Align the hole of the spacer (17) to the diaphragm protection disc (26) • Clean and lubricate the rod (8) </div>
60	<p>Insert the lock nut (49).</p> <div style="border: 1px solid black; padding: 5px;"> <p>! NOTICE!</p> <p>Align the housing of the rod fixing spanner (8) and the housing of the diaphragm support fixing spanner (18).</p> </div>
61	Align the holes of the main diaphragm (20) with the holes of the bottom cover (19).
62	<p>Secure the locking nut (49) according to the following tightening torques:</p> <ul style="list-style-type: none"> • 1: tab. 9.63 • 1 ½: tab. 9.64 • 2: tab. 9.65 <div style="border: 1px solid black; padding: 5px;"> <p>! NOTICE!</p> <p>During this phase, keep the rod (8) and the diaphragm support (18) still.</p> </div>
63	<p>Fit the top cover (24).</p> <div style="border: 1px solid black; padding: 5px;"> <p>! NOTICE!</p> <p>Align the anti-pumping valve (25) in the direction of the downstream flow.</p> </div>
64	Insert the screws (47) into the top cover (24) and bottom cover (19).
65	Insert the nuts (48) into the screws (47).
66	<p>Secure the screws (47) according to the following tightening torques:</p> <ul style="list-style-type: none"> • 1: tab. 9.63 • 1 ½: tab. 9.64 • 2: tab. 9.65 <div style="border: 1px solid black; padding: 5px;"> <p>! NOTICE!</p> <p>Tighten the screws according to the cross diagram in paragraph 9.4.2.2.</p> </div>
67	Insert the setting spring (41).
68	Insert the spring guide disc (22) together with the disc (73).



NORVAL Regulator 1" - 2" (495)

Step	Action
69	Insert and fix the cap (23).
70	Insert the adjustment screw (74) together with the O-ring (58) and the locking nut (44).
71	Insert and fasten the locking nut (44).
72	Insert the locking nut (3) together with the O-ring (67), the reinforced gasket (4) and the disc (5) and secure them to the rod (8) according to the following tightening torques: <ul style="list-style-type: none"> • 1: tab. 9.63 • 1 ½: tab. 9.64 • 2: tab. 9.65
73	Fit the lower flange (1) together with the O-ring (62).
74	Insert and fix the screws (45) according to the following tightening torques: <ul style="list-style-type: none"> • 1: tab. 9.63 • 1 ½: tab. 9.64 • 2: tab. 9.65 <div style="border: 1px solid blue; padding: 5px; margin-top: 5px;">  NOTICE! Tighten the screws according to the cross diagram in paragraph 9.4.2.2. </div>
75	Unscrew and remove the cap (90) from the front of the body (2).
76	Remove the O-ring (68) from the cap (90) and replace it, taking care to lubricate it with synthetic grease. <div style="border: 1px solid blue; padding: 5px; margin-top: 5px;">  NOTICE! Before inserting the replacement O-ring, clean the retaining slots with a cleaning solution. </div>
77	Insert and fix the cap (90) in the front part of the body (2).

Tab. 9.93.

 **WARNING!**

Ensure that all parts have been fitted correctly.

9.4.4.4 - NORVAL REGULATOR 2" 1/2 - 3" (HEAD 375TR)

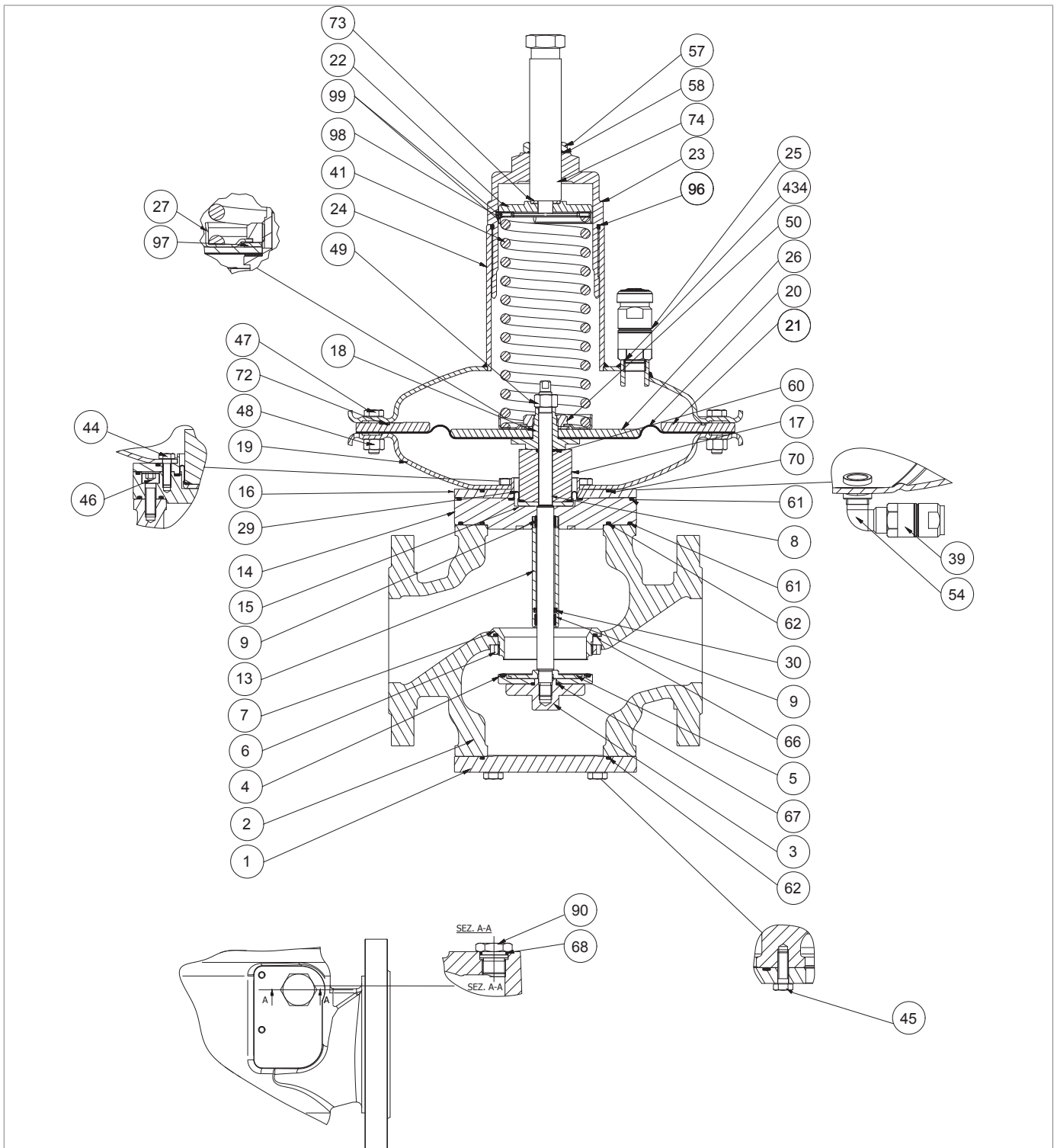





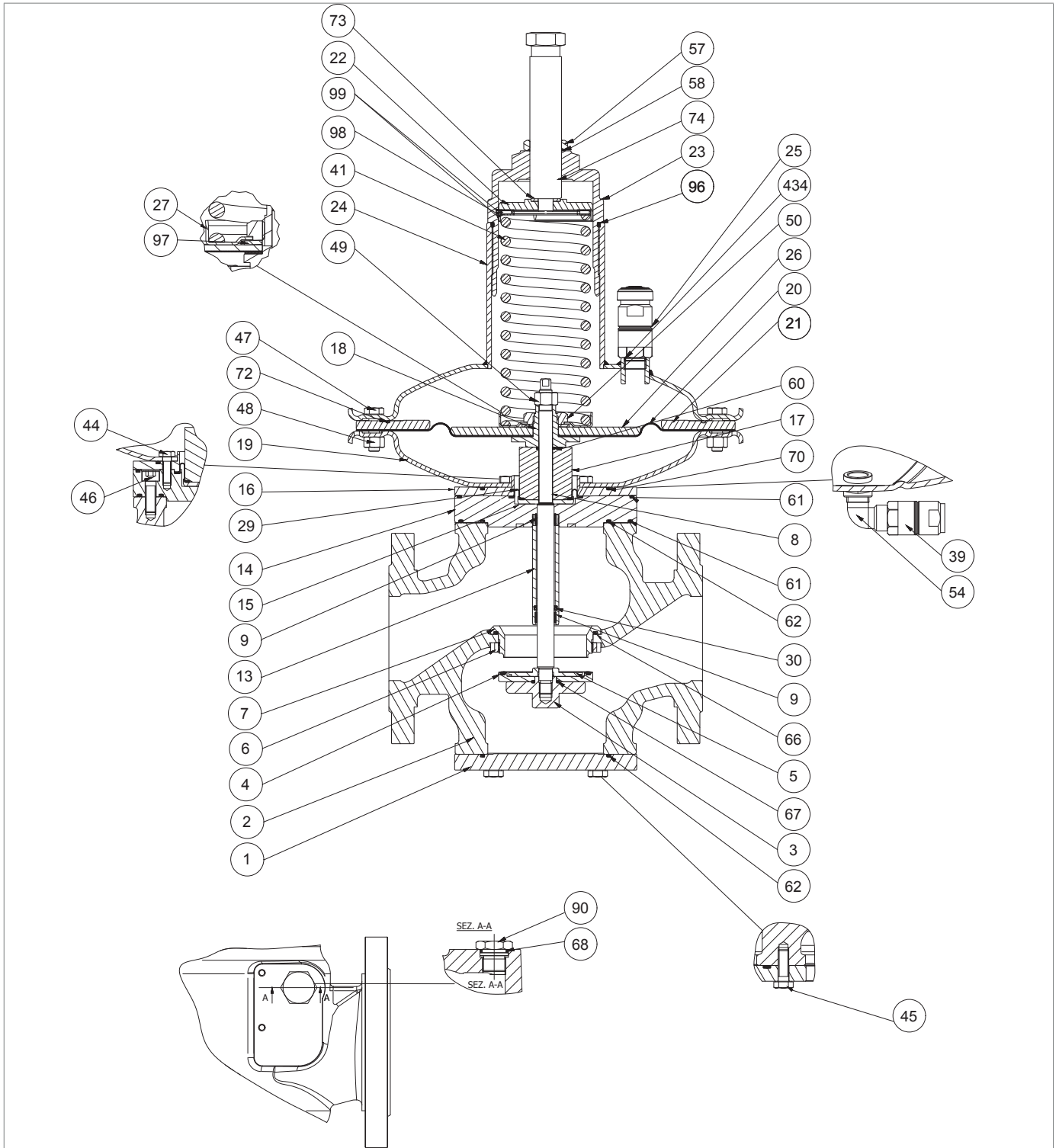

Fig. 9.37. NORVAL Regulator 2" 1/2 - 3" (head 375TR)

Step	Action
1	Unscrew and remove the locking nut (57).
2	Undo and remove the adjustment screw (74).
3	Remove the O-ring (58) from the lock nut (44) and replace it, taking care to lubricate it with synthetic grease. <div style="border: 1px solid black; padding: 5px;">  NOTICE! Before inserting the replacement O-ring, clean the retaining slots with a cleaning solution. </div>
4	Unscrew and remove the cap (23).
5	Remove the O-ring (96) from the cap (23) and replace it, taking care to lubricate it with synthetic grease. <div style="border: 1px solid black; padding: 5px;">  NOTICE! Before inserting the replacement O-ring, clean the retaining slots with a cleaning solution. </div>
6	Remove the spring guide disc (22) together with the disc (73).
7	Remove the slewing rings (99) together with the roller bearing (98).
8	Remove the setting spring (41).
9	Unscrew and remove the anti-pumping valve (25) from the top cover (24).
10	Remove the O-ring (434) and replace it, taking care to lubricate it with synthetic grease. <div style="border: 1px solid black; padding: 5px;">  NOTICE! Before inserting the replacement O-ring, clean the retaining slots with a cleaning solution. </div>
11	Position and secure the anti-pumping valve (25) in the top cover (24).
12	Undo and remove the screws (45).
13	Remove the lower flange (1). <div style="background-color: yellow; padding: 5px;">  ATTENTION! In the presence of the ER device, refer to paragraph 9.4.5 for maintenance. </div>
14	Remove the O-ring (62) from the lower flange (1) and replace it, taking care to lubricate it with synthetic grease. <div style="border: 1px solid black; padding: 5px;">  NOTICE! Before inserting the replacement O-ring, clean the retaining slots with a cleaning solution. </div>
15	Unscrew locking nut (3) together with the reinforced gasket (4), the disc (5) and the O-ring (67) and remove them from the rod (8).
16	Remove the O-ring (67) from the locking nut (3) and replace it, taking care to lubricate it with synthetic grease. <div style="border: 1px solid black; padding: 5px;">  NOTICE! Before inserting the replacement O-ring, clean the retaining slots with a cleaning solution. </div>
17	Replace the reinforced gasket (4).
18	Undo and remove the nut (48) and the screw (47).
19	Remove the top cover (24).
20	Remove the reduction disc (21).



NORVAL Regulator 2" 1/2 - 3" (head 375TR)

Step	Action
21	Remove the O-ring (72) from the reduction disc (21) and replace it, taking care to lubricate it with synthetic grease. NOTICE! Before inserting the replacement O-ring, clean the retaining slots with a cleaning solution.
22	Unscrew and remove the locking nut (49). NOTICE! During this phase, keep the rod (8) still.
23	Remove the diaphragm assembly (18, 20, 26, 27, 28, 50, 97) placing it on a shockproof surface.
24	Unscrew and remove the nut (50). NOTICE! During this phase, keep the diaphragm support (18) still.
25	Remove the spring guide (27).
26	Remove the spring (97).
27	Remove the diaphragm protection disc (26).
28	Remove the diaphragm (20).
29	Fit the diaphragm (20).
30	Fit the diaphragm protection disc (26).
31	Fit the spring (97).
32	Fit the spring guide (27).
33	Insert and fix the nut (50) according to the following tightening torques: <ul style="list-style-type: none"> 2" 1/2: tab. 9.66 3": tab. 9.68 NOTICE! During this phase, keep the diaphragm support (18) still.
34	Pull out the rod (8) from the top downwards.
35	Remove the spacer (17).
36	Remove the O-ring (60) from the spacer (17) and replace it, taking care to lubricate it with synthetic grease. NOTICE! Before inserting the replacement O-ring, clean the retaining slots with a cleaning solution.
37	Undo and remove the screws (44).
38	Remove the bottom cover (19) from the bush (16))
39	Remove the O-ring (70) from the bush (16) and replace it, taking care to lubricate it with synthetic grease. NOTICE! Before inserting the replacement O-ring, clean the retaining slots with a cleaning solution.
40	Remove the bush (16).

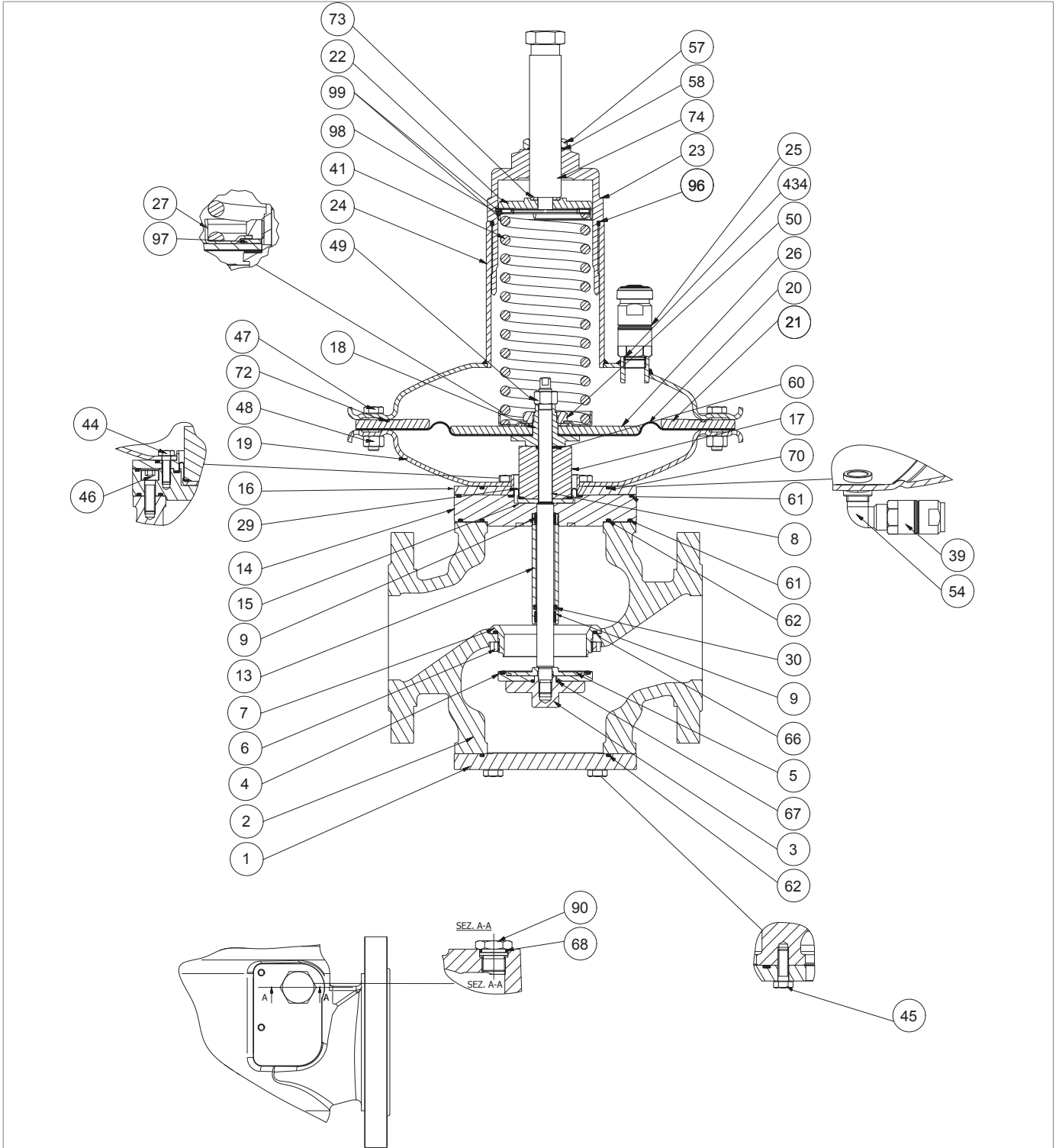





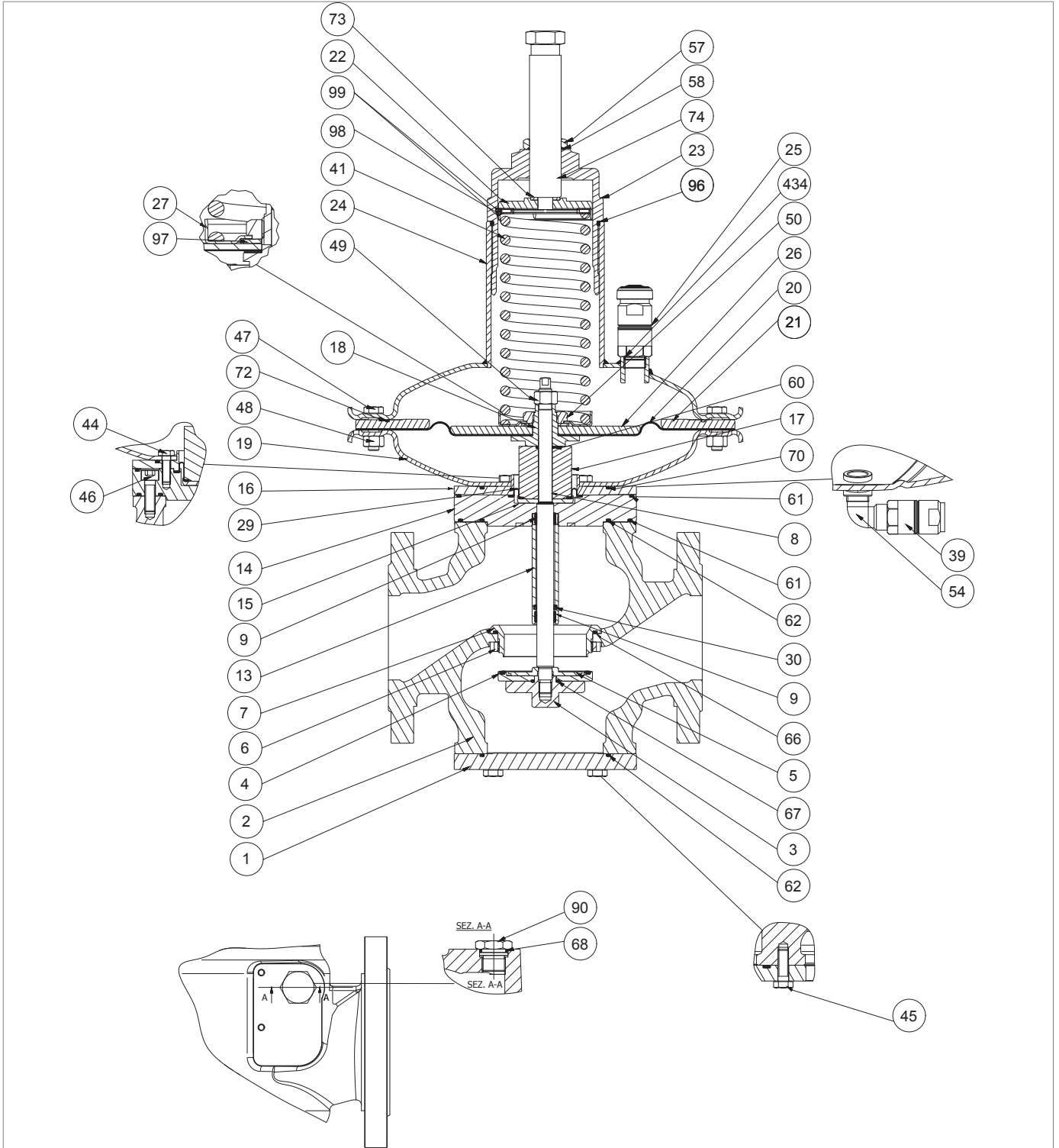

NORVAL Regulator 2" 1/2 - 3" (head 375TR)

Step	Action
41	<p>Remove the balancing diaphragm (29) and replace it, taking care to lubricate it with synthetic grease.</p> <p>! NOTICE!</p> <p>Before inserting the replacement diaphragm, clean the retaining slots with a cleaning solution.</p>
42	<p>Remove the O-ring (61) from the flange (14) and replace it, taking care to lubricate it with synthetic grease.</p> <p>! NOTICE!</p> <p>Before inserting the replacement O-ring, clean the retaining slots with a cleaning solution.</p>
43	<p>Undo and remove the screws (46).</p>
44	<p>! ATTENTION!</p> <p>In the presence of the SN slam-shut valve, see paragraph 9.4.6 for maintenance.</p>
45	<p>Remove the shaft collar (15).</p>
46	<p>Remove the I/DWR ring (9) from the rod guide (13) and replace it.</p> <p>! NOTICE!</p> <p>Before inserting the replacement I/DWR ring, clean the retaining slots with a cleaning solution.</p>
47	<p>Remove the lip seal (30) from the rod guide sleeve (13) and replace it.</p> <p>! NOTICE!</p> <ul style="list-style-type: none"> • Before inserting the replacement seal, clean the retaining slots with a cleaning solution • Direct the gasket cavity towards the valve seat (7)
48	<p>Remove the O-rings (61, 62) from the flange (14) and replace them, taking care to lubricate them with synthetic grease.</p> <p>! NOTICE!</p> <p>Before inserting the replacement O-rings, clean the retaining slots with a cleaning solution.</p>
49	<p>Undo and remove the locking ring nut (6) in the body (2).</p> <p>! NOTICE!</p> <p>Use the special spanner (O) in table 7.53 inserting it in the body (2).</p>
50	<p>Pull out the valve seat (7) from the bottom upwards.</p>
51	<p>Remove the O-ring (66) from the body (2) and replace it, taking care to lubricate them with synthetic grease.</p> <p>! NOTICE!</p> <p>Before inserting the replacement O-ring, clean the retaining slots with a cleaning solution.</p>
52	<p>Insert the valve seat (7) from the top downwards.</p>
53	<p>Insert the locking ring nut (6) and secure it according to the following tightening torques:</p> <ul style="list-style-type: none"> • 2" 1/2: tab. 9.66 • 3": tab. 9.68 <p>! NOTICE!</p> <p>Use the special spanner (O) in table 7.53 inserting it in the body (2).</p>



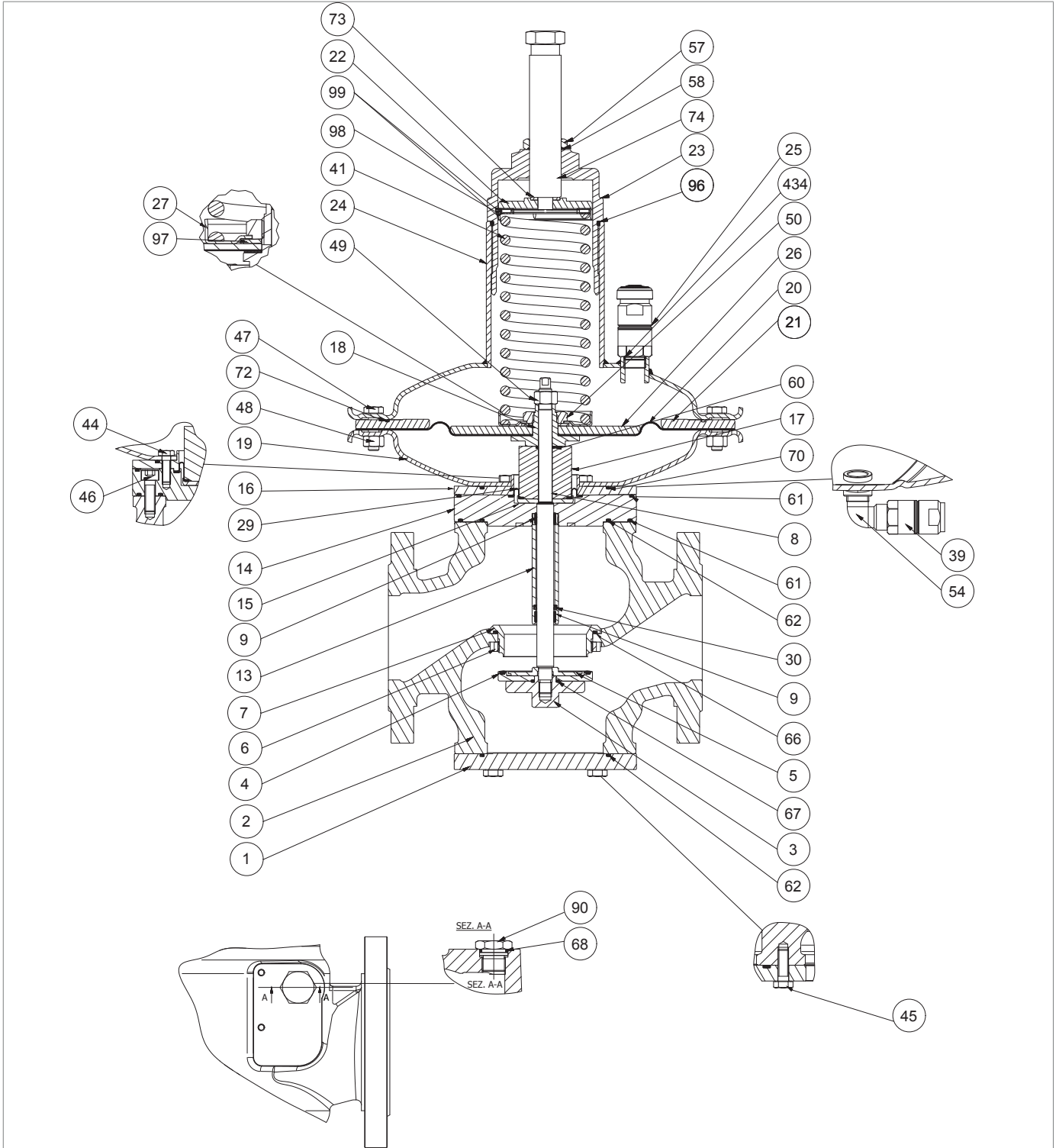

NORVAL Regulator 2" 1/2 - 3" (head 375TR)

Step	Action
54	Insert the flange (14) into the body (2) together with the rod guide sleeve (13) and the O-rings (61 lower, 62).
55	Insert and fix the screws (46) according to the following tightening torques: <ul style="list-style-type: none"> • 2" 1/2: tab. 9.66 • 3": tab. 9.68 <div style="border: 1px solid black; padding: 5px;">  NOTICE! Tighten the screws according to the cross diagram in paragraph 9.4.2.2. </div>
56	Fit the shaft collar (15).
57	Fit the balancing diaphragm (29).
58	Fit the bush (16).
60	Fit the bottom cover (19) into the bush (16).
61	Insert and fix the screws (44) according to the following tightening torques: <ul style="list-style-type: none"> • 2" 1/2: tab. 9.66 • 3": tab. 9.68 <div style="border: 1px solid black; padding: 5px;">  NOTICE! Tighten the screws according to the cross diagram in paragraph 9.4.2.2. </div>
62	Position the spacer (17) together with the O-ring (60).
63	Place the diaphragm assembly (18, 20, 26, 27, 28, 50, 97) in the spacer (17). <div style="border: 1px solid black; padding: 5px;">  NOTICE! Centre the diaphragm support hole (18) in the hole of the spacer (17). </div>
64	Insert the rod (8) into the body (2) from the bottom upwards. <div style="border: 1px solid black; padding: 5px;">  NOTICE! <ul style="list-style-type: none"> • Align the hole of the spacer (17) to the diaphragm protection disc (26) • Clean and lubricate the rod (8) </div>
65	Insert the lock nut (49). <div style="border: 1px solid black; padding: 5px;">  NOTICE! Align the housing of the rod fixing spanner (8) and the housing of the diaphragm support fixing spanner (18). </div>
66	Align the holes of the main diaphragm (20) with the holes of the bottom cover (19).
67	Secure the locking nut (49) according to the following tightening torques: <ul style="list-style-type: none"> • 2" 1/2: tab. 9.66 • 3": tab. 9.68 <div style="border: 1px solid black; padding: 5px;">  NOTICE! During this phase, keep the rod (8) and the diaphragm support (18) still. </div>
68	Position the reduction disc (21) together with the O-ring (72).
69	Fit the top cover (24). <div style="border: 1px solid black; padding: 5px;">  NOTICE! Align the anti-pumping valve (25) in the direction of the downstream flow. </div>



NORVAL Regulator 2" 1/2 - 3" (head 375TR)

Step	Action
70	Insert the screws (47) into the top cover (24) and bottom cover (19).
71	Insert the nuts (48) into the screws (47).
72	Secure the screws (47) according to the following tightening torques: <ul style="list-style-type: none"> • 2" 1/2: tab. 9.66 • 3": tab. 9.68 <div style="border: 1px solid black; padding: 5px; margin-top: 5px;">  NOTICE! Tighten the screws according to the cross diagram in paragraph 9.4.2.2. </div>
73	Insert the setting spring (41).
74	Position the slewing rings (98) and roller bearings (99).
75	Insert the spring guide disc (22) together with the disc (73).
76	Insert and fix the cap (23).
77	Insert the adjustment screw (74) together with the O-ring (58) and the locking nut (44).
78	Insert and fasten the locking nut (57)
79	Insert the locking nut (3) together with the reinforced gasket (4), the disc (5) and the O-ring (67) and secure them to the rod (8) from the bottom upwards, according to the following tightening torques: <ul style="list-style-type: none"> • 2" 1/2: tab. 9.66 • 3": tab. 9.68
80	Fit the lower flange (1) together with the O-ring (62).
81	Insert and fix the screws (45) according to the following tightening torques: <ul style="list-style-type: none"> • 2" 1/2: tab. 9.66 • 3": tab. 9.68 <div style="border: 1px solid black; padding: 5px; margin-top: 5px;">  NOTICE! Tighten the screws according to the cross diagram in paragraph 9.4.2.2. </div>
82	Unscrew and remove the cap (90) together with the O-ring (68) from the front of the body (2).
83	Remove the O-ring (68) from the cap (90) and replace it, taking care to lubricate it with synthetic grease. <div style="border: 1px solid black; padding: 5px; margin-top: 5px;">  NOTICE! Before inserting the replacement O-ring, clean the retaining slots with a cleaning solution. </div>
84	Position the cap (90) in the body (2).

Tab. 9.94.

 **WARNING!**

Ensure that all parts have been fitted correctly.

9.4.4.5 - NORVAL REGULATOR 2" 1/2 - 3" (HEAD 375)

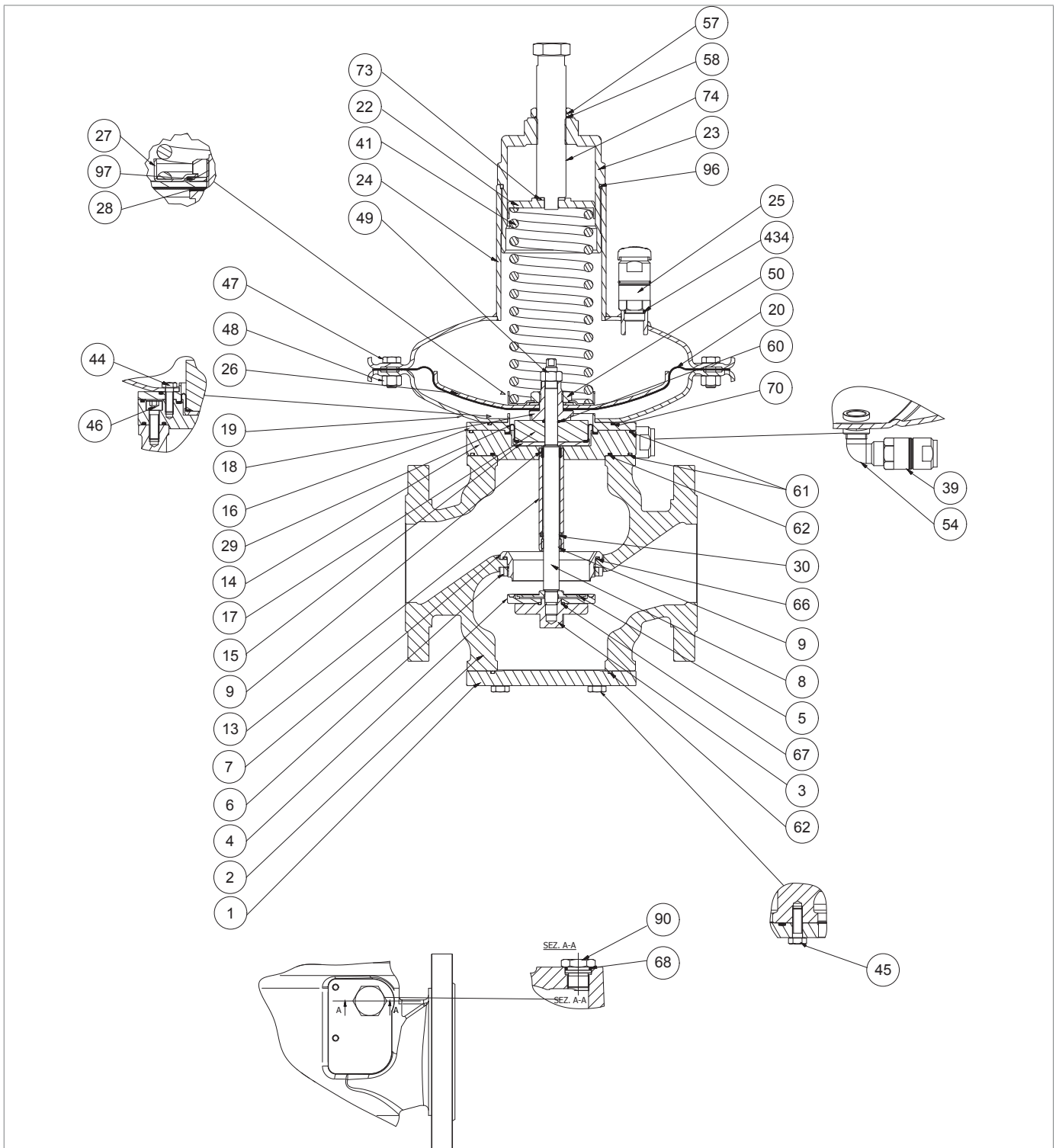
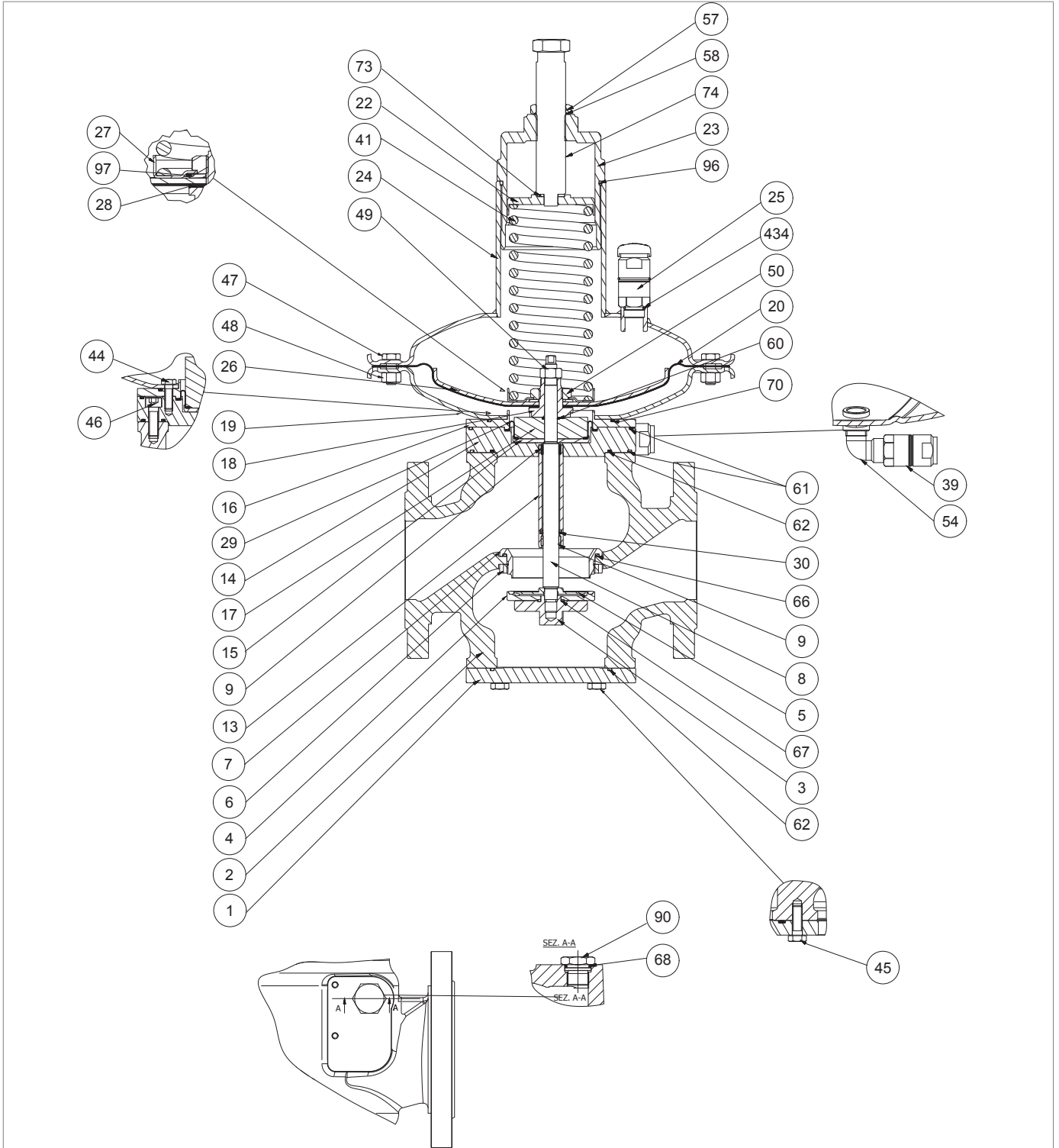







Fig. 9.38. NORVAL Regulator 2" 1/2 - 3" (head 375)

Step	Action
1	Unscrew the lock nut (57).
2	Undo and remove the adjustment screw (74).
3	Remove the O-ring (58) from the lock nut (44) and replace it, taking care to lubricate it with synthetic grease. <div style="border: 1px solid black; padding: 5px;">! NOTICE! Before inserting the replacement O-ring, clean the retaining slots with a cleaning solution.</div>
4	Unscrew and remove the cap (23).
5	Remove the O-ring (96) from the cap (23) and replace it, taking care to lubricate it with synthetic grease. <div style="border: 1px solid black; padding: 5px;">! NOTICE! Before inserting the replacement O-ring, clean the retaining slots with a cleaning solution.</div>
6	Remove the spring guide disc (22) together with the disc (73).
7	Remove the setting spring (41).
8	Unscrew and remove the anti-pumping valve (25) from the top cover (24).
9	Remove the O-ring (434) and replace it, taking care to lubricate it with synthetic grease. <div style="border: 1px solid black; padding: 5px;">! NOTICE! Before inserting the replacement O-ring, clean the retaining slots with a cleaning solution.</div>
10	Position and secure the anti-pumping valve (25) in the top cover (24).
11	Undo and remove the screws (45).
12	Remove the lower flange (1). <div style="background-color: yellow; padding: 5px;">! ATTENTION! In the presence of the ER device, refer to paragraph 9.4.5 for maintenance.</div>
13	Remove the O-ring (62) from the lower flange (1) and replace it, taking care to lubricate it with synthetic grease. <div style="border: 1px solid black; padding: 5px;">! NOTICE! Before inserting the replacement O-ring, clean the retaining slots with a cleaning solution.</div>
14	Unscrew the locking nut (3) together with the reinforced gasket (4), the disc (5) and the O-ring (67) and remove them from the rod (8).
15	Remove the O-ring (67) from the lock nut (3), taking care to lubricate it with synthetic grease. <div style="border: 1px solid black; padding: 5px;">! NOTICE! Before inserting the replacement O-ring, clean the retaining slots with a cleaning solution.</div>
16	Replace the reinforced gasket (4).
17	Undo and remove the nut (48) and the screw (47).
18	Remove the top cover (24).



NORVAL Regulator 2" 1/2 - 3" (head 375)

Step	Action
19	Unscrew and remove the locking nut (49).  NOTICE! During this phase, keep the rod (8) still.
20	Remove the diaphragm assembly (18, 20, 26, 27, 28, 50, 97) placing it on a shockproof surface.
21	Unscrew and remove the nut (50).  NOTICE! During this phase, keep the diaphragm support (18) still.
22	Remove the spring guide (27).
23	Remove the spring (97).
24	Remove the diaphragm protection disc (26).
25	Remove the diaphragm (20).
26	Fit the diaphragm (20).
27	Fit the diaphragm protection disc (26).
28	Fit the spring (97).
29	Fit the spring guide (27).
30	Insert and fix the nut (50) according to the following tightening torques: <ul style="list-style-type: none"> • 2" 1/2: tab. 9.66 • 3": tab. 9.68  NOTICE! During this phase, keep the diaphragm support (18) still.
31	Pull out the rod (8) from the top downwards.
32	Remove the spacer (17).
33	Remove the O-ring (60) and replace it, taking care to lubricate it with synthetic grease.  NOTICE! Before inserting the replacement O-ring, clean the retaining slots with a cleaning solution.
34	Undo and remove the screws (44).
35	Remove the bottom cover (19) from the bush (16).
36	Remove the O-ring (70) from the bush (16) and replace it, taking care to lubricate it with synthetic grease.  NOTICE! Before inserting the replacement O-ring, clean the retaining slots with a cleaning solution.
37	Remove the bush (16).
38	Remove the O-ring (61) from the flange (14), taking care to lubricate it with synthetic grease.  NOTICE! Before inserting the replacement O-ring, clean the retaining slots with a cleaning solution.

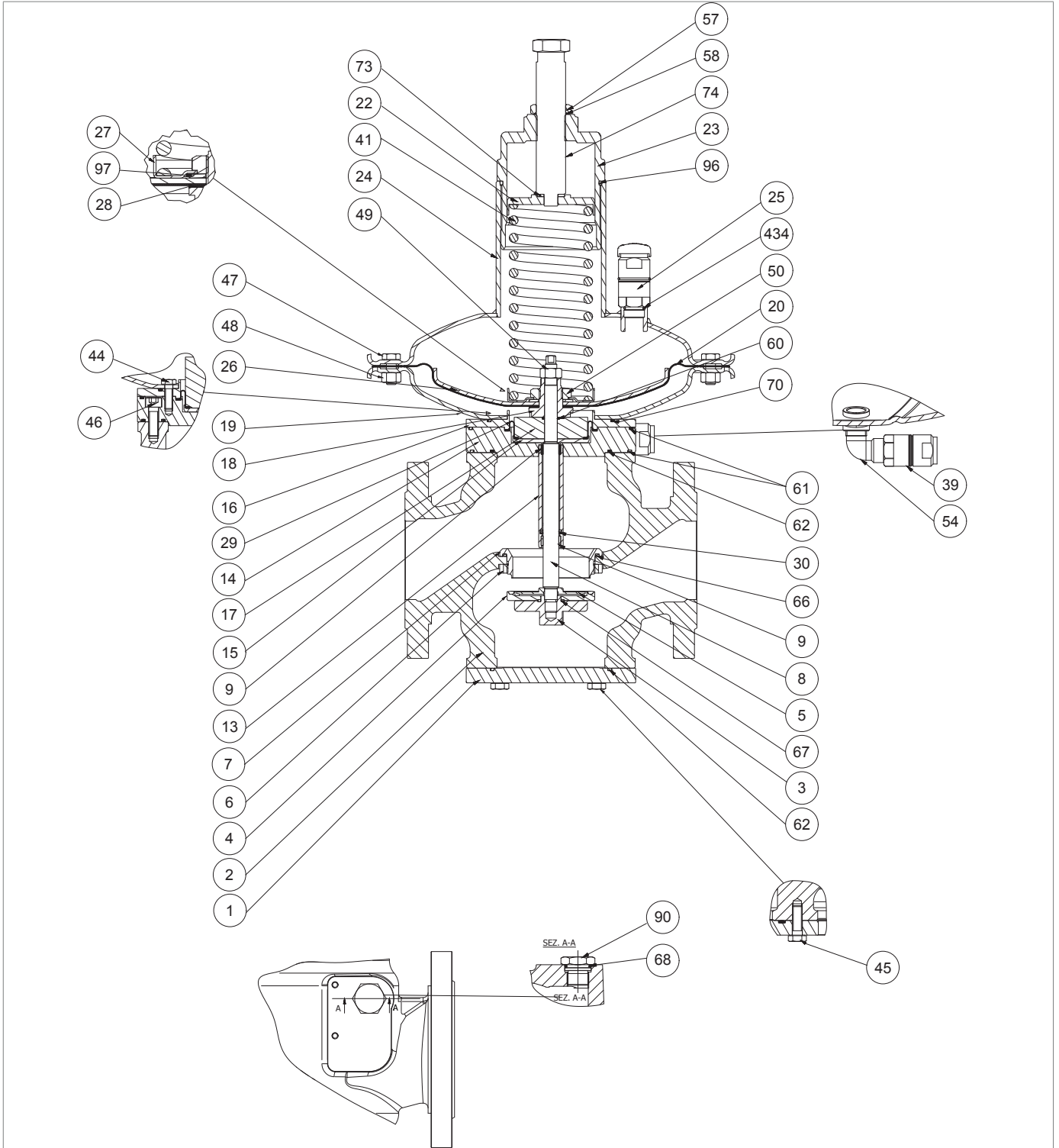



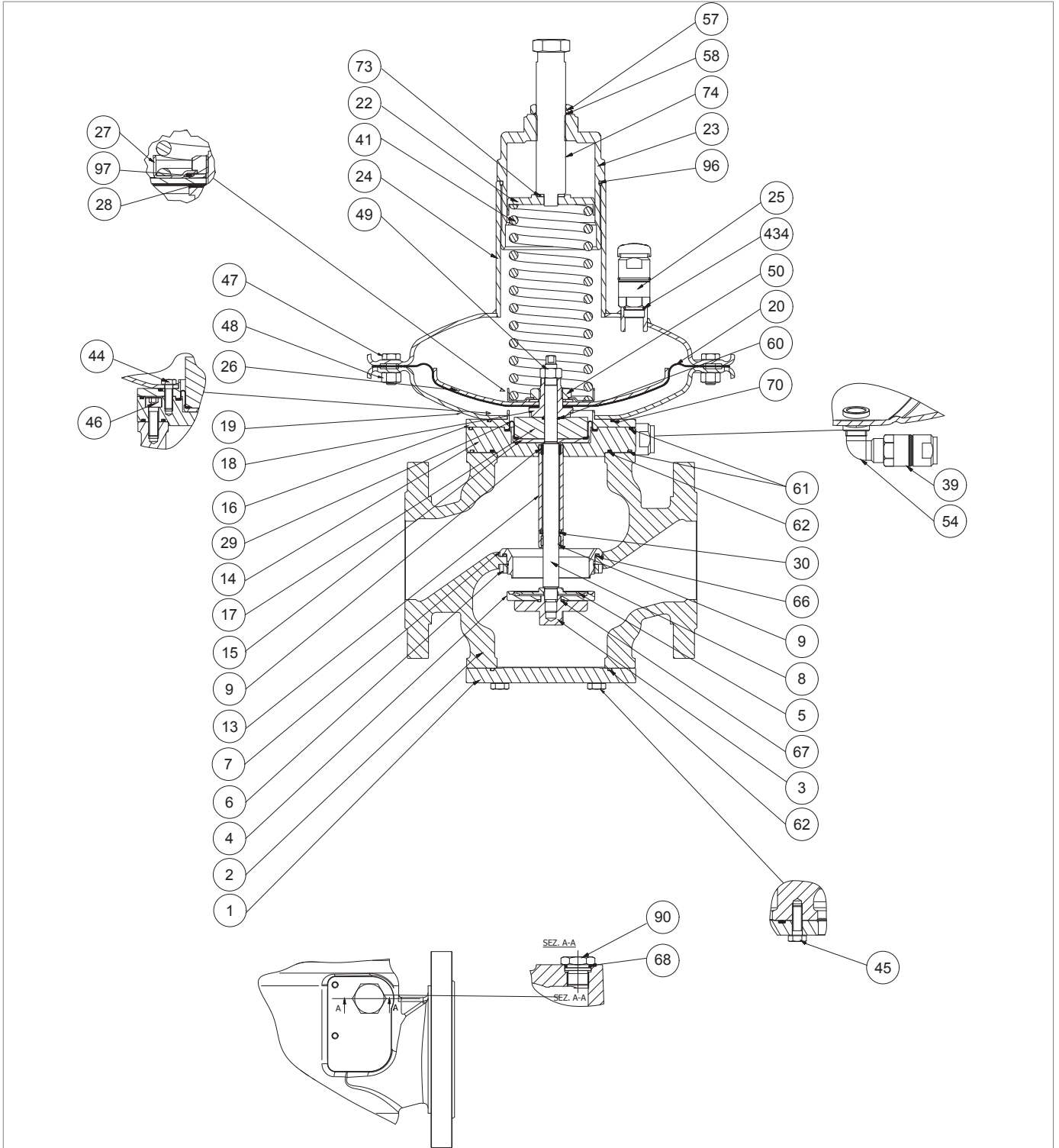

NORVAL Regulator 2" 1/2 - 3" (head 375)

Step	Action
39	Remove the balancing diaphragm (29) and replace it, taking care to lubricate it with synthetic grease. ! NOTICE! Before inserting the replacement O-ring, clean the retaining slots with a cleaning solution.
40	Remove the shaft collar (15).
41	Undo and remove the screws (46).
42	Remove the flange (14) from the body (2) together with the rod guide sleeve (13). ! ATTENTION! In the presence of the SN slam-shut valve, see paragraph 9.4.6 for maintenance.
43	Remove the I/DWR ring (9) from the rod guide (13) and replace it. ! NOTICE! Before inserting the replacement I/DWR ring, clean the retaining slots with a cleaning solution.
44	Remove the lip seal (30) from the rod guide sleeve (13) and replace it. ! NOTICE! <ul style="list-style-type: none"> • Before inserting the replacement seal, clean the retaining slots with a cleaning solution • Direct the gasket cavity towards the valve seat (7)
45	Remove the O-rings (61, 62) from the flange (14) and replace them, taking care to lubricate them with synthetic grease. ! NOTICE! Before inserting the replacement O-rings, clean the retaining slots with a cleaning solution.
46	Undo and remove the locking ring nut (6).
47	Pull the valve seat (7) out of the body (2) from the bottom upwards.
48	Remove the O-ring (66) from the body (2) and replace it, taking care to lubricate them with synthetic grease. ! NOTICE! Before inserting the replacement O-ring, clean the retaining slots with a cleaning solution.
49	Insert the valve seat (7) into the body (2) from the top downwards.
50	Insert the locking ring nut (6) and secure it according to the following tightening torques: <ul style="list-style-type: none"> • 2" 1/2: tab. 9.66 • 3": tab. 9.68
51	Insert the flange (14) into the body (2) together with the rod guide sleeve (13) and the O-rings (61, 62).
52	Insert and fix the screws (46) according to the following tightening torques: <ul style="list-style-type: none"> • 2" 1/2: tab. 9.66 • 3": tab. 9.68 ! NOTICE! Tighten the screws according to the cross diagram in paragraph 9.4.2.2.



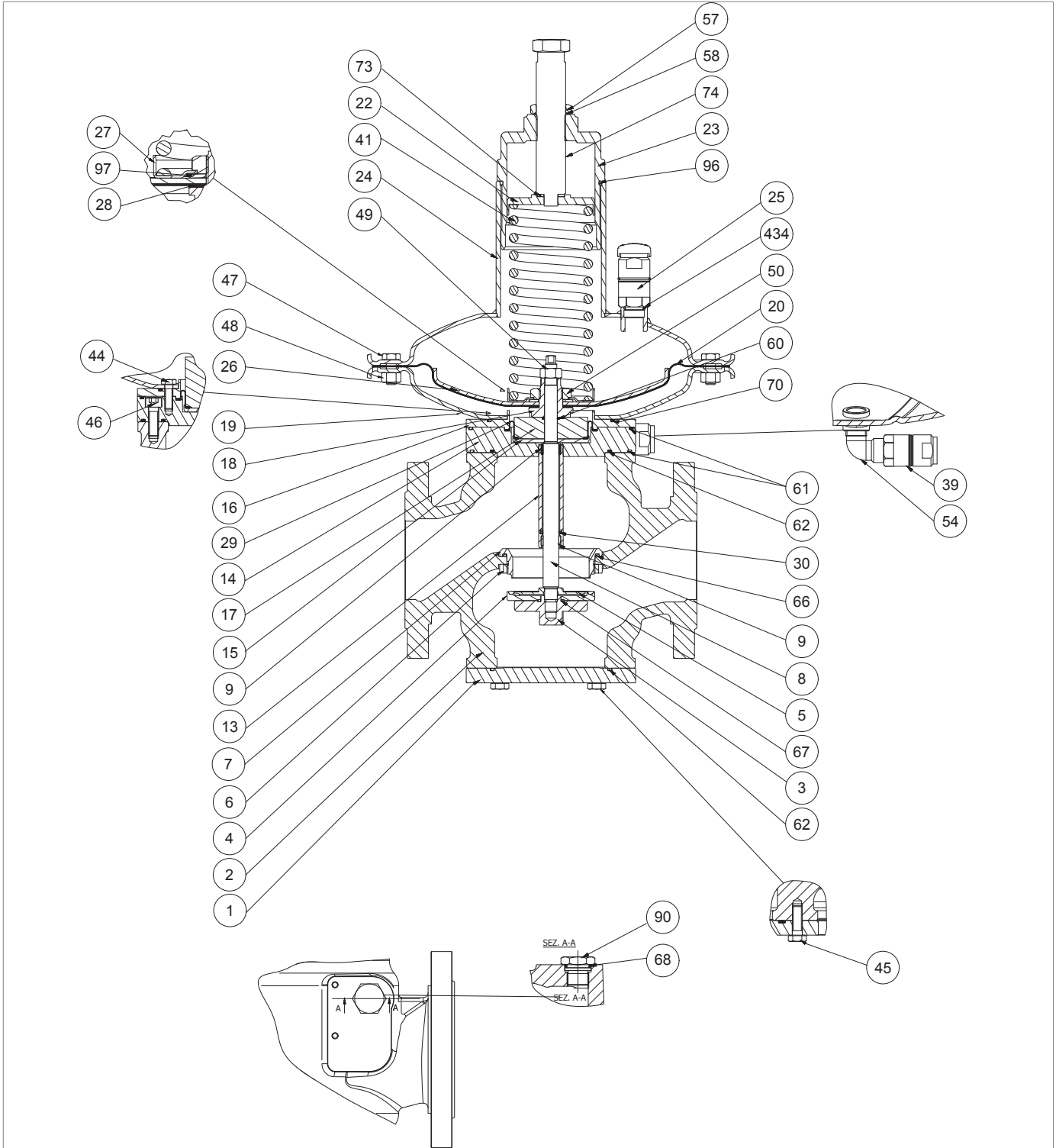

NORVAL Regulator 2" 1/2 - 3" (head 375)

Step	Action
53	Fit the shaft collar (15).
54	Fit the balancing diaphragm (29).
55	Fit the bush (16).
56	Insert the O-ring (61) and lubricate it with synthetic grease.  NOTICE! Before inserting the replacement O-ring, clean the retaining slots with a cleaning solution.
57	Fit the bottom cover (19) on the bush (16).
58	Insert and fix the screws (44) according to the following tightening torques: <ul style="list-style-type: none"> • 2" 1/2: tab. 9.66 • 3": tab. 9.68  NOTICE! Tighten the screws according to the cross diagram in paragraph 9.4.2.2.
59	Position the spacer (17) together with the O-ring (60).
60	Place the diaphragm assembly (18, 20, 26, 27, 28, 50, 97) in the spacer (17).
61	Insert the rod (8) into the body (2) from the bottom upwards.
62	Align the holes of the main diaphragm (20) with the holes of the bottom cover (19).
63	Insert the locking nut (49) according to the following tightening torques: <ul style="list-style-type: none"> • 2" 1/2: tab. 9.66 • 3": tab. 9.68  NOTICE! During this phase, keep the rod (8) and the diaphragm support (18) still.
64	Fit the top cover (24).  NOTICE! Align the anti-pumping valve (25) in the direction of the downstream flow.
65	Insert the screws (47) into the top cover (24) and bottom cover (19).
66	Insert the nuts (48) into the screws (47).
67	Secure the screws (47) according to the following tightening torques: <ul style="list-style-type: none"> • 2" 1/2: tab. 9.66 • 3": tab. 9.68  NOTICE! Tighten the screws according to the cross diagram in paragraph 9.4.2.2.
68	Insert the setting spring (41).
69	Insert the spring guide disc (22) together with the disc (73).
70	Insert and fix the cap (23).
71	Insert the adjustment screw (74) together with the O-ring (58) and the locking nut (44).



NORVAL Regulator 2" 1/2 - 3" (head 375)

Step	Action
72	Insert and fasten the locking nut (57).
73	Insert the locking nut (3) together with the reinforced gasket (4), the disc (5) and the O-ring (67) from the bottom upwards, according to the following tightening torques: <ul style="list-style-type: none"> • 2" 1/2: tab. 9.66 • 3": tab. 9.68
73	Fasten the locking nut (3) to the rod (8).
74	Fit the lower flange (1) together with the O-ring (62).
75	Insert and fix the screws (45) according to the following tightening torques: <ul style="list-style-type: none"> • 2" 1/2: tab. 9.66 • 3": tab. 9.68 <div style="border: 1px solid black; padding: 5px; margin-top: 5px;">  NOTICE! Tighten the screws according to the cross diagram in paragraph 9.4.2.2. </div>
76	Unscrew and remove the cap (90) together with the O-ring (68) from the front of the body (2).
77	Remove the O-ring (68) and replace it, taking care to lubricate it with synthetic grease. <div style="border: 1px solid black; padding: 5px; margin-top: 5px;">  NOTICE! Before inserting the replacement O-ring, clean the retaining slots with a cleaning solution. </div>
78	Position the cap (90) in the body (2).

Tab. 9.95.

 **WARNING!**

Ensure that all parts have been fitted correctly.

9.4.4.6 - NORVAL REGULATOR 2" 1/2 - 3" (HEAD 495)

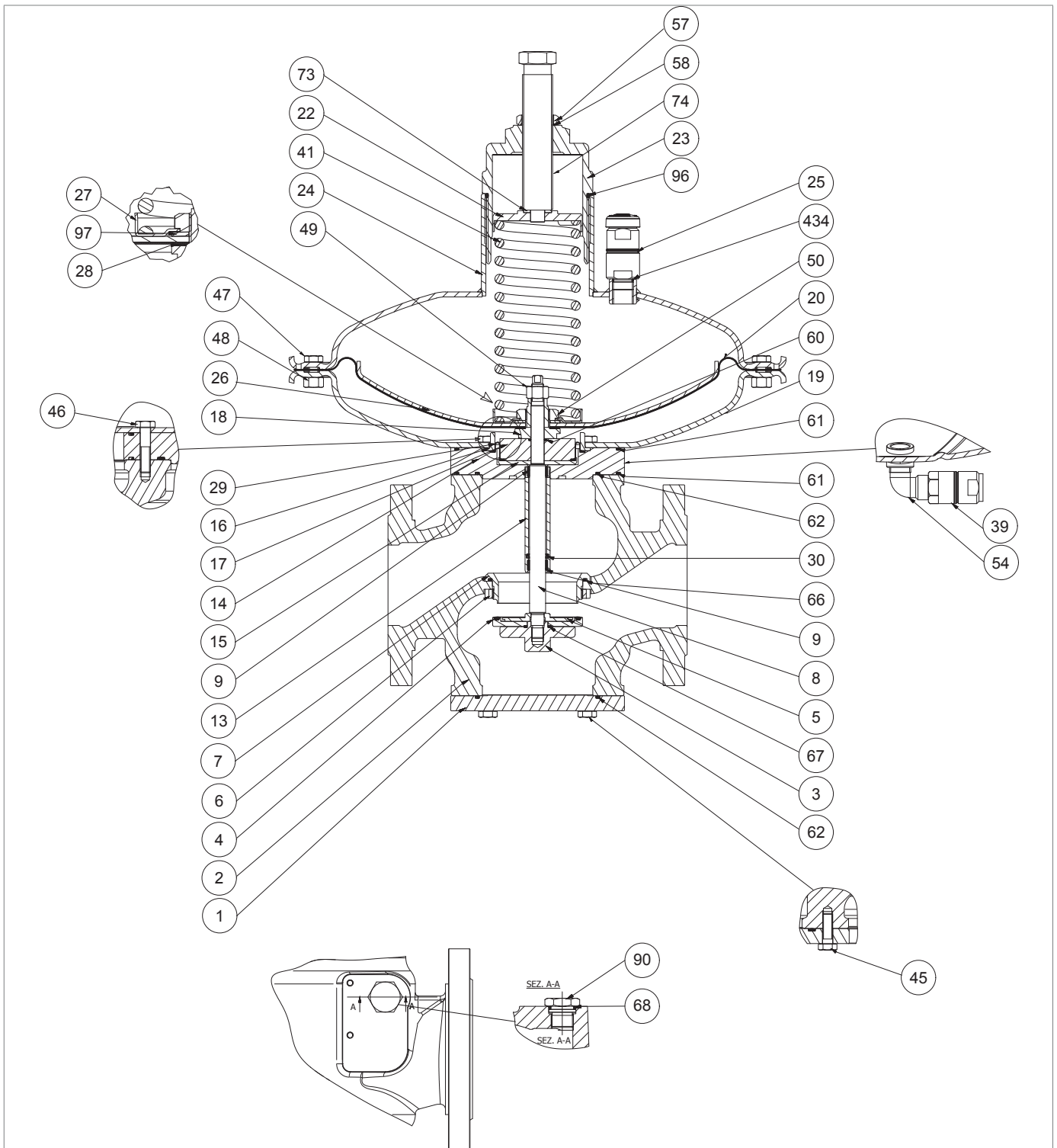
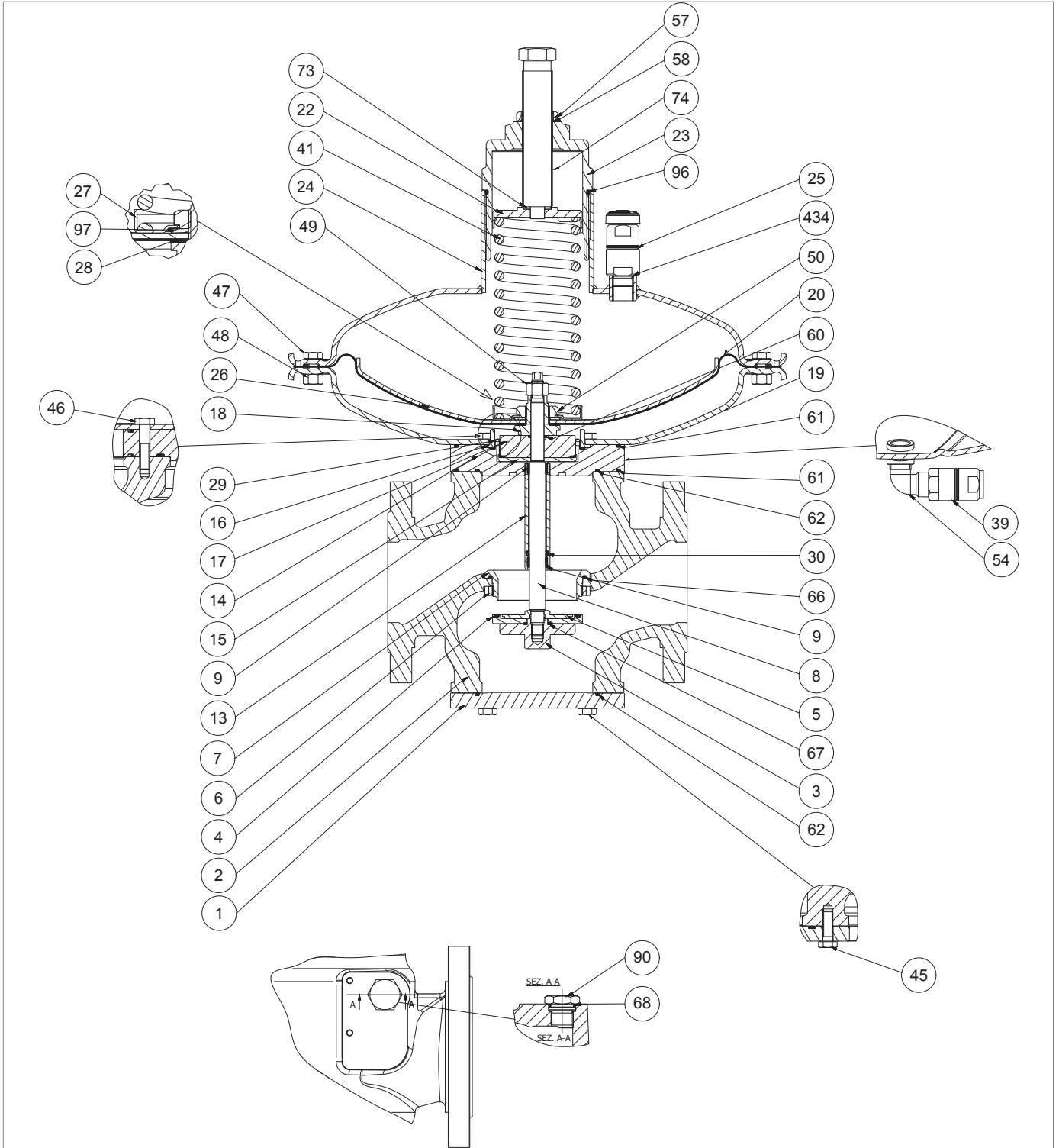







Fig. 9.39. NORVAL Regulator 2" 1/2 - 3" (head 495)

Step	Action
1	Unscrew the lock nut (57).
2	Undo and remove the adjustment screw (74).
3	Remove the O-ring (58) from the lock nut (44) and replace it, taking care to lubricate it with synthetic grease. <div style="border: 1px solid black; padding: 5px;">! NOTICE! Before inserting the replacement O-ring, clean the retaining slots with a cleaning solution.</div>
4	Unscrew and remove the cap (23).
5	Remove the O-ring (96) from the cap (23) and replace it, taking care to lubricate it with synthetic grease. <div style="border: 1px solid black; padding: 5px;">! NOTICE! Before inserting the replacement O-ring, clean the retaining slots with a cleaning solution.</div>
6	Remove the spring guide disc (22) together with the disc (73).
7	Remove the setting spring (41).
8	Unscrew and remove the anti-pumping valve (25) from the top cover (24).
9	Remove the O-ring (434) and replace it, taking care to lubricate it with synthetic grease. <div style="border: 1px solid black; padding: 5px;">! NOTICE! Before inserting the replacement O-ring, clean the retaining slots with a cleaning solution.</div>
10	Position and secure the anti-pumping valve (25) in the top cover (24).
11	Undo and remove the screws (45).
12	Remove the lower flange (1). <div style="background-color: yellow; padding: 5px;">! ATTENTION! In the presence of the ER device, refer to paragraph 9.4.5 for maintenance.</div>
13	Remove the O-ring (62) from the lower flange (1) and replace it, taking care to lubricate it with synthetic grease. <div style="border: 1px solid black; padding: 5px;">! NOTICE! Before inserting the replacement O-ring, clean the retaining slots with a cleaning solution.</div>
14	Unscrew the locking nut (3) together with the reinforced gasket (4), the disc (5) and the O-ring (67) and remove them from the rod (8).
15	Remove the O-ring (67) from the lock nut (3), taking care to lubricate it with synthetic grease. <div style="border: 1px solid black; padding: 5px;">! NOTICE! Before inserting the replacement O-ring, clean the retaining slots with a cleaning solution.</div>
16	Replace the reinforced gasket (4).
17	Undo and remove the nut (48) and the screw (47).
18	Remove the top cover (24).



NORVAL Regulator 2" 1/2 - 3" (head 495)

Step	Action
19	Unscrew and remove the locking nut (49). <div style="border: 1px solid blue; padding: 5px;">  NOTICE! During this phase, keep the rod (8) still. </div>
20	Remove the diaphragm assembly (18, 20, 26, 27, 28, 50, 97) placing it on a shockproof surface.
21	Unscrew and remove the nut (50). <div style="border: 1px solid blue; padding: 5px;">  NOTICE! During this phase, keep the diaphragm support (18) still. </div>
22	Remove the spring guide (27).
23	Remove the spring (97).
24	Remove the diaphragm protection disc (26).
25	Remove the diaphragm (20).
26	Fit the diaphragm (20).
27	Fit the diaphragm protection disc (26).
28	Fit the spring (97).
29	Fit the spring guide (27).
30	Insert and fix the nut (50) according to the following tightening torques: <ul style="list-style-type: none"> • 2" 1/2: tab. 9.67 • 3": tab. 9.69 <div style="border: 1px solid blue; padding: 5px;">  NOTICE! During this phase, keep the diaphragm support (18) still. </div>
31	Pull out the rod (8) from the top downwards.
32	Remove the spacer (17).
33	Remove the O-ring (60) from the spacer (17) and replace it, taking care to lubricate it with synthetic grease. <div style="border: 1px solid blue; padding: 5px;">  NOTICE! Before inserting the replacement O-ring, clean the retaining slots with a cleaning solution. </div>
34	Undo and remove the screws (44).
35	Remove the bottom cover (19) from the bush (16).
36	Remove the O-ring (70) and replace it, taking care to lubricate it with synthetic grease. <div style="border: 1px solid blue; padding: 5px;">  NOTICE! Before inserting the replacement O-ring, clean the retaining slots with a cleaning solution. </div>
37	Remove the bush (16).
38	Remove the O-ring (61) from the flange (14) and replace it, taking care to lubricate it with synthetic grease. <div style="border: 1px solid blue; padding: 5px;">  NOTICE! Before inserting the replacement O-ring, clean the retaining slots with a cleaning solution. </div>

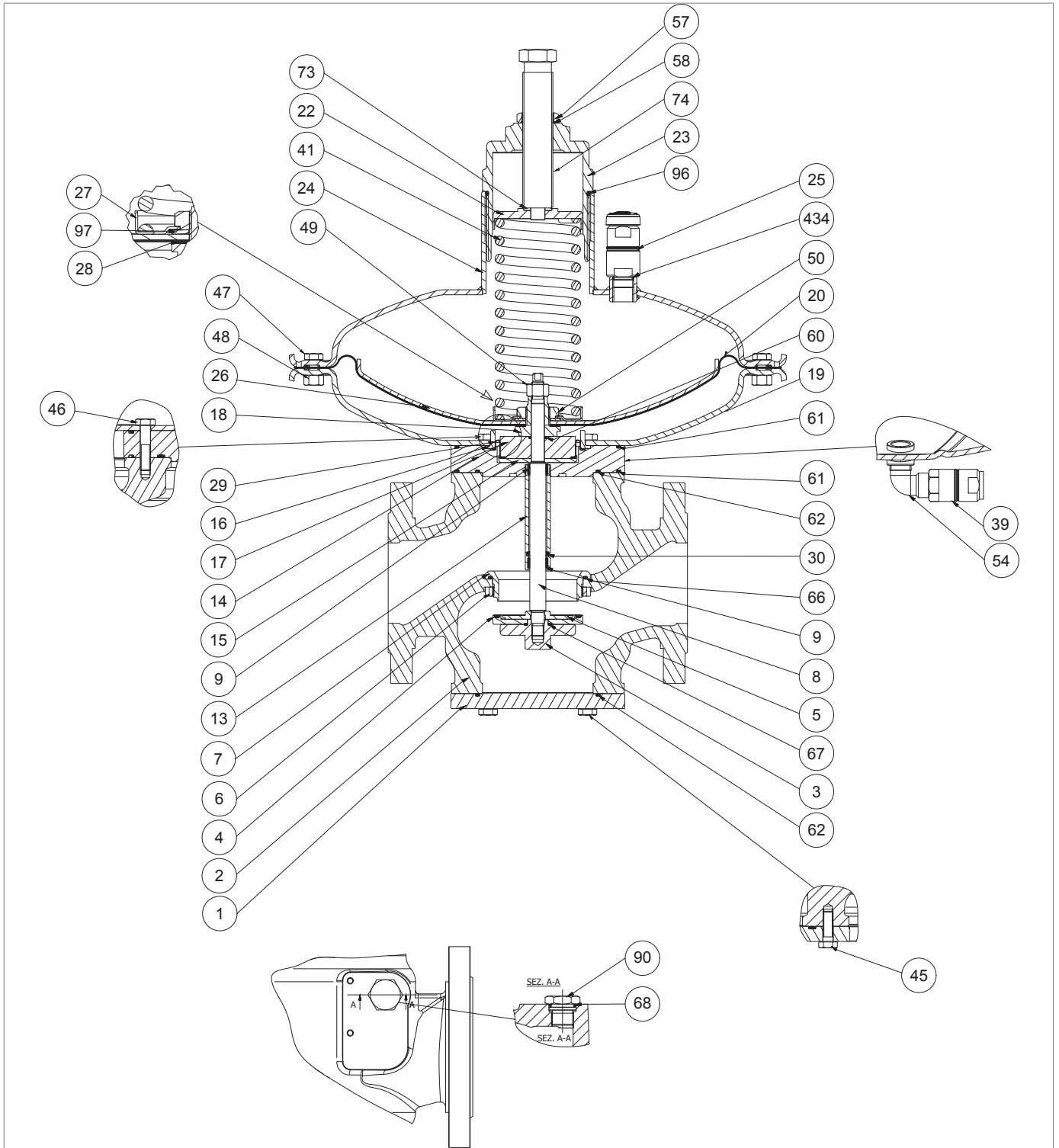



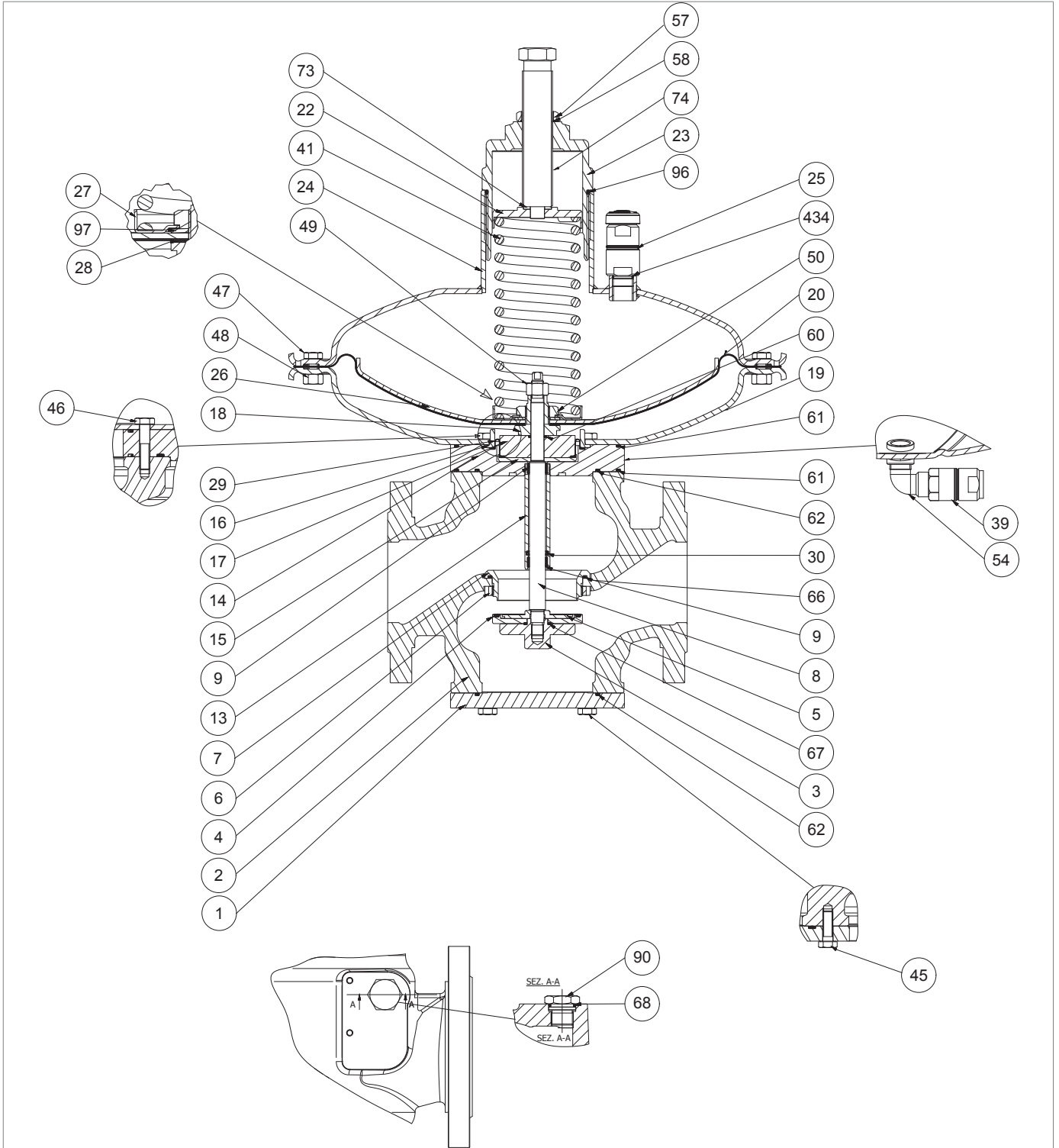

NORVAL Regulator 2" 1/2 - 3" (head 495)

Step	Action
39	Remove the balancing diaphragm (29) and replace it, taking care to lubricate it with synthetic grease. ! NOTICE! Before inserting the replacement diaphragm, clean the retaining slots with a cleaning solution.
40	Remove the shaft collar (15).
41	Undo and remove the screws (46).
42	Remove the flange (14) from the body (2) together with the rod guide sleeve (13). ! ATTENTION! In the presence of the SN slam-shut valve, see paragraph 9.4.6 for maintenance.
43	Remove the I/DWR ring (9) and the lip seal (30) from the rod guide sleeve (13) and replace them. ! NOTICE! Before inserting the replacement I/DWR ring, clean the retaining slots with a cleaning solution.
44	Remove the O-rings (61, 62) from the flange (14) and replace them, taking care to lubricate them with synthetic grease. ! NOTICE! Before inserting the replacement O-rings, clean the retaining slots with a cleaning solution.
45	Undo and remove the locking ring nut (6).
46	Pull the valve seat (7) out of the body (2) from the bottom upwards.
47	Remove the O-ring (66) from the body (2) and replace it, taking care to lubricate them with synthetic grease. ! NOTICE! Before inserting the replacement O-ring, clean the retaining slots with a cleaning solution.
48	Insert the valve seat (7) into the body (2) from the top downwards.
49	Insert the locking ring nut (6) and secure it according to the following tightening torques: <ul style="list-style-type: none"> • 2" 1/2: tab. 9.67 • 3": tab. 9.69
50	Insert the flange (14) into the body (2) together with the rod guide sleeve (13) and the O-rings (61 lower, 62).
51	Insert and fix the screws (46) according to the following tightening torques: <ul style="list-style-type: none"> • 2" 1/2: tab. 9.67 • 3": tab. 9.69 ! NOTICE! Tighten the screws according to the cross diagram in paragraph 9.4.2.2.
52	Fit the shaft collar (15).
53	Fit the balancing diaphragm (29).
54	Fit the bush (16).
55	Insert the O-ring (61 upper).
56	Fit the bottom cover (19) on the bush (16).



NORVAL Regulator 2" 1/2 - 3" (head 495)

Step	Action
57	Insert and fix the screws (44) according to the following tightening torques: <ul style="list-style-type: none"> • 2" 1/2: tab. 9.67 • 3": tab. 9.69 <div style="border: 1px solid black; padding: 5px;">  NOTICE! Tighten the screws according to the cross diagram in paragraph 9.4.2.2. </div>
58	Position the spacer (17) together with the O-ring (60).
59	Place the diaphragm assembly (18, 20, 26, 27, 28, 50, 97) in the spacer (17).
60	Insert the rod (8) into the body (2) from the bottom upwards.
61	Align the holes of the main diaphragm (20) with the holes of the bottom cover (19).
62	Insert the locking nut (49) according to the following tightening torques: <ul style="list-style-type: none"> • 2" 1/2: tab. 9.67 • 3": tab. 9.69 <div style="border: 1px solid black; padding: 5px;">  NOTICE! During this phase, keep the rod (8) and the diaphragm support (18) still. </div>
63	Fit the top cover (24).
64	Insert the screws (47) into the top cover (24) and bottom cover (19).
65	Insert the nuts (48) into the screws (47).
66	Secure the screws (47) according to the following tightening torques: <ul style="list-style-type: none"> • 2" 1/2: tab. 9.67 • 3": tab. 9.69 <div style="border: 1px solid black; padding: 5px;">  NOTICE! Tighten the screws according to the cross diagram in paragraph 9.4.2.2. </div>
67	Insert the setting spring (41).
68	Insert the spring guide disc (22) together with the disc (73).
69	Insert and fix the cap (23).
70	Insert the adjustment screw (74) together with the O-ring (58) and the locking nut (44).
71	Insert and fasten the locking nut (57).
73	Insert the locking nut (3) together with the reinforced gasket (4), the disc (5) and the O-ring (67) and secure them to the rod (8) from the bottom upwards.
74	Fit the lower flange (1) together with the O-ring (62).
75	Insert and fix the screws (45) according to the following tightening torques: <ul style="list-style-type: none"> • 2" 1/2: tab. 9.84 • 3": tab. 9.86 <div style="border: 1px solid black; padding: 5px;">  NOTICE! Tighten the screws according to the cross diagram in paragraph 9.4.2.2. </div>

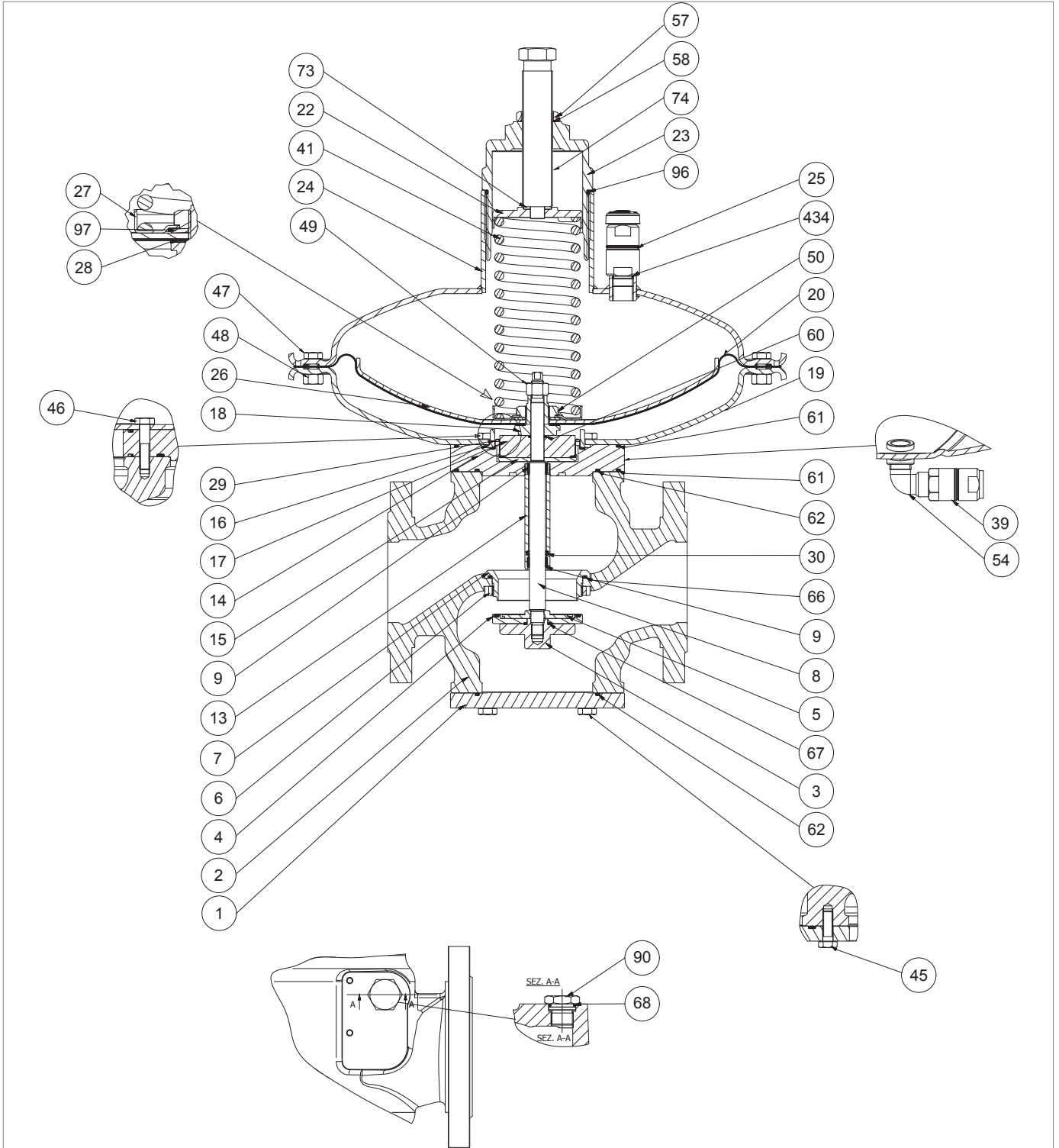

NORVAL Regulator 2" 1/2 - 3" (head 495)

Step	Action
76	Unscrew and remove the cap (90) together with the O-ring (68) from the front of the body (2).
77	Remove the O-ring (68) and replace it, taking care to lubricate it with synthetic grease. <div style="border: 1px solid black; padding: 5px; margin-top: 5px;">  NOTICE! Before inserting the replacement O-ring, clean the retaining slots with a cleaning solution. </div>
78	Position the cap (90) in the body (2).

Tab. 9.96.

 **WARNING!**

Ensure that all parts have been fitted correctly.

9.4.4.7 - NORVAL REGULATOR 2" 1/2 - 3" (HEAD 630)

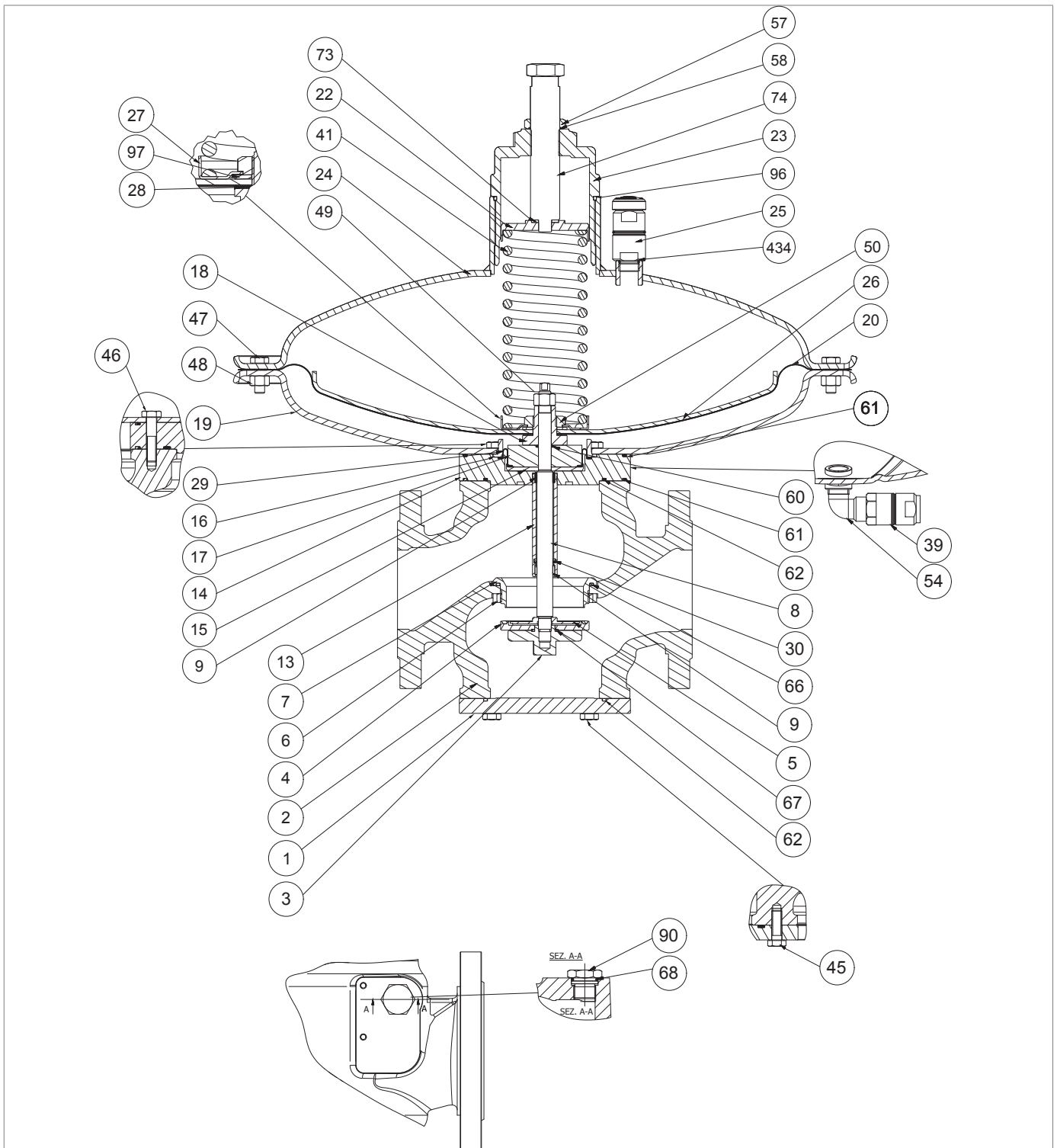
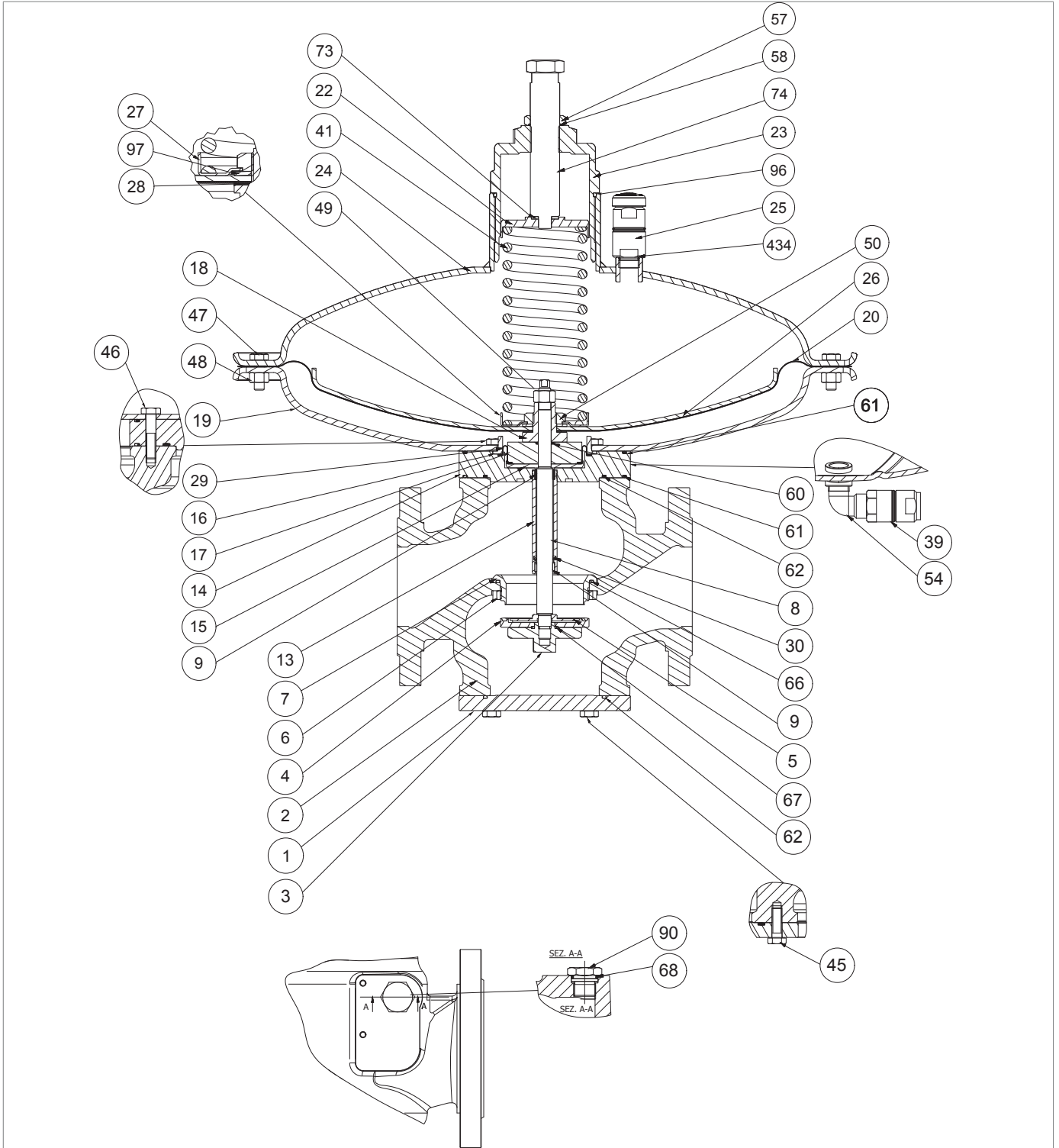







Fig. 9.40. NORVAL Regulator 2" 1/2 - 3" (head 630)

Step	Action
1	Unscrew the lock nut (57).
2	Undo and remove the adjustment screw (74).
3	Remove the O-ring (58) from the lock nut (44) and replace it, taking care to lubricate it with synthetic grease. <div style="border: 1px solid black; padding: 5px;">! NOTICE! Before inserting the replacement O-ring, clean the retaining slots with a cleaning solution.</div>
4	Unscrew and remove the cap (23).
5	Remove the O-ring (96) from the cap (23) and replace it, taking care to lubricate it with synthetic grease. <div style="border: 1px solid black; padding: 5px;">! NOTICE! Before inserting the replacement O-ring, clean the retaining slots with a cleaning solution.</div>
6	Remove the spring guide disc (22) together with the disc (73).
7	Remove the setting spring (41).
8	Unscrew and remove the anti-pumping valve (25) from the top cover (24).
9	Remove the O-ring (434) and replace it, taking care to lubricate it with synthetic grease. <div style="border: 1px solid black; padding: 5px;">! NOTICE! Before inserting the replacement O-ring, clean the retaining slots with a cleaning solution.</div>
10	Position and secure the anti-pumping valve (25) in the top cover (24).
11	Undo and remove the screws (45).
12	Remove the lower flange (1). <div style="background-color: yellow; padding: 5px;">! ATTENTION! In the presence of the ER device, refer to paragraph 9.4.5 for maintenance.</div>
13	Remove the O-ring (62) from the lower flange (1) and replace it, taking care to lubricate it with synthetic grease. <div style="border: 1px solid black; padding: 5px;">! NOTICE! Before inserting the replacement O-ring, clean the retaining slots with a cleaning solution.</div>
14	Unscrew the locking nut (3) together with the reinforced gasket (4), the disc (5) and the O-ring (67) and remove them from the rod (8).
15	Remove the O-ring (67) from the lock nut (3), taking care to lubricate it with synthetic grease. <div style="border: 1px solid black; padding: 5px;">! NOTICE! Before inserting the replacement O-ring, clean the retaining slots with a cleaning solution.</div>
16	Replace the reinforced gasket (4).
17	Undo and remove the nut (48) and the screw (47).
18	Remove the top cover (24).



NORVAL Regulator 2" 1/2 - 3" (head 630)

Step	Action
19	Unscrew and remove the locking nut (49).  NOTICE! During this phase, keep the rod (8) still.
20	Remove the diaphragm assembly (18, 20, 26, 27, 28, 50, 97) placing it on a shockproof surface.
21	Unscrew and remove the nut (50).  NOTICE! During this phase, keep the diaphragm support (18) still.
22	Remove the spring guide (27).
23	Remove the spring (97).
24	Remove the diaphragm protection disc (26).
25	Remove the diaphragm (20).
26	Fit the diaphragm (20).
27	Fit the diaphragm protection disc (26).
28	Fit the spring (97).
29	Fit the spring guide (27).
30	Insert and fix the nut (50) according to the following tightening torques: <ul style="list-style-type: none"> • 2" 1/2: tab. 9.67 • 3": tab. 9.69  NOTICE! During this phase, keep the diaphragm support (18) still.
31	Pull out the rod (8) from the top downwards.
32	Remove the spacer (17).
33	Remove the O-ring (60) from the spacer (17) and replace it, taking care to lubricate it with synthetic grease.  NOTICE! Before inserting the replacement O-ring, clean the retaining slots with a cleaning solution.
34	Undo and remove the screws (44).
35	Remove the bottom cover (19) from the bush (16).
36	Remove the O-ring (70) and replace it, taking care to lubricate it with synthetic grease.  NOTICE! Before inserting the replacement O-ring, clean the retaining slots with a cleaning solution.
37	Remove the bush (16).
38	Remove the O-ring (61 upper) from the flange (14).
39	Remove the balancing diaphragm (29) and replace it, taking care to lubricate it with synthetic grease.  NOTICE! Before inserting the replacement diaphragm, clean the retaining slots with a cleaning solution.

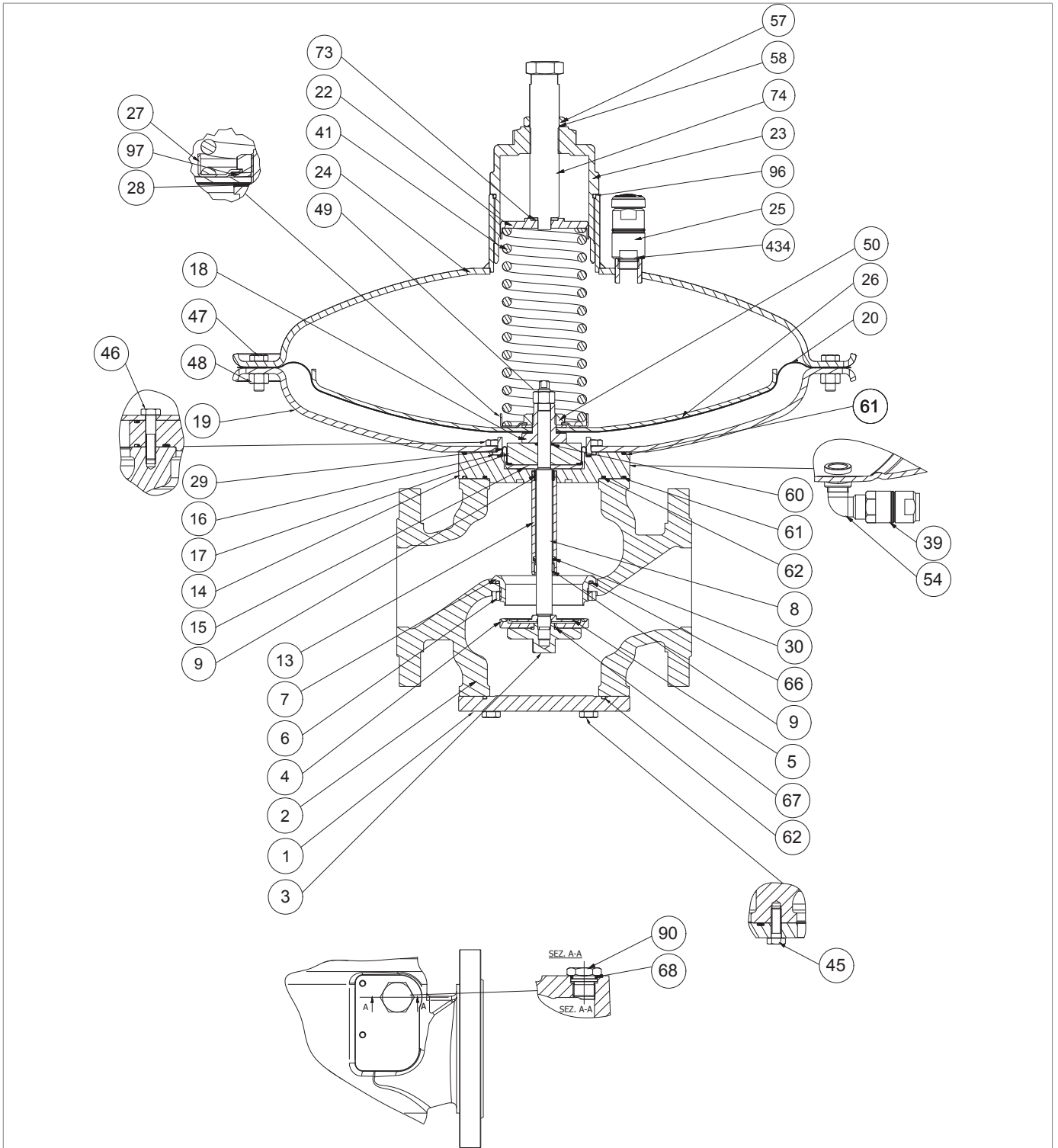

NORVAL Regulator 2" 1/2 - 3" (head 630)

Step	Action
40	Remove the shaft collar (15).
41	Undo and remove the screws (46).
42	Remove the flange (14) from the body (2) together with the rod guide sleeve (13). ⚠ ATTENTION! In the presence of the SN slam-shut valve, see paragraph 9.4.6 for maintenance.
43	Remove the I/DWR ring (9) and the lip seal (30) from the rod guide sleeve (13) and replace them. ! NOTICE! Before inserting the replacement I/DWR ring, clean the retaining slots with a cleaning solution.
44	Remove the O-rings (61 lower, 62) from the flange (14) and replace them, taking care to lubricate them with synthetic grease. ! NOTICE! Before inserting the replacement O-rings, clean the retaining slots with a cleaning solution.
45	Undo and remove the locking ring nut (6).
46	Pull the valve seat (7) out of the body (2) from the bottom upwards.
47	Remove the O-ring (66) from the body (2) and replace it, taking care to lubricate them with synthetic grease. ! NOTICE! Before inserting the replacement O-ring, clean the retaining slots with a cleaning solution.
48	Insert the valve seat (7) into the body (2) from the top downwards.
49	Insert the locking ring nut (6) and secure it according to the following tightening torques: <ul style="list-style-type: none"> • 2" 1/2: tab. 9.67 • 3": tab. 9.69
50	Insert the flange (14) into the body (2) together with the rod guide sleeve (13) and the O-rings (61 lower, 62).
51	Insert and fix the screws (46) according to the following tightening torques: <ul style="list-style-type: none"> • 2" 1/2: tab. 9.67 • 3": tab. 9.69 ! NOTICE! Tighten the screws according to the cross diagram in paragraph 9.4.2.2.
52	Fit the shaft collar (15).
53	Fit the balancing diaphragm (29).
54	Fit the bush (16).
55	Insert the O-ring (61) and lubricate it with synthetic grease. ! NOTICE! Before inserting the replacement O-ring, clean the retaining slots with a cleaning solution.
56	Fit the bottom cover (19) on the bush (16).

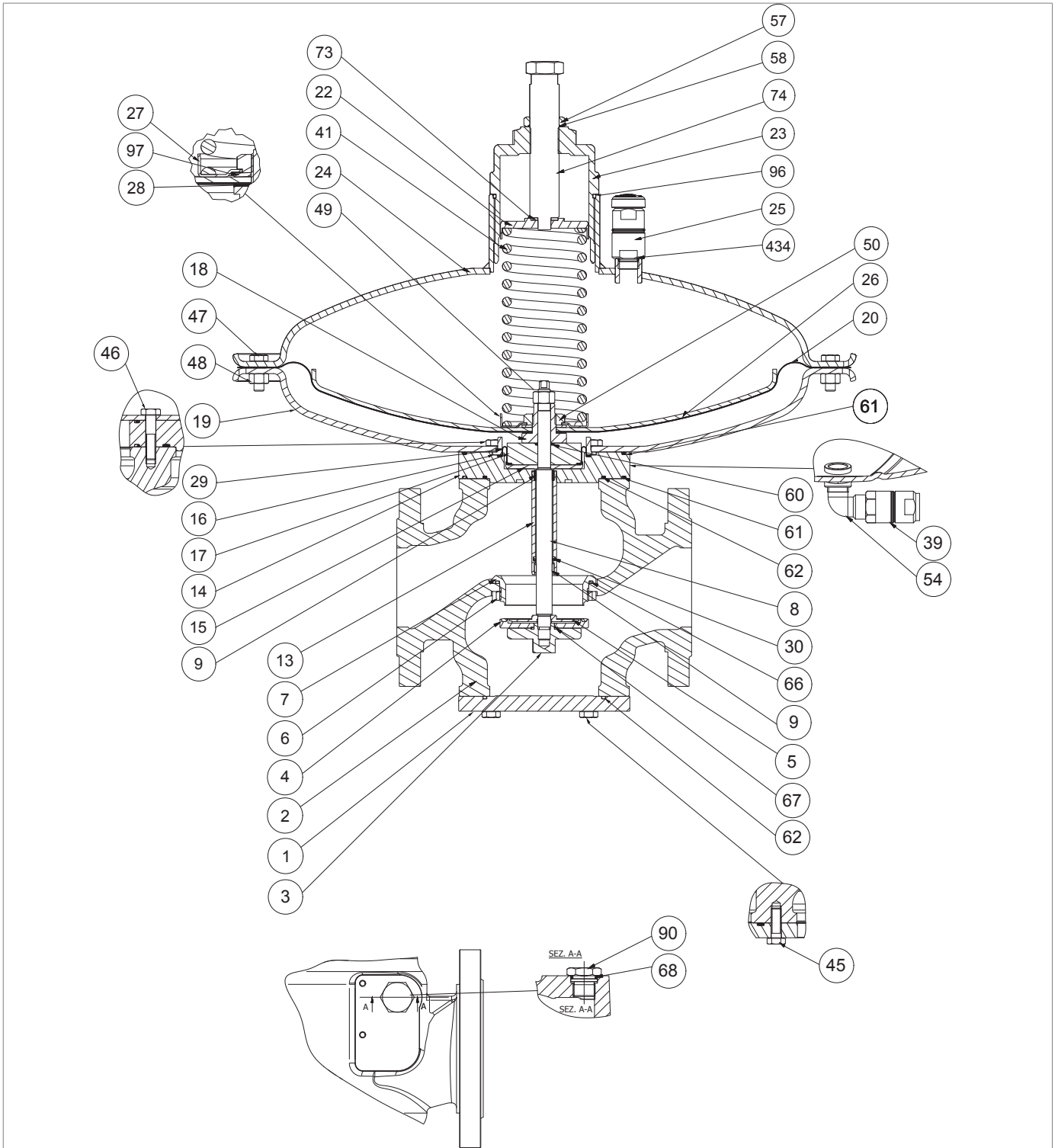

NORVAL Regulator 2" 1/2 - 3" (head 630)

Step	Action
57	<p>Insert and fix the screws (44) according to the following tightening torques:</p> <ul style="list-style-type: none"> • 2" 1/2: tab. 9.67 • 3": tab. 9.69 <div style="border: 1px solid black; padding: 5px;"> <p>! NOTICE!</p> <p>Tighten the screws according to the cross diagram in paragraph 9.4.2.2.</p> </div>
58	Position the spacer (17) together with the O-ring (60).
59	Place the diaphragm assembly (18, 20, 26, 27, 28, 50, 97) in the spacer (17).
60	Insert the rod (8) into the body (2) from the bottom upwards.
61	Align the holes of the main diaphragm (20) with the holes of the bottom cover (19).
62	<p>Insert the locking nut (49) according to the following tightening torques:</p> <ul style="list-style-type: none"> • 2" 1/2: tab. 9.67 • 3": tab. 9.69 <div style="border: 1px solid black; padding: 5px;"> <p>! NOTICE!</p> <p>During this phase, keep the rod (8) and the diaphragm support (18) still.</p> </div>
63	Fit the top cover (24).
64	Insert the screws (47) into the top cover (24) and bottom cover (19).
65	Insert the nuts (48) into the screws (47).
66	<p>Secure the screws (47) according to the following tightening torques:</p> <ul style="list-style-type: none"> • 2" 1/2: tab. 9.67 • 3": tab. 9.69 <div style="border: 1px solid black; padding: 5px;"> <p>! NOTICE!</p> <p>Tighten the screws according to the cross diagram in paragraph 9.4.2.2.</p> </div>
67	Insert the setting spring (41).
68	Insert the spring guide disc (22) together with the disc (73).
69	Insert and fix the cap (23).
70	Insert the adjustment screw (74) together with the O-ring (58) and the locking nut (44).
71	Insert and fasten the locking nut (57).
73	<p>Insert the locking nut (3) together with the reinforced gasket (4), the disc (5) and the O-ring (67) and secure them to the rod (8) from the bottom upwards, according to the following tightening torques:</p> <ul style="list-style-type: none"> • 2" 1/2: tab. 9.67 • 3": tab. 9.69
74	Fit the lower flange (1) together with the O-ring (62).
75	<p>Insert and fix the screws (45) according to the following tightening torques:</p> <ul style="list-style-type: none"> • 2" 1/2: tab. 9.67 • 3": tab. 9.69 <div style="border: 1px solid black; padding: 5px;"> <p>! NOTICE!</p> <p>Tighten the screws according to the cross diagram in paragraph 9.4.2.2.</p> </div>

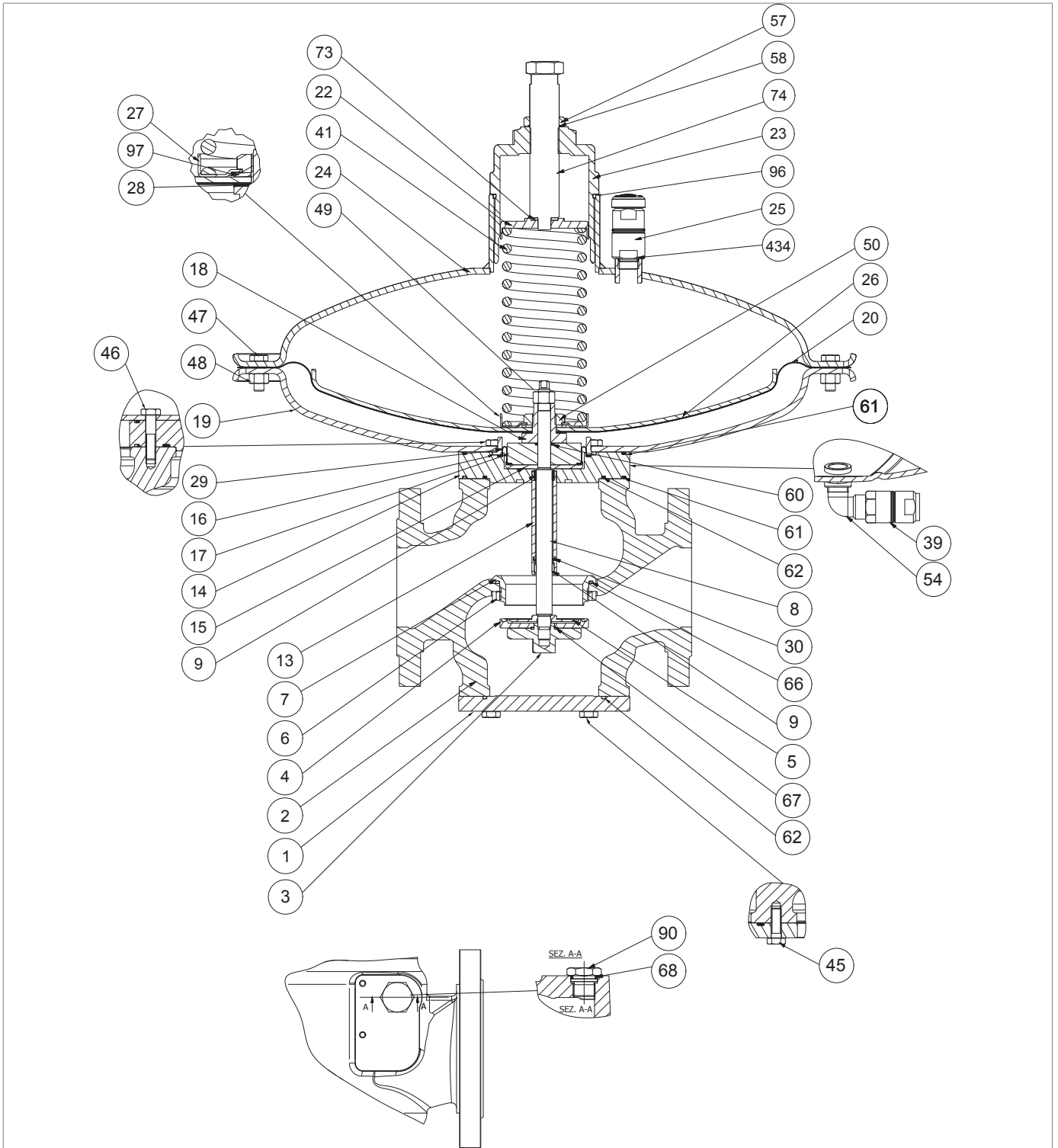

NORVAL Regulator 2" 1/2 - 3" (head 630)

Step	Action
76	Unscrew and remove the cap (90) together with the O-ring (68) from the front of the body (2).
77	Remove the O-ring (68) and replace it, taking care to lubricate it with synthetic grease. <div style="border: 1px solid black; padding: 5px; margin-top: 5px;">  NOTICE! Before inserting the replacement O-ring, clean the retaining slots with a cleaning solution. </div>
78	Position the cap (90) in the body (2).

Tab. 9.97.

 **WARNING!**

Ensure that all parts have been fitted correctly.

9.4.4.8 - NORVAL REGULATOR 4" (HEAD 375TR)

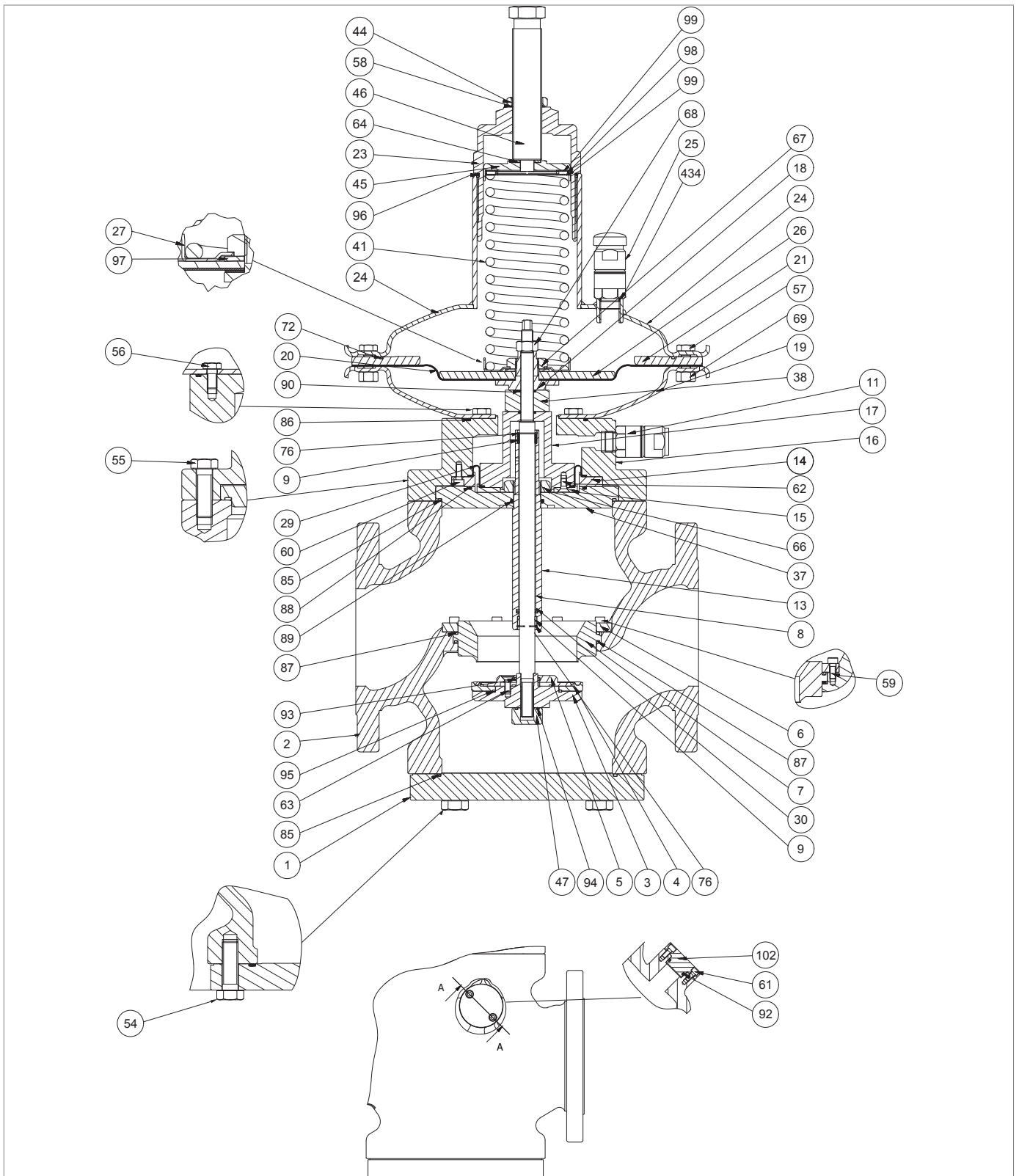
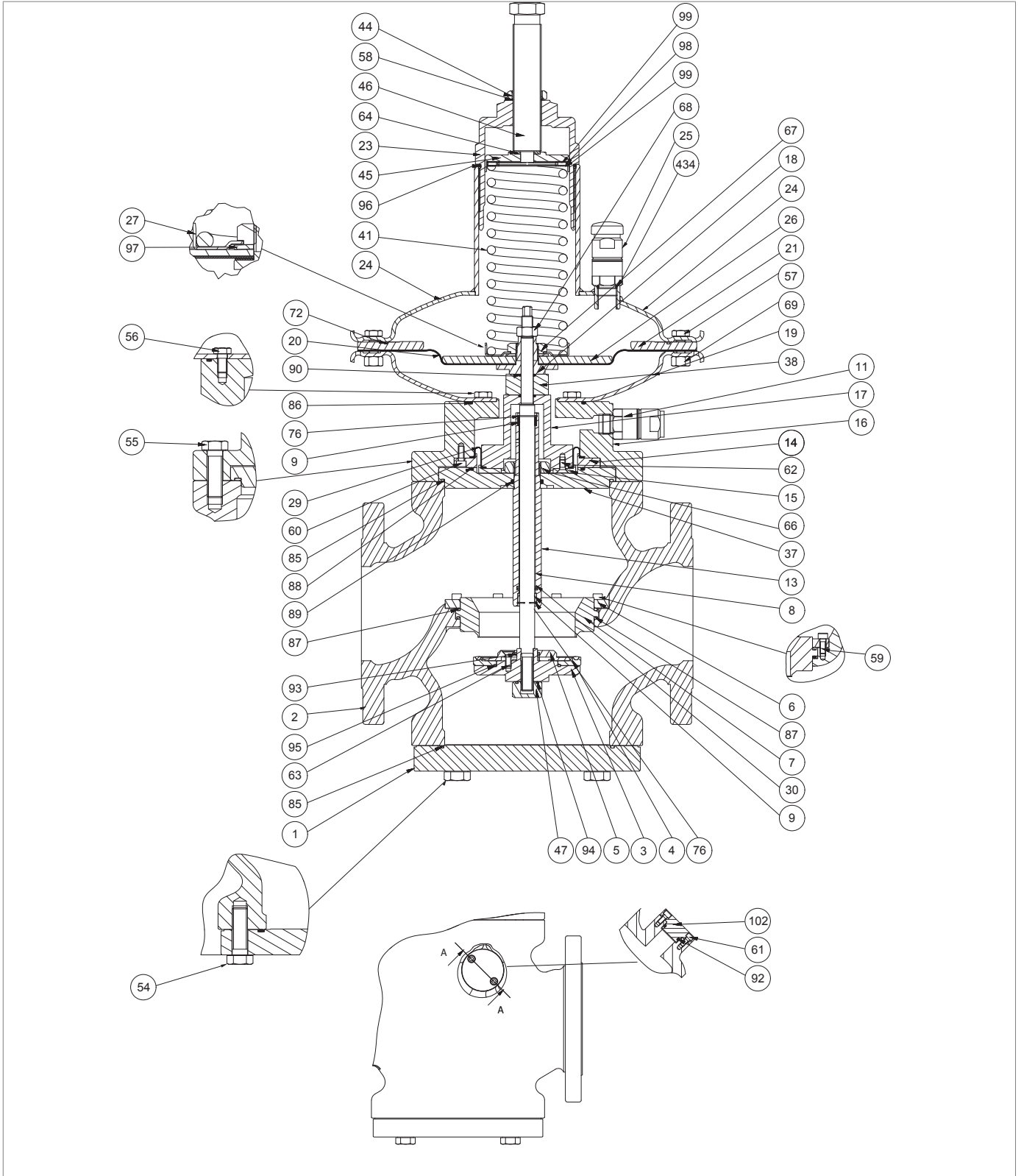

Fig. 9.41. NORVAL Regulator 4" (head 375TR)

Step	Action
1	Unscrew the lock nut (44).
2	Undo and remove the adjustment screw (46).
3	Remove the O-ring (58) from the lock nut (44) and replace it, taking care to lubricate it with synthetic grease. ! NOTICE! Before inserting the replacement O-ring, clean the retaining slots with a cleaning solution.
4	Unscrew and remove the cap (23).
5	Remove the O-ring (96) from the cap (23) and replace it, taking care to lubricate it with synthetic grease. ! NOTICE! Before inserting the replacement O-ring, clean the retaining slots with a cleaning solution.
6	Remove the spring guide disc (45) together with the disc (64).
7	Remove the slewing rings (99) and the roller bearing (98).
8	Remove the setting spring (41).
9	Unscrew and remove the anti-pumping valve (25) from the top cover (24).
10	Remove the O-ring (434) and replace it, taking care to lubricate it with synthetic grease. ! NOTICE! Before inserting the replacement O-ring, clean the retaining slots with a cleaning solution.
11	Position and secure the anti-pumping valve (25) in the top cover (24).
12	Undo and remove the screws (54).
13	Remove the lower flange (1). ! ATTENTION! In the presence of the ER device, refer to paragraph 9.4.5 for maintenance.
14	Remove the O-ring (85) and replace it, taking care to lubricate it with synthetic grease. ! NOTICE! Before inserting the replacement O-ring, clean the retaining slots with a cleaning solution.
15	Unscrew and remove the nut (47).
16	Remove the O-ring (94) and replace it, taking care to lubricate it with synthetic grease. ! NOTICE! Before inserting the replacement O-ring, clean the retaining slots with a cleaning solution.
17	Unscrew the adjustment assembly (3, 4, 5, 63, 93, 95) from the rod (8), and place it on a shockproof surface.
18	Undo and remove the screws (63).
19	Remove the protection disk (5) from the gasket support (3).
20	Remove the reinforced gasket (4) from the gasket support (3).
21	Remove the O-rings (93, 95) from the gasket support (3) and replace them, taking care to lubricate them with synthetic grease. ! NOTICE! Before inserting the replacement O-ring, clean the retaining slots with a cleaning solution.





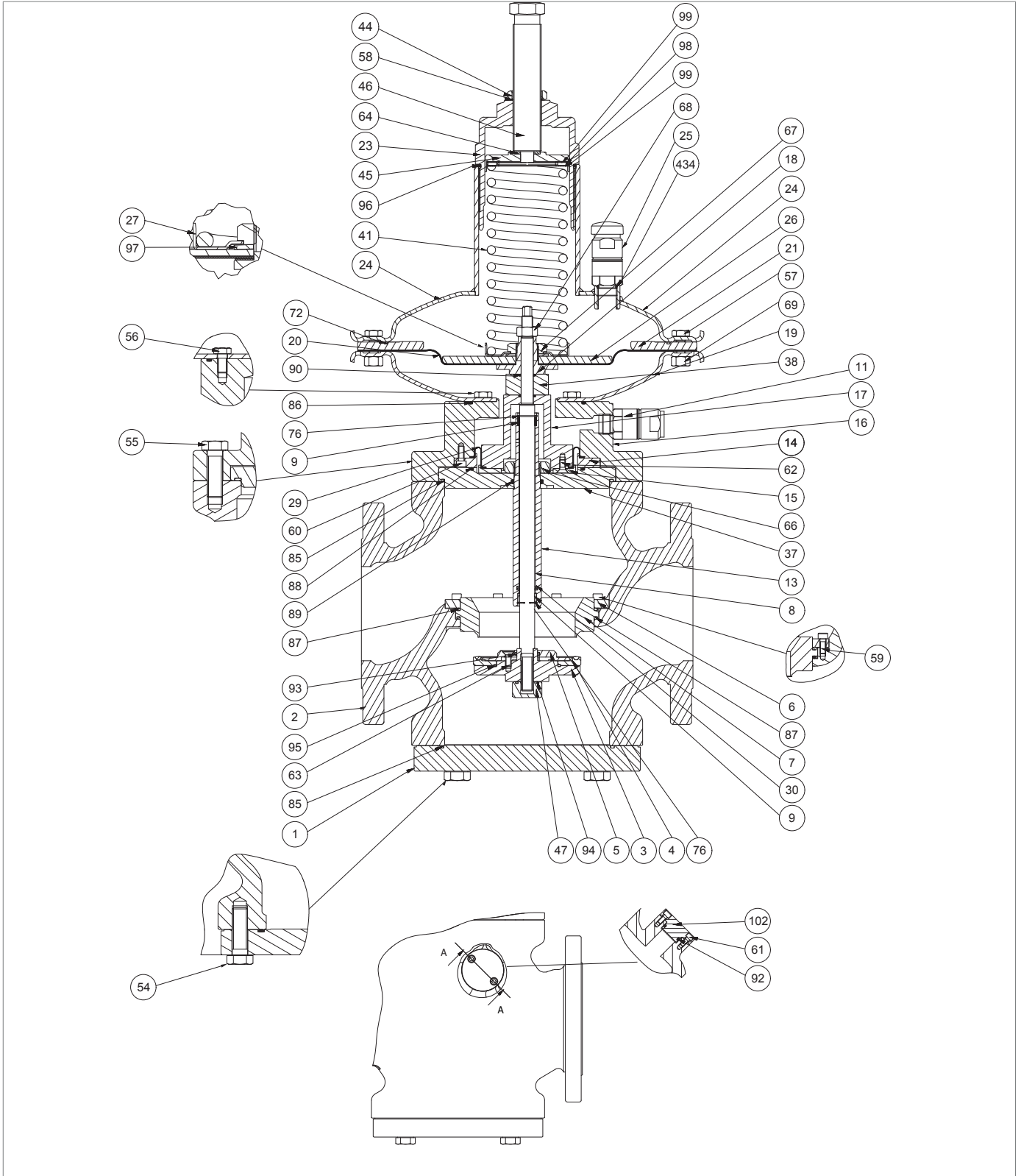

NORVAL Regulator 4" (head 375TR)

Step	Action
22	Replace the reinforced gasket (4).
23	Place the protection disc (5) in the gasket support (3).
24	Insert and fix the screws (63) according to the following tightening torques: <ul style="list-style-type: none"> • 4": tab. 9.70 <div style="border: 1px solid black; padding: 5px;">  NOTICE! Tighten the screws according to the cross diagram in paragraph 9.4.2.2. </div>
25	Undo and remove the screws (57) together with the nuts (69).
26	Remove the top cover (24).
27	Remove the reduction disc (21) together with the O-ring (72).
28	Remove the O-ring (72) and replace it, taking care to lubricate it with synthetic grease. <div style="border: 1px solid black; padding: 5px;">  NOTICE! Before inserting the replacement O-ring, clean the retaining slots with a cleaning solution. </div>
29	Unscrew and remove the locking nut (68). <div style="border: 1px solid black; padding: 5px;">  NOTICE! During this phase, keep the rod (8) still. </div>
30	Pull out the rod (8) from the top downwards.
31	Remove the diaphragm assembly (18, 26, 27, 28, 67, 97) placing it on a shockproof surface.
32	Remove the spacer (38) from the rod (8).
33	Unscrew and remove the nut (67). <div style="border: 1px solid black; padding: 5px;">  NOTICE! During this phase, keep the diaphragm support (18) still. </div>
34	Remove the spring guide disc (27) together with the spring washer (97).
35	Remove the protection disc (26).
36	Remove the diaphragm (20).
38	Fit the diaphragm (20).
39	Fit the protection disc (26).
40	Fit the spring washer (97).
41	Fit the spring guide disc (27).
42	Insert and fix the nut (67). <div style="border: 1px solid black; padding: 5px;">  NOTICE! During this phase, keep the diaphragm support (18) still. </div>
43	Undo and remove the screws (56).
44	Remove the bottom cover (19) from the intermediate body (16).
45	Undo and remove the screws (55).
46	Remove the intermediate body assembly (9, 11, 13, 15, 17, 29, 30, 37, 62, 66, 76, 85, 88, 89) placing it on a shockproof surface.







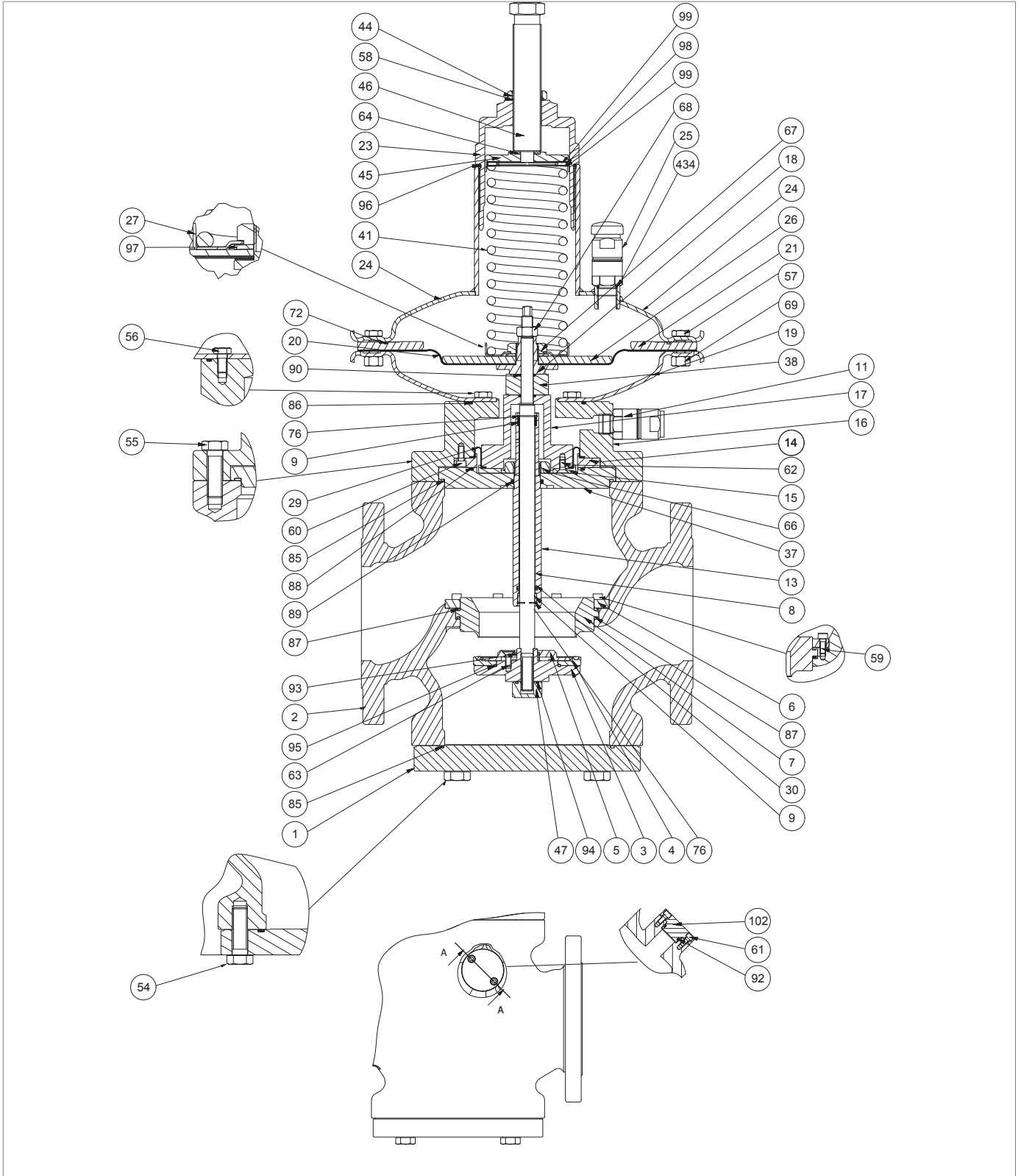

NORVAL Regulator 4" (head 375TR)

Step	Action
47	Pull out the flange (37), together with the rod guide sleeve (13), the nut (66), the O-rings (88, 89), the upper and lower circlips (76), the upper and lower I/DWR rings (9), and the lip seal (30) from the intermediate body (16).
48	Unscrew and remove the nut (66) from the rod guide sleeve (13).
49	Pull out the rod guide sleeve (13) from the flange spacer (37).  ATTENTION! In the presence of the SN slam-shut valve, see paragraph 9.4.6 for maintenance.
50	Remove the upper circlip (76).
51	Remove and replace the upper I/DWR ring (9).  NOTICE! Before inserting the replacement I/DWR ring, clean the retaining slots with a cleaning solution.
52	Fit the upper circlip (76).
53	Remove the lower circlip (76).
54	Remove the lower I/DWR ring (9).
55	Remove and replace the lip seal (30).
56	Replace the lower I/DWR ring (9).  NOTICE! Before inserting the replacement I/DWR ring, clean the retaining slots with a cleaning solution.
57	Fit the lower circlip (76).
58	Remove the O-rings (85, 88, 89) and replace them, taking care to lubricate them with synthetic grease.  NOTICE! Before inserting the replacement O-rings, clean the retaining slots with a cleaning solution.
59	Insert the rod guide sleeve (13) together with the upper I/DWR rings (9), the circlips (76), and the lip seal (30) into the flange (37).
60	Insert and fix the nut (66) according to the following tightening torques: <ul style="list-style-type: none"> • 4": tab. 9.70
61	Undo and remove the screws (60).
62	Remove the shaft collar (14) together with the screws (62), the balancing diaphragm (29), and the spacer (17) from the intermediate body (16).
63	Undo and remove the screws (62) of the spacer (17).
64	Remove the shaft collar (15).
65	Remove the balancing diaphragm (29) and replace it, taking care to lubricate it with synthetic grease.  NOTICE! Before inserting the replacement diaphragm, clean the retaining slots with a cleaning solution.
66	Fit the shaft collar (15).







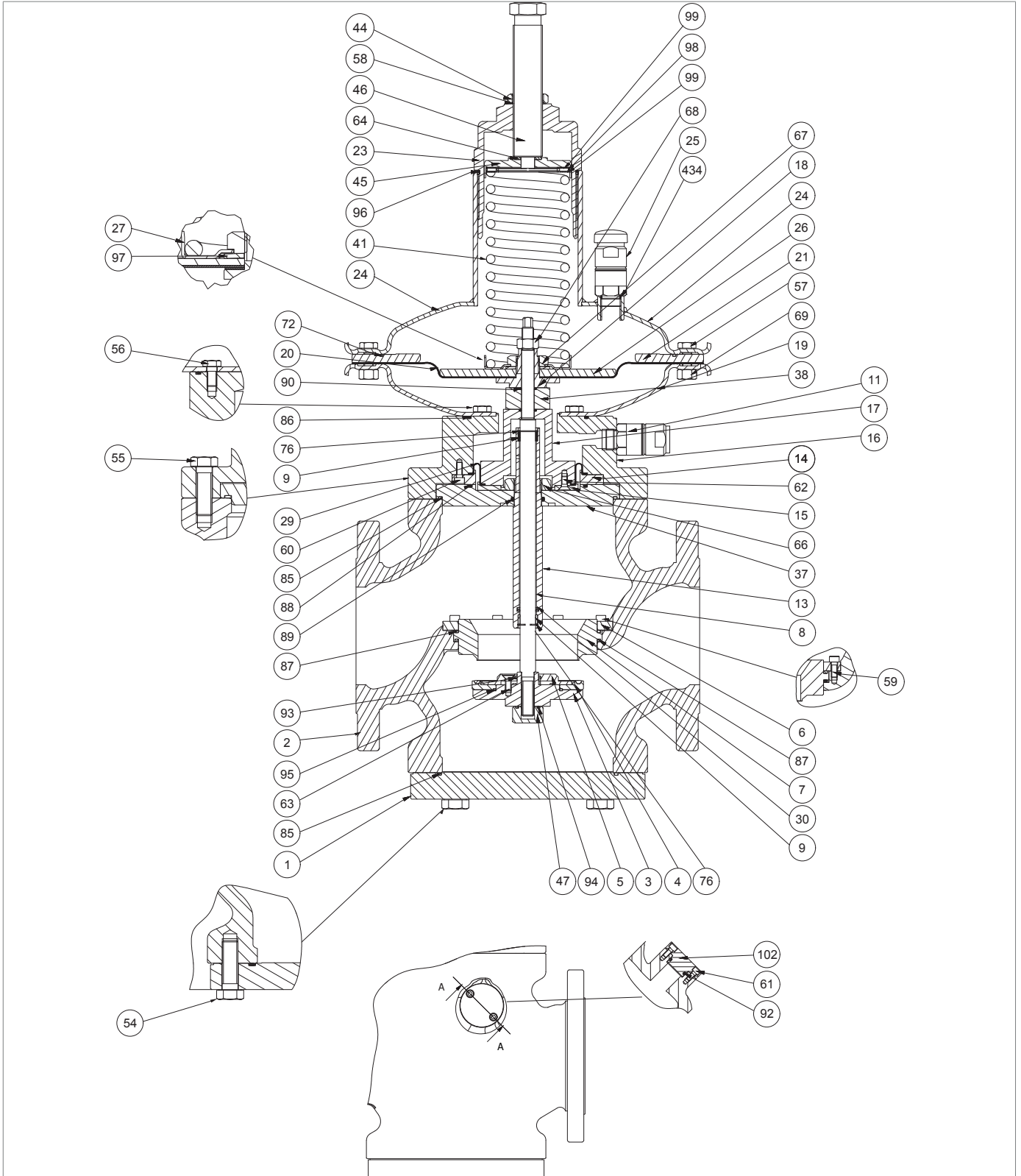

NORVAL Regulator 4" (head 375TR)

Step	Action
67	Insert and fix the screws (62) according to the following tightening torques: <ul style="list-style-type: none"> 4": tab. 9.70 <div style="border: 1px solid black; padding: 5px;">  NOTICE! </div> <p>Tighten the screws according to the cross diagram in paragraph 9.4.2.2.</p>
68	Fit the assembly (9, 11, 13, 15, 17, 29, 30, 37, 62, 66, 76, 85, 88, 89) into the intermediate body (16).
69	Insert and fix the screws (60) according to the following tightening torques: <ul style="list-style-type: none"> 4": tab. 9.70 <div style="border: 1px solid black; padding: 5px;">  NOTICE! </div> <p>Tighten the screws according to the cross diagram in paragraph 9.4.2.2.</p>
70	Fit the flange (37) into the intermediate body (16).
71	Undo and remove the screws (59).
72	Remove the shaft collar (6).
73	Pull out the valve seat (7) from the body (2).
74	Remove the O-rings (87) and replace them, taking care to lubricate them with synthetic grease. <div style="border: 1px solid black; padding: 5px;">  NOTICE! </div> <p>Before inserting the replacement O-rings, clean the retaining slots with a cleaning solution.</p>
75	Fit the valve seat (7) in the body (2).
76	Fit the shaft collar (6).
77	Insert and fix the screws (59) according to the following tightening torques: <ul style="list-style-type: none"> 4": tab. 9.70 <div style="border: 1px solid black; padding: 5px;">  NOTICE! </div> <p>Tighten the screws according to the cross diagram in paragraph 9.4.2.2.</p>
78	Fit the intermediate body (16) into the body (2).
79	Insert and fix the screws (55) according to the following tightening torques: <ul style="list-style-type: none"> 4": tab. 9.70 <div style="border: 1px solid black; padding: 5px;">  NOTICE! </div> <p>Tighten the screws according to the cross diagram in paragraph 9.4.2.2.</p>
80	Remove the O-ring (90) and replace it, taking care to lubricate it with synthetic grease. <div style="border: 1px solid black; padding: 5px;">  NOTICE! </div> <p>Before inserting the replacement O-ring, clean the retaining slots with a cleaning solution.</p>
81	Remove the O-ring (86) and replace it, taking care to lubricate it with synthetic grease. <div style="border: 1px solid black; padding: 5px;">  NOTICE! </div> <p>Before inserting the replacement O-ring, clean the retaining slots with a cleaning solution.</p>
82	Fit the bottom cover (19).



NORVAL Regulator 4" (head 375TR)

Step	Action
83	Insert and fix the screws (56) according to the following tightening torques: <ul style="list-style-type: none"> • 4": tab. 9.70 <div style="border: 1px solid black; padding: 5px;">  NOTICE! Tighten the screws according to the cross diagram in paragraph 9.4.2.2. </div>
84	Position the spacer (38).
85	Fit the diaphragm assembly (18, 26, 27, 28, 67, 97). <div style="border: 1px solid black; padding: 5px;">  NOTICE! Centre the diaphragm support hole (18) in the hole of the spacer (38). </div>
86	Insert the rod (8) into the rod guide sleeve (13) from the bottom upwards. <div style="border: 1px solid black; padding: 5px;">  NOTICE! <ul style="list-style-type: none"> • Align the hole of the spacer (38) to the diaphragm protection disc (26) • Clean and lubricate the rod (8) </div>
87	Position the protection disc (21) together with the O-ring (72).
88	Insert the lock nut (68). <div style="border: 1px solid black; padding: 5px;">  NOTICE! Align the housing of the rod fixing spanner (8) and the housing of the diaphragm support fixing spanner (18). </div>
89	Align the holes of the main diaphragm (20) with the holes of the bottom cover (19).
90	Fix the nut (68) according to the following tightening torques: <ul style="list-style-type: none"> • 4": tab. 9.70
91	Fit the top cover (24).
92	Insert and fix the screws (57) together with the nuts (69) according to the following tightening torques: <ul style="list-style-type: none"> • 4": tab. 9.70 <div style="border: 1px solid black; padding: 5px;">  NOTICE! Tighten the screws according to the cross diagram in paragraph 9.4.2.2. </div>
93	Screw the adjustment assembly (3, 4, 5, 63, 93, 95) into the rod (8) clockwise.
94	Insert and fix the nut (47) according to the following tightening torques: <ul style="list-style-type: none"> • 4": tab. 9.70
95	Fit the lower flange (1).
96	Insert and fix the screws (54) according to the following tightening torques: <ul style="list-style-type: none"> • 4": tab. 9.70 <div style="border: 1px solid black; padding: 5px;">  NOTICE! Tighten the screws according to the cross diagram in paragraph 9.4.2.2. </div>
99	Insert the regulation spring (41).
100	Position the slewing rings (99) and roller bearings (98).
101	Insert the spring guide (45) together with the disc (64).
102	Insert and fix the cap (23), together with the O-rings (58, 96), the lock nut (44) and the adjustment screw (46).

Tab. 9.98.



Ensure that all parts have been fitted correctly.

9.4.4.9 - NORVAL REGULATOR 4" (HEAD 375)

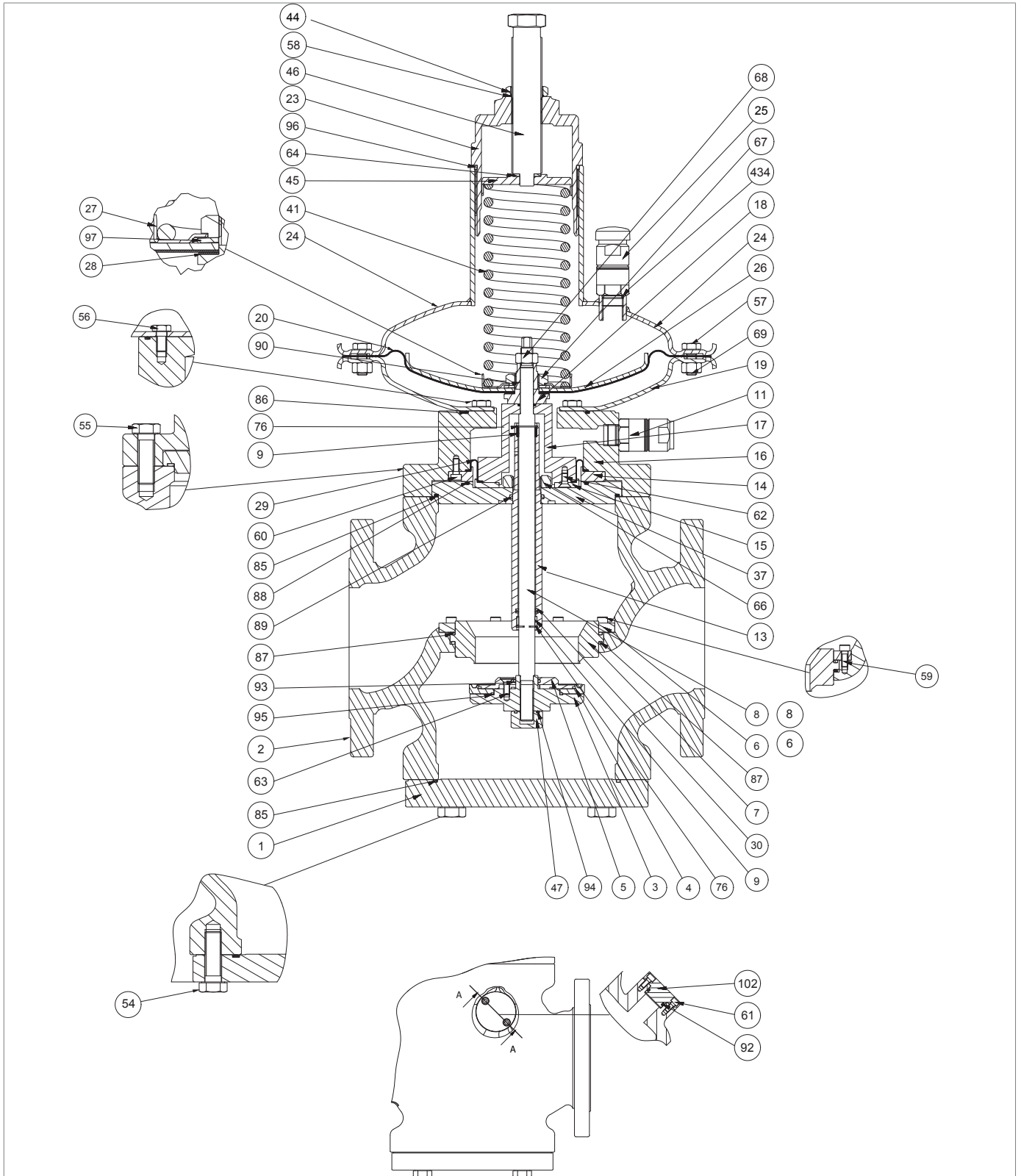
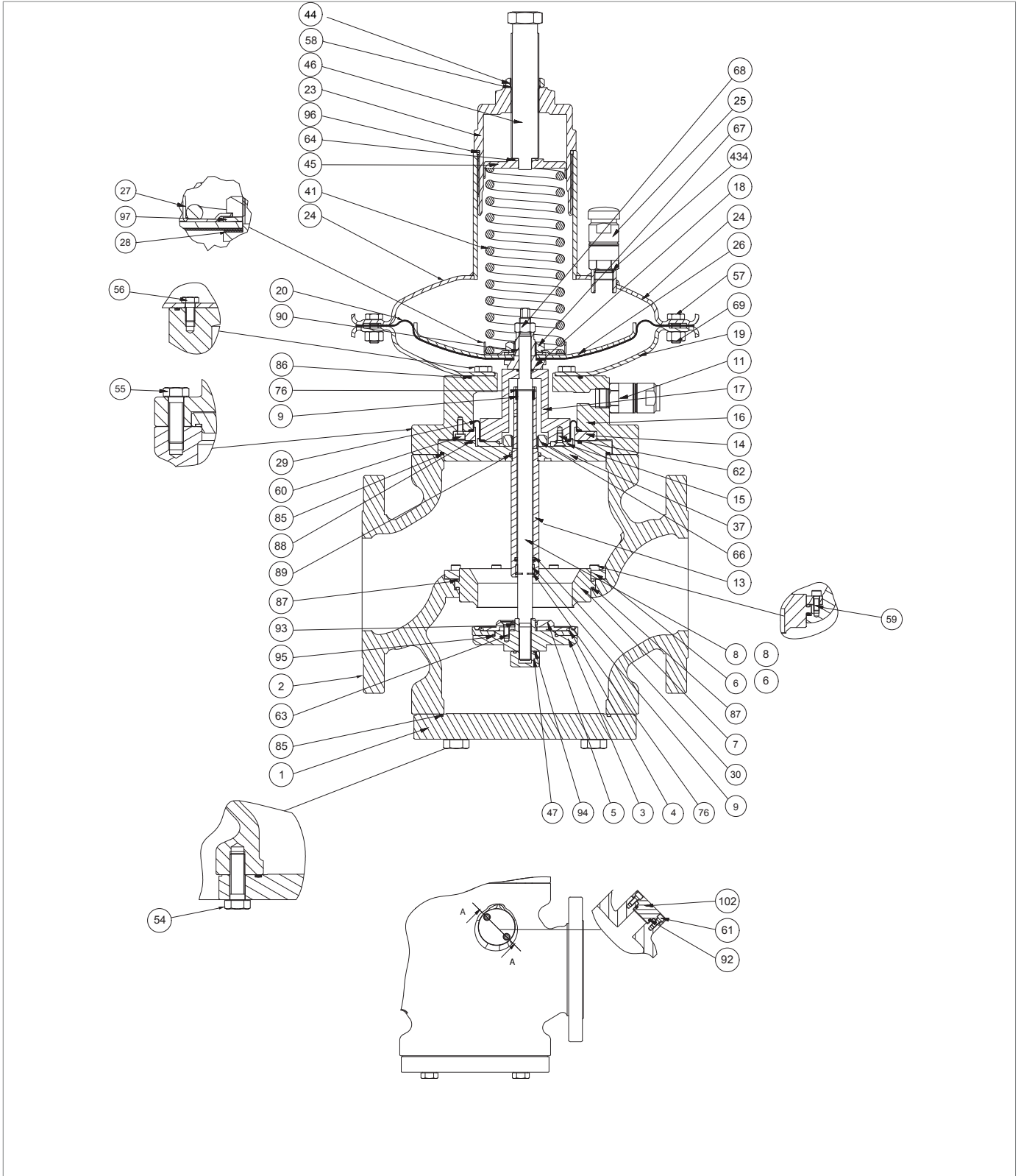

Fig. 9.42. NORVAL Regulator 4" (head 375)

Step	Action
1	Unscrew the nut (44).
2	Undo and remove the adjustment screw (46).
3	Remove the O-ring (58) and replace it, taking care to lubricate it with synthetic grease. <div style="border: 1px solid black; padding: 5px;">! NOTICE! Before inserting the replacement O-ring, clean the retaining slots with a cleaning solution.</div>
4	Unscrew and remove the cap (23)
5	Remove the O-ring (96) and replace it, taking care to lubricate it with synthetic grease. <div style="border: 1px solid black; padding: 5px;">! NOTICE! Before inserting the replacement O-ring, clean the retaining slots with a cleaning solution.</div>
6	Remove the spring guide disc (45) together with the disc (64).
7	Remove the slewing rings (99) and the roller bearing (98).
8	Remove the setting spring (41).
9	Unscrew and remove the anti-pumping valve (25) from the top cover (24).
10	Remove the O-ring (434) and replace it, taking care to lubricate it with synthetic grease. <div style="border: 1px solid black; padding: 5px;">! NOTICE! Before inserting the replacement O-ring, clean the retaining slots with a cleaning solution.</div>
11	Position and secure the anti-pumping valve (25) in the top cover (24).
12	Undo and remove the screws (54).
13	Remove the lower flange (1). <div style="background-color: yellow; padding: 5px;">! ATTENTION! In the presence of the ER device, refer to paragraph 9.4.5 for maintenance.</div>
14	Remove the O-ring (85) and replace it, taking care to lubricate it with synthetic grease. <div style="border: 1px solid black; padding: 5px;">! NOTICE! Before inserting the replacement O-ring, clean the retaining slots with a cleaning solution.</div>
15	Unscrew and remove the nut (47).
16	Remove the O-ring (94) and replace it, taking care to lubricate it with synthetic grease. <div style="border: 1px solid black; padding: 5px;">! NOTICE! Before inserting the replacement O-ring, clean the retaining slots with a cleaning solution.</div>
17	Unscrew the adjustment assembly (3, 4, 5, 63, 93, 95) from the rod (8), and place it on a shockproof surface.
18	Undo and remove the screws (63).
19	Remove the protection disk (5) from the gasket support (3).
20	Remove the reinforced gasket (4) from the gasket support (3).
21	Remove the O-rings (93, 95) from the gasket support (3) and replace them, taking care to lubricate them with synthetic grease. <div style="border: 1px solid black; padding: 5px;">! NOTICE! Before inserting the replacement O-ring, clean the retaining slots with a cleaning solution.</div>





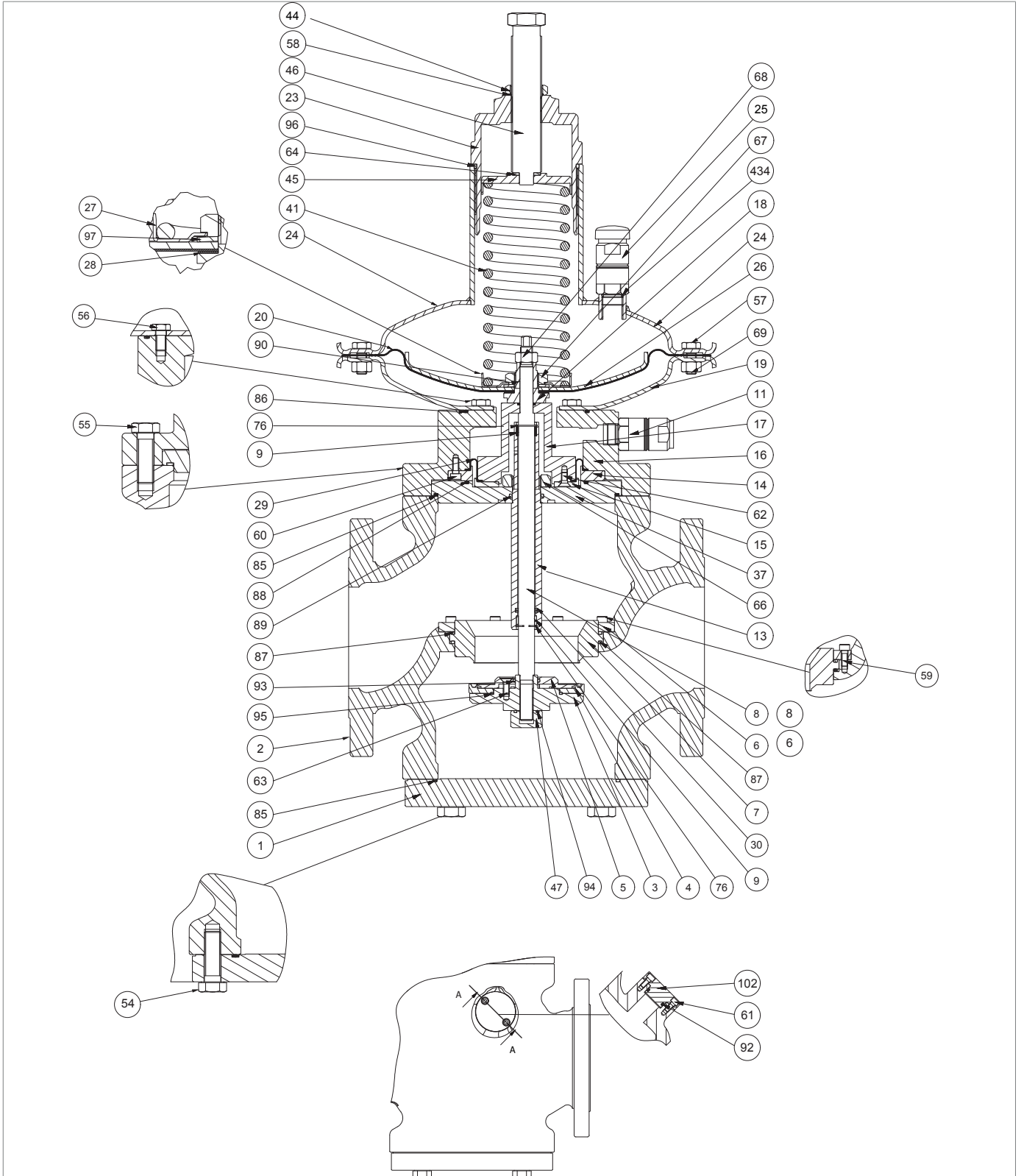

NORVAL Regulator 4" (head 375)

Step	Action
22	Replace the reinforced gasket (4).
23	Place the protection disc (5) in the gasket support (3).
24	<p>Insert and fix the screws (63) according to the following tightening torques:</p> <ul style="list-style-type: none"> • 4": tab. 9.70 <div style="border: 1px solid blue; padding: 5px;"> <p>! NOTICE!</p> <p>Tighten the screws according to the cross diagram in paragraph 9.4.2.2.</p> </div>
25	Undo and remove the screws (57) together with the nuts (69).
26	Remove the top cover (24).
27	Remove the reduction disc (21) together with the O-ring (72).
28	<p>Remove the O-ring (72) and replace it, taking care to lubricate it with synthetic grease.</p> <div style="border: 1px solid blue; padding: 5px;"> <p>! NOTICE!</p> <p>Before inserting the replacement O-ring, clean the retaining slots with a cleaning solution.</p> </div>
29	<p>Unscrew and remove the locking nut (68).</p> <div style="border: 1px solid blue; padding: 5px;"> <p>! NOTICE!</p> <p>During this phase, keep the rod (8) still.</p> </div>
30	Pull out the rod (8) from the top downwards.
31	Remove the diaphragm assembly (18, 26, 27, 28, 67, 97) placing it on a shockproof surface.
32	Remove the spacer (38) from the rod (8).
33	<p>Unscrew and remove the nut (67).</p> <div style="border: 1px solid blue; padding: 5px;"> <p>! NOTICE!</p> <p>During this phase, keep the diaphragm support (18) still.</p> </div>
34	Remove the spring guide disc (27) together with the spring washer (97).
35	Remove the protection disc (26).
36	Remove the diaphragm (20).
37	Remove the oil seal (28) and replace it.
38	Fit the diaphragm (20).
39	Fit the protection disc (26).
40	Fit the spring washer (97).
41	Fit the spring guide disc (27).
42	<p>Insert and fix the nut (67).</p> <div style="border: 1px solid blue; padding: 5px;"> <p>! NOTICE!</p> <p>During this phase, keep the diaphragm support (18) still.</p> </div>
43	Undo and remove the screws (56).
44	Remove the bottom cover (19) from the intermediate body (16).
45	Undo and remove the screws (55).
46	Remove the intermediate body assembly (9, 11, 13, 15, 17, 29, 30, 37, 62, 66, 76, 85, 88, 89) placing it on a shockproof surface.



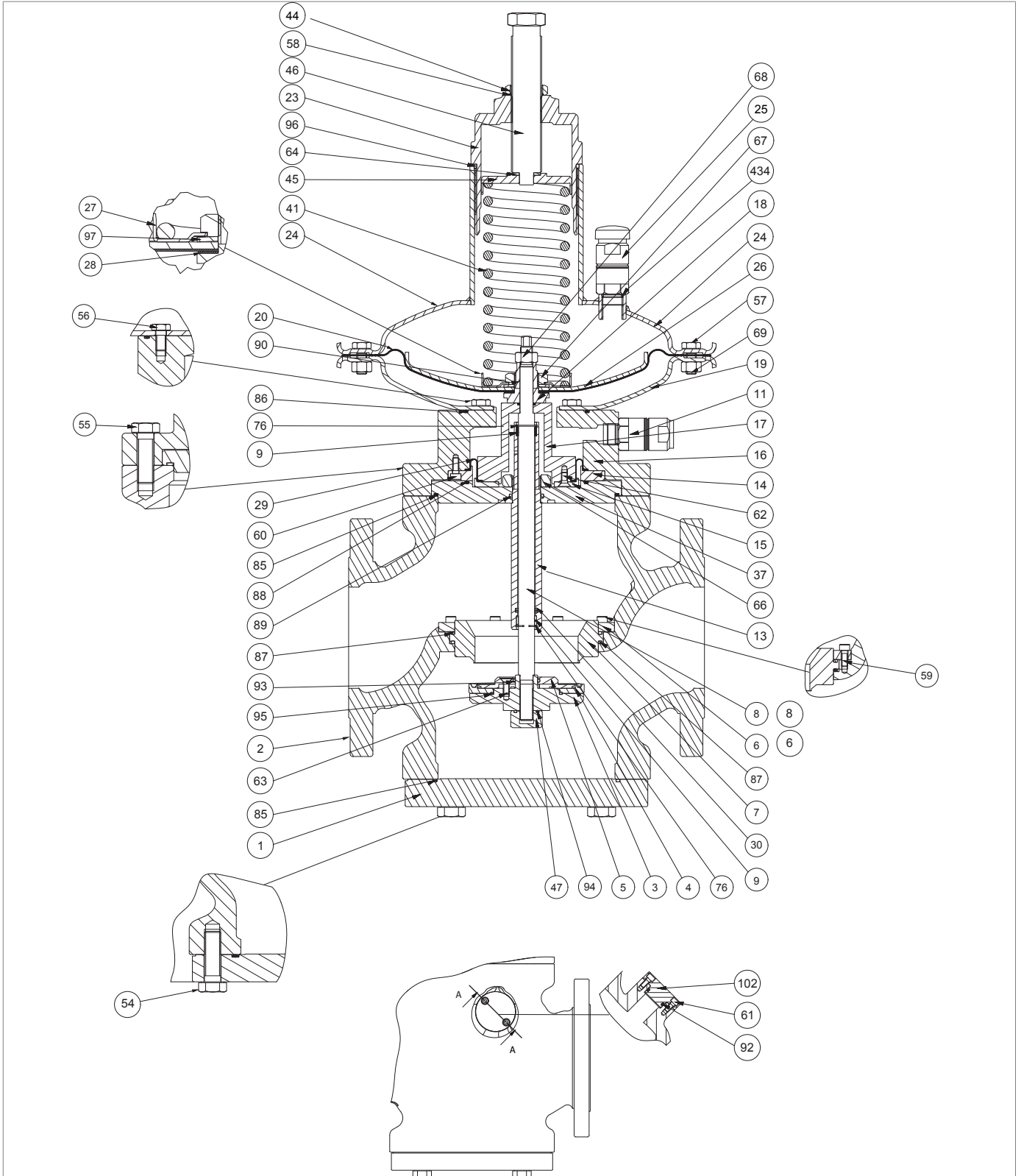

NORVAL Regulator 4" (head 375)

Step	Action
47	Pull out the flange (37), together with the rod guide sleeve (13), the nut (66), the O-rings (88, 89), the upper and lower circlips (76), the upper and lower I/DWR rings (9), and the lip seal (30) from the intermediate body (16).
48	Unscrew and remove the nut (66) from the rod guide sleeve (13).
49	Pull out the rod guide sleeve (13) from the flange spacer (37).  ATTENTION! In the presence of the SN slam-shut valve, see paragraph 9.4.6 for maintenance.
50	Remove the upper circlip (76).
51	Remove and replace the upper I/DWR ring (9).  NOTICE! Before inserting the replacement I/DWR ring, clean the retaining slots with a cleaning solution.
52	Fit the upper circlip (76).
53	Remove the lower circlip (76).
54	Remove the lower I/DWR ring (9).
55	Remove and replace the lip seal (30).
56	Replace the lower I/DWR ring (9).  NOTICE! Before inserting the replacement I/DWR ring, clean the retaining slots with a cleaning solution.
57	Fit the lower circlip (76).
58	Remove the O-rings (85, 88, 89) and replace them, taking care to lubricate them with synthetic grease.  NOTICE! Before inserting the replacement O-rings, clean the retaining slots with a cleaning solution.
59	Insert the rod guide sleeve (13) together with the upper I/DWR rings (9), the circlips (76), and the lip seal (30) into the flange (37).
60	Insert and fix the nut (66) according to the following tightening torques: <ul style="list-style-type: none"> • 4": tab. 9.70
61	Undo and remove the screws (60).
62	Remove the shaft collar (14) together with the screws (62), the balancing diaphragm (29), and the spacer (17) from the intermediate body (16).
63	Undo and remove the screws (62) of the spacer (17).
64	Remove the shaft collar (15).
65	Remove the balancing diaphragm (29) and replace it, taking care to lubricate it with synthetic grease.  NOTICE! Before inserting the replacement diaphragm, clean the retaining slots with a cleaning solution.
66	Fit the shaft collar (15).



NORVAL Regulator 4" (head 375)

Step	Action
67	Insert and fix the screws (62) according to the following tightening torques: <ul style="list-style-type: none"> • 4": tab. 9.70 <div style="border: 1px solid black; padding: 5px;">  NOTICE! </div> <p>Tighten the screws according to the cross diagram in paragraph 9.4.2.2.</p>
68	Fit the assembly (9, 11, 13, 15, 17, 29, 30, 37, 62, 66, 76, 85, 88, 89) into the intermediate body (16).
69	Insert and fix the screws (60) according to the following tightening torques: <ul style="list-style-type: none"> • 4": tab. 9.70 <div style="border: 1px solid black; padding: 5px;">  NOTICE! </div> <p>Tighten the screws according to the cross diagram in paragraph 9.4.2.2.</p>
70	Fit the flange (37) into the intermediate body (16).
71	Undo and remove the screws (59).
72	Remove the shaft collar (6).
73	Pull out the valve seat (7) from the body (2).
74	Remove the O-rings (87) and replace them, taking care to lubricate them with synthetic grease. <div style="border: 1px solid black; padding: 5px;">  NOTICE! </div> <p>Before inserting the replacement O-rings, clean the retaining slots with a cleaning solution.</p>
75	Fit the valve seat (7) in the body (2).
76	Fit the shaft collar (6).
77	Insert and fix the screws (59) according to the following tightening torques: <ul style="list-style-type: none"> • 4": tab. 9.70 <div style="border: 1px solid black; padding: 5px;">  NOTICE! </div> <p>Tighten the screws according to the cross diagram in paragraph 9.4.2.2.</p>
78	Fit the intermediate body (16) into the body (2).
79	Insert and fix the screws (55) according to the following tightening torques: <ul style="list-style-type: none"> • 4": tab. 9.70 <div style="border: 1px solid black; padding: 5px;">  NOTICE! </div> <p>Tighten the screws according to the cross diagram in paragraph 9.4.2.2.</p>
80	Remove the O-ring (90) and replace it, taking care to lubricate it with synthetic grease. <div style="border: 1px solid black; padding: 5px;">  NOTICE! </div> <p>Before inserting the replacement O-ring, clean the retaining slots with a cleaning solution.</p>
81	Remove the O-ring (86) and replace it, taking care to lubricate it with synthetic grease. <div style="border: 1px solid black; padding: 5px;">  NOTICE! </div> <p>Before inserting the replacement O-ring, clean the retaining slots with a cleaning solution.</p>
82	Fit the bottom cover (19).
83	Insert and fix the screws (56) according to the following tightening torques: <ul style="list-style-type: none"> • 4": tab. 9.70 <div style="border: 1px solid black; padding: 5px;">  NOTICE! </div> <p>Tighten the screws according to the cross diagram in paragraph 9.4.2.2.</p>

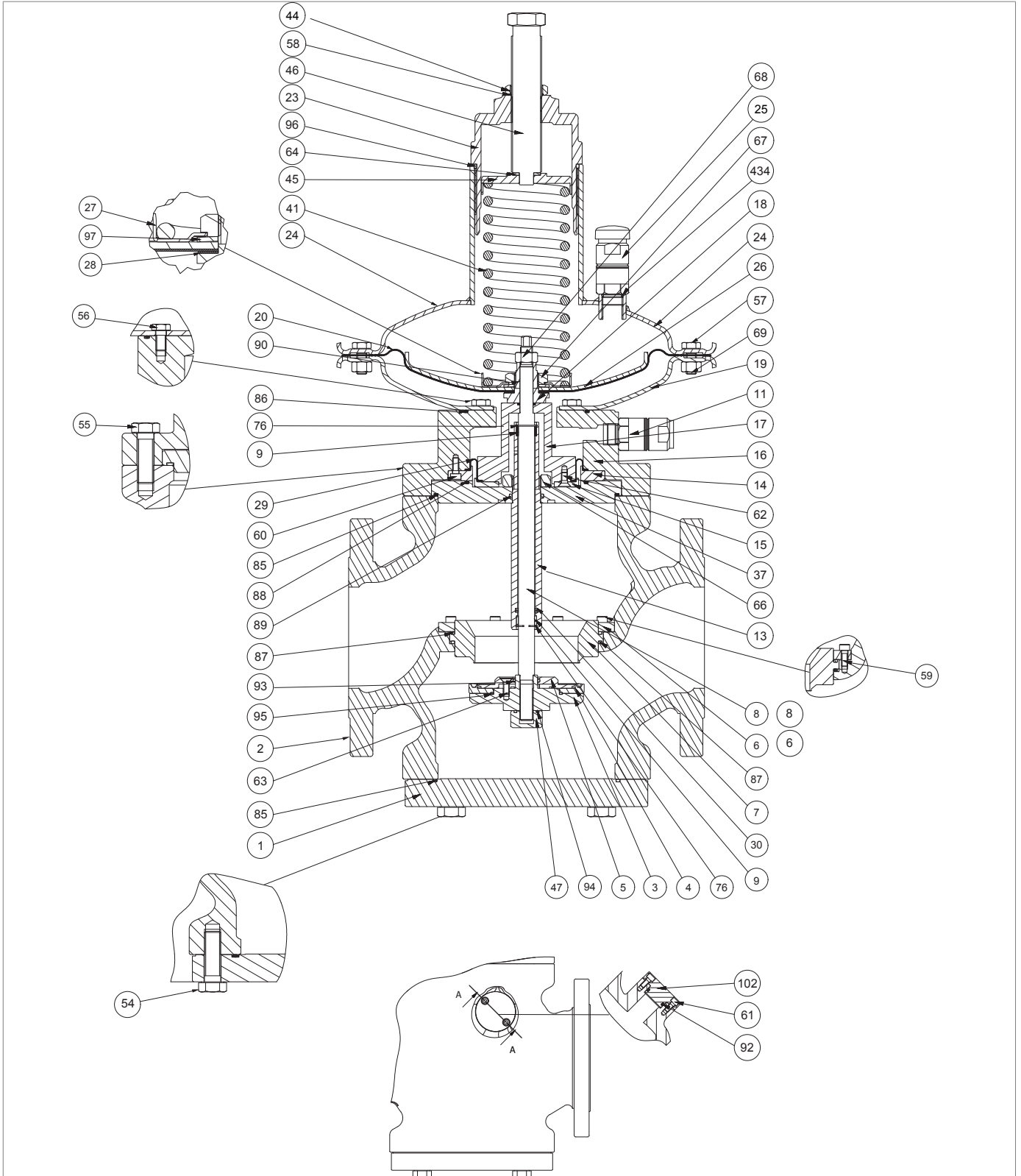

NORVAL Regulator 4" (head 375)

Step	Action
84	Position the spacer (38).
85	Fit the diaphragm assembly (18, 26, 27, 28, 67, 97). NOTICE! Centre the diaphragm support hole (18) in the hole of the spacer (38).
86	Insert the rod (8) into the rod guide sleeve (13) from the bottom upwards. NOTICE! <ul style="list-style-type: none"> Align the hole of the spacer (38) to the diaphragm protection disc (26) Clean and lubricate the rod (8)
87	Position the protection disc (21) together with the O-ring (72).
88	Insert the lock nut (68). NOTICE! Align the housing of the rod fixing spanner (8) and the housing of the diaphragm support fixing spanner (18).
89	Align the holes of the main diaphragm (20) with the holes of the bottom cover (19).
90	Fix the nut (68) according to the following tightening torques: <ul style="list-style-type: none"> 4": tab. 9.70
91	Fit the top cover (24).
92	Insert and fix the screws (57) together with the nuts (69) according to the following tightening torques: <ul style="list-style-type: none"> 4": tab. 9.70 NOTICE! Tighten the screws according to the cross diagram in paragraph 9.4.2.2.
93	Screw the adjustment assembly (3, 4, 5, 63, 93, 95) into the rod (8) clockwise.
94	Insert and fix the nut (47) according to the following tightening torques: <ul style="list-style-type: none"> 4": tab. 9.70
95	Fit the lower flange (1).
96	Insert and fix the screws (54) according to the following tightening torques: <ul style="list-style-type: none"> 4": tab. 9.70 NOTICE! Tighten the screws according to the cross diagram in paragraph 9.4.2.2.
99	Insert the regulation spring (41).
100	Position the slewing rings (99) and roller bearings (98).
101	Insert the spring guide (45) together with the disc (64).
102	Insert and fix the cap (23), together with the O-rings (58, 96), the lock nut (44) and the adjustment screw (46).

Tab. 9.99.

! WARNING!

Ensure that all parts have been fitted correctly.

9.4.4.10 - NORVAL REGULATOR 4" (HEAD 495)

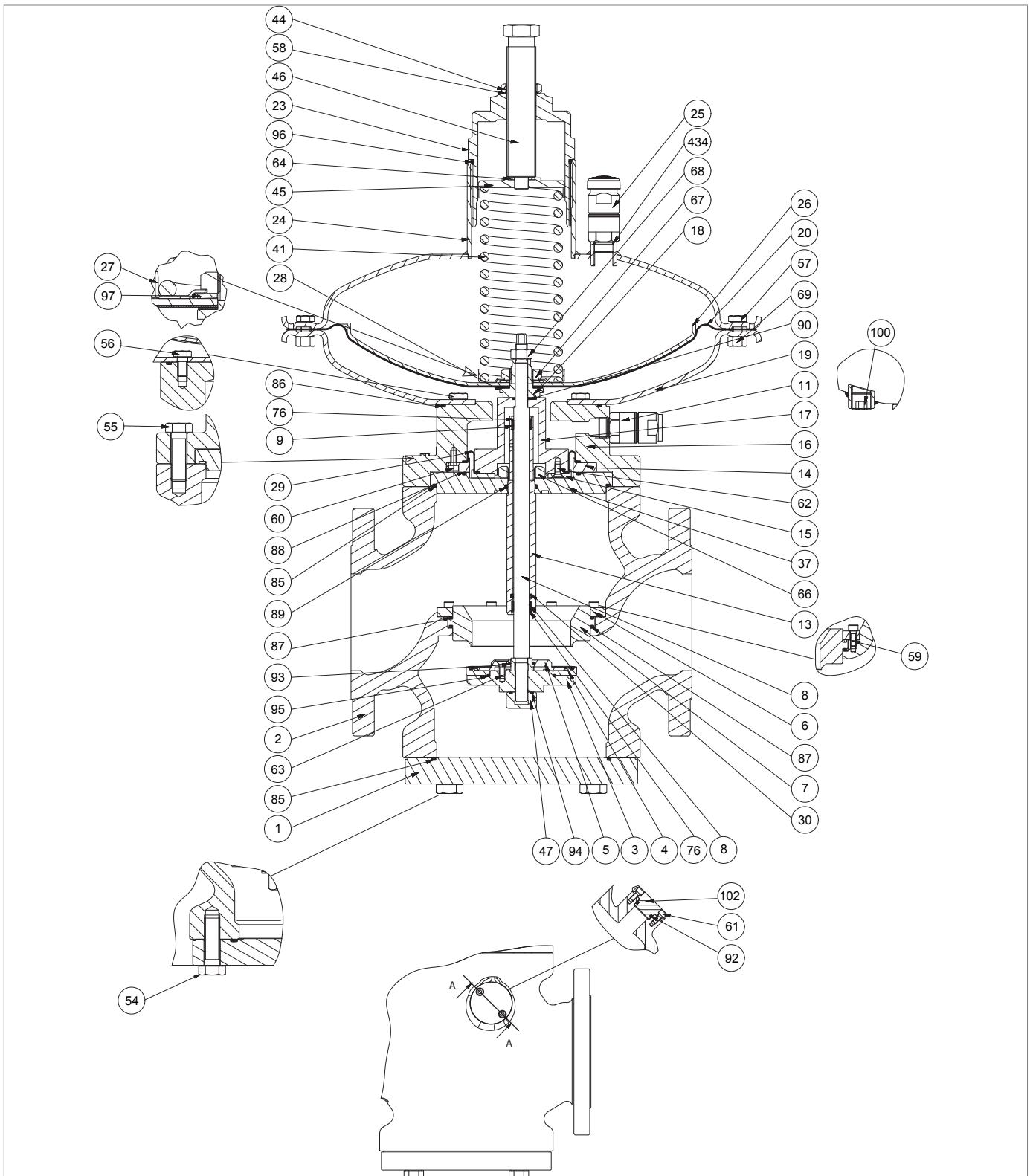





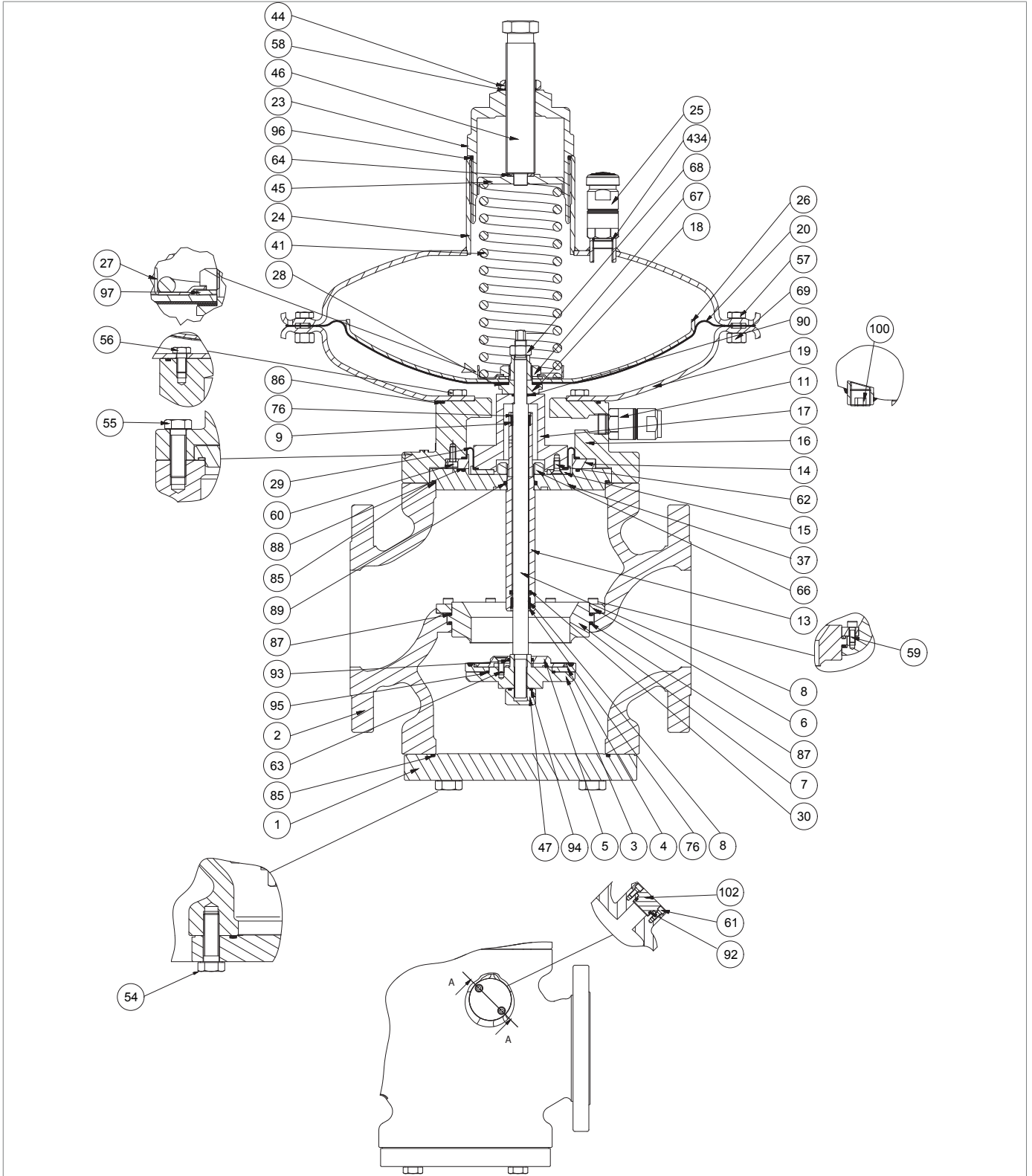

Fig. 9.43. NORVAL Regulator 4" (head 495)

Step	Action
1	Unscrew the lock nut (44).
2	Undo and remove the adjustment screw (46).
3	Remove the O-ring (58) and replace it, taking care to lubricate it with synthetic grease.  NOTICE! Before inserting the replacement O-ring, clean the retaining slots with a cleaning solution.
4	Unscrew and remove the cap (23).
5	Remove the O-ring (96) and replace it, taking care to lubricate it with synthetic grease.  NOTICE! Before inserting the replacement O-ring, clean the retaining slots with a cleaning solution.
6	Remove the spring guide disc (45) together with the disc (64).
7	Remove the setting spring (41).
8	Unscrew and remove the anti-pumping valve (25) from the top cover (24).
9	Remove the O-ring (434) and replace it, taking care to lubricate it with synthetic grease.  NOTICE! Before inserting the replacement O-ring, clean the retaining slots with a cleaning solution.
10	Position and secure the anti-pumping valve (25) in the top cover (24).
11	Undo and remove the screws (54).
12	Remove the lower flange (1).  ATTENTION! In the presence of the ER device, refer to paragraph 9.4.5 for maintenance.
13	Remove the O-ring (85) and replace it, taking care to lubricate it with synthetic grease.  NOTICE! Before inserting the replacement O-ring, clean the retaining slots with a cleaning solution.
14	Unscrew and remove the nut (47).
15	Remove the O-ring (94) and replace it, taking care to lubricate it with synthetic grease.  NOTICE! Before inserting the replacement O-ring, clean the retaining slots with a cleaning solution.
16	Unscrew the adjustment assembly (3, 4, 5, 63, 93, 95) from the rod (8) anti-clockwise.
17	Undo and remove the screws (63).
18	Remove the protection disk (5) from the gasket support (3).
19	Remove the reinforced gasket (4) from the gasket support (3).



NORVAL Regulator 4" (head 495)

Step	Action
20	Remove the O-rings (93, 95) from the gasket support (3) and replace them, taking care to lubricate them with synthetic grease. NOTICE! Before inserting the replacement O-rings, clean the retaining slots with a cleaning solution.
21	Replace the reinforced gasket (4).
22	Place the protection disc (5) in the gasket support (3).
23	Insert and fix the screws (63) according to the following tightening torques: • 4": tab. 9.87 NOTICE! Tighten the screws according to the cross diagram in paragraph 9.4.2.2.
24	Undo and remove the screws (57) together with the nuts (69).
25	Remove the top cover (24).
26	Unscrew and remove the locking nut (68).
27	Pull out the rod (8) from the top downwards.
28	Remove the diaphragm assembly (18, 20, 26, 27, 28, 67, 97) placing it on a shockproof surface.
29	Unscrew and remove the nut (67). NOTICE! During this phase, keep the diaphragm support (18) still.
30	Remove the spring guide disc (27) together with the circlip (97).
31	Remove the protection discs (26).
32	Remove the diaphragm (20).
33	Remove the oil seal (28) and replace it.
34	Fit the diaphragm (20).
35	Fit the protection discs (26).
36	Fit the spring washer (97).
37	Fit the spring guide disc (27).
38	Insert and fix the nut (67) according to the following tightening torques: • 4": tab. 9.70 NOTICE! During this phase, keep the diaphragm support (18) still.
39	Undo and remove the screws (56).
40	Remove the bottom cover (19) from the intermediate body (16).
41	Undo and remove the screws (55).
42	Remove the intermediate body assembly (9, 11, 13, 15, 17, 29, 30, 37, 62, 66, 76, 85, 88, 89).
43	Pull out the flange (37), together with the rod guide sleeve (13), the nut (66), the O-rings (85, 88, 89), the upper and lower circlips (76), the upper and lower I/DWR rings (9), and the lip seal (30) from the intermediate body (16). ATTENTION! In the presence of the SN slam-shut valve, see paragraph 9.4.6 for maintenance.

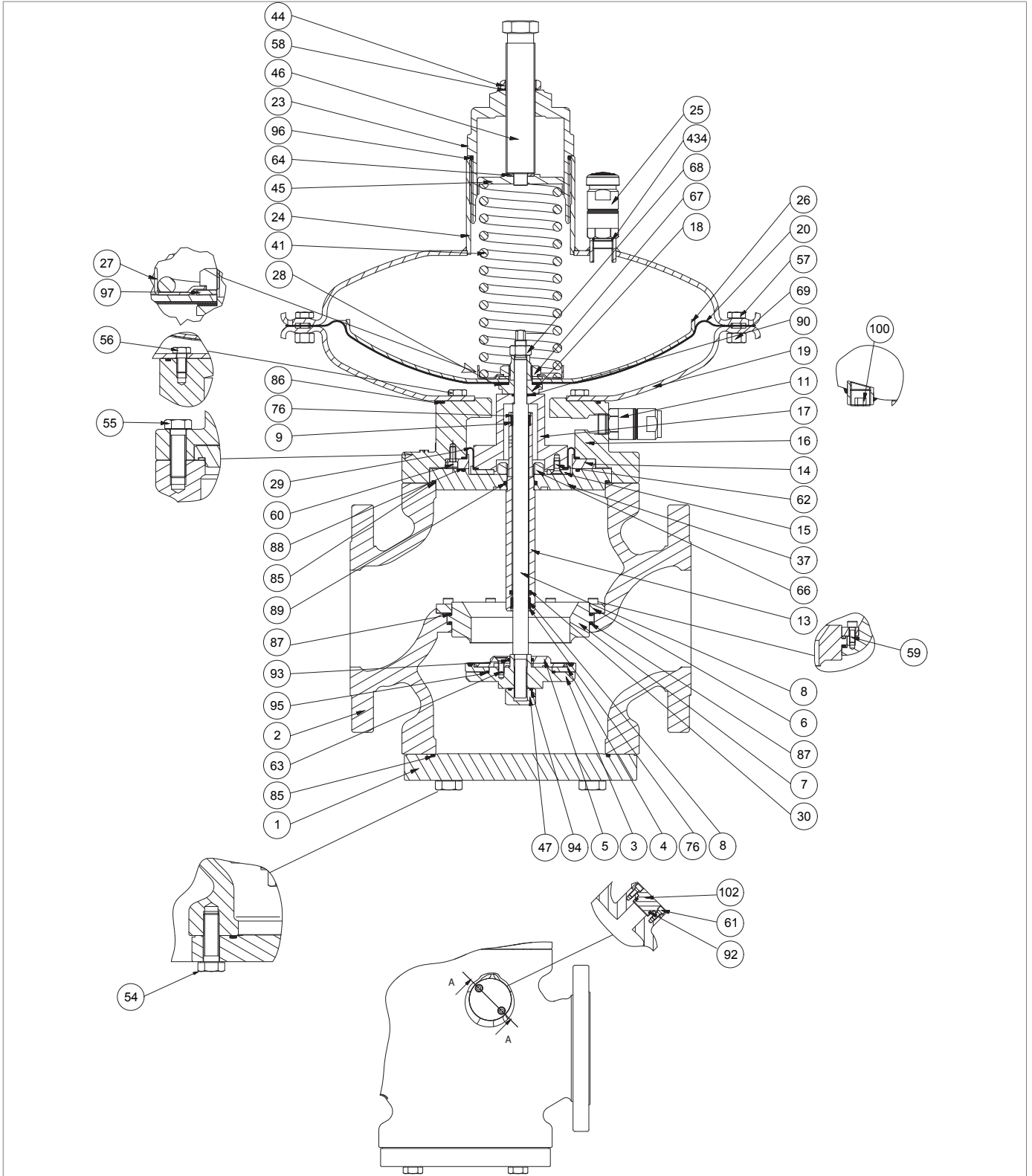





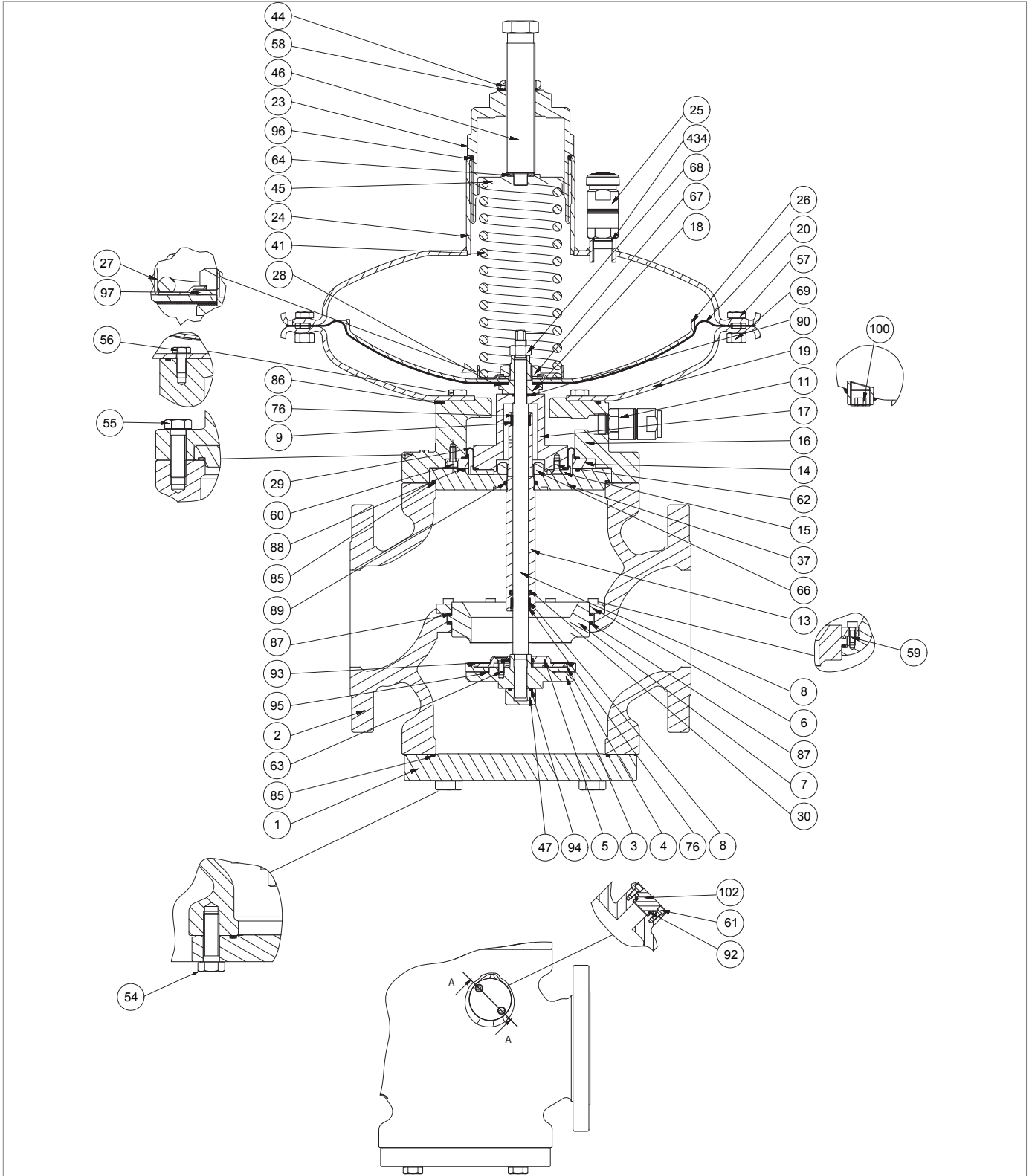

NORVAL Regulator 4" (head 495)

Step	Action
44	Unscrew and remove the nut (66) from the rod guide sleeve (13).
45	Pull out the rod guide sleeve (13) from the flange spacer (37).
46	Remove the upper circlip (76)
47	Remove and replace the upper I/DWR ring (9). NOTICE! Before inserting the replacement I/DWR ring, clean the retaining slots with a cleaning solution.
48	Fit the upper circlip (76).
49	Remove the lower circlip (76).
50	Remove the lower I/DWR ring (9)
51	Remove and replace the lip seal (30). NOTICE! The gasket cavity is directed towards the valve seat (7).
52	Replace the lower I/DWR ring (9) NOTICE! Before inserting the replacement I/DWR ring, clean the retaining slots with a cleaning solution.
53	Fit the lower circlip (76).
54	Remove the O-rings (85, 88, 89) and replace them, taking care to lubricate them with synthetic grease. NOTICE! Before inserting the replacement O-rings, clean the retaining slots with a cleaning solution.
55	Insert the rod guide sleeve (13) together with the upper I/DWR rings (9), the upper and lower circlips (76), and the lip seal (30) into the flange (37).
56	Insert and fix the nut (66) according to the following tightening torques: • 4": tab. 9.70
57	Undo and remove the screws (60).
58	Remove the shaft collars (14, 15) together with the screws (62), the balancing diaphragm (29), and the spacer (17) from the intermediate body (16).
59	Undo and remove the screws (62) of the spacer (17).
60	Remove the shaft collar (15).
61	Remove the balancing diaphragm (29) and replace it, taking care to lubricate it with synthetic grease. NOTICE! Before inserting the replacement diaphragm, clean the retaining slots with a cleaning solution.
62	Fit the shaft collar (15).
63	Insert and fix the nut (62) according to the following tightening torques: • 4": tab. 9.70
64	Fit the assembly (9, 11, 13, 15, 17, 29, 30, 37, 62, 66, 76, 85, 88, 89) into the intermediate body (16).



NORVAL Regulator 4" (head 495)

Step	Action
65	Insert and fix the screws (60) according to the following tightening torques: <ul style="list-style-type: none"> • 4": tab. 9.70 <div style="border: 1px solid black; padding: 5px;">  NOTICE! </div> <p>Tighten the screws according to the cross diagram in paragraph 9.4.2.2.</p>
66	Fit the flange (37) into the intermediate body (16).
67	Undo and remove the screws (59).
68	Remove the shaft collar (6).
69	Pull out the valve seat (7) from the body (2).
70	Remove the O-rings (87) from the valve seat (7) and replace them, taking care to lubricate them with synthetic grease. <div style="border: 1px solid black; padding: 5px;">  NOTICE! </div> <p>Before inserting the replacement O-rings, clean the retaining slots with a cleaning solution.</p>
71	Fit the valve seat (7) in the body (2).
72	Fit the shaft collar (6).
73	Insert and fix the screws (59) according to the following tightening torques: <ul style="list-style-type: none"> • 4": tab. 9.70 <div style="border: 1px solid black; padding: 5px;">  NOTICE! </div> <p>Tighten the screws according to the cross diagram in paragraph 9.4.2.2.</p>
74	Fit the intermediate body (16) into the body (2).
75	Insert and fix the screws (55) according to the following tightening torques: <ul style="list-style-type: none"> • 4": tab. 9.70 <div style="border: 1px solid black; padding: 5px;">  NOTICE! </div> <p>Tighten the screws according to the cross diagram in paragraph 9.4.2.2.</p>
76	Remove the O-ring (90) and replace it, taking care to lubricate it with synthetic grease. <div style="border: 1px solid black; padding: 5px;">  NOTICE! </div> <p>Before inserting the replacement O-ring, clean the retaining slots with a cleaning solution.</p>
77	Position the spacer (38) together with the O-ring (93).
78	Remove the O-ring (86) and replace it, taking care to lubricate it with synthetic grease. <div style="border: 1px solid black; padding: 5px;">  NOTICE! </div> <p>Before inserting the replacement O-ring, clean the retaining slots with a cleaning solution.</p>
79	Fit the bottom cover (19).
80	Insert and fix the screws (56) according to the following tightening torques: <ul style="list-style-type: none"> • 4": tab. 9.70 <div style="border: 1px solid black; padding: 5px;">  NOTICE! </div> <p>Tighten the screws according to the cross diagram in paragraph 9.4.2.2.</p>

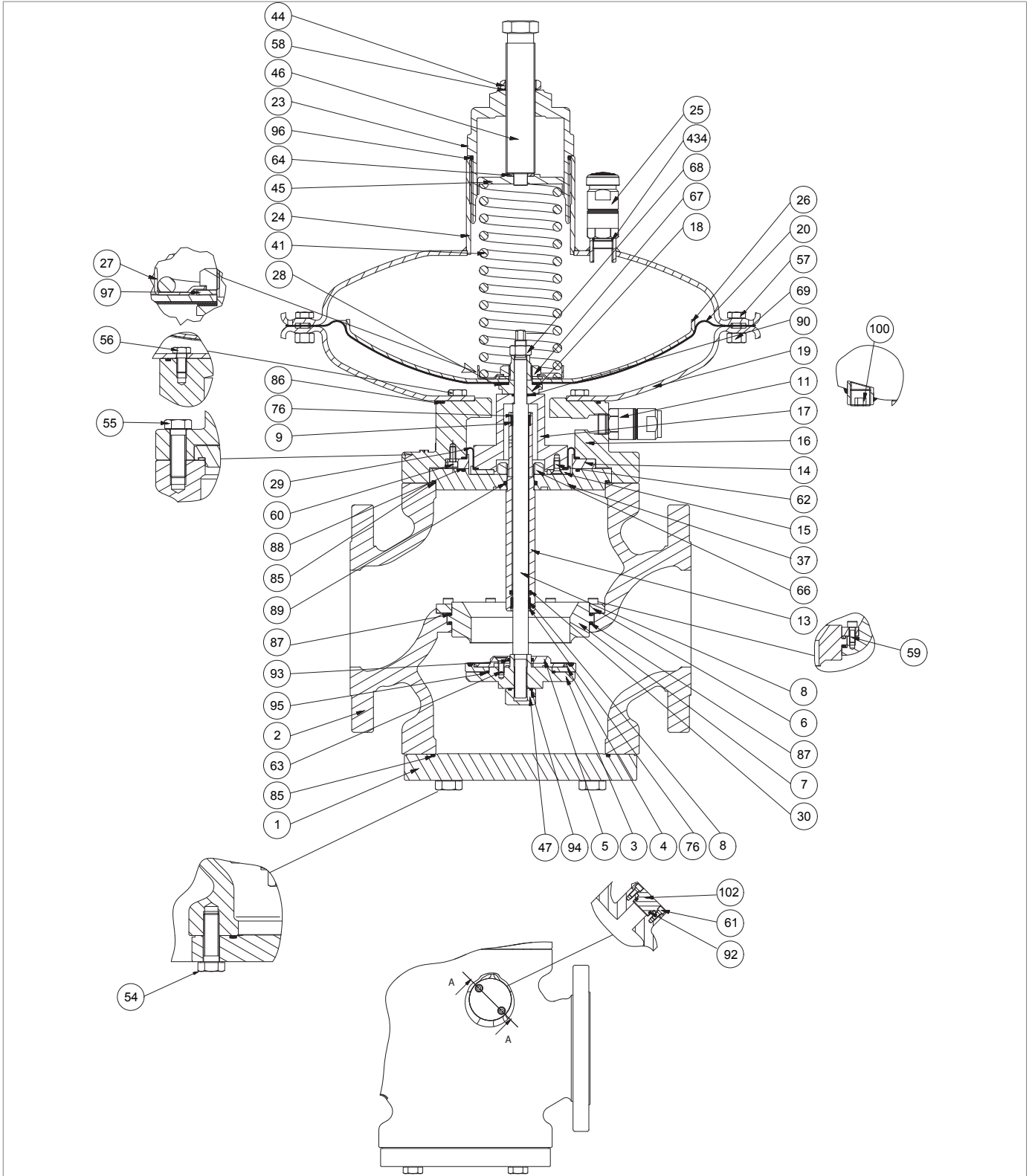

NORVAL Regulator 4" (head 495)

Step	Action
81	Fit the diaphragm assembly (18, 20, 26, 27, 28, 67, 97). NOTICE! Centre the diaphragm support hole (18) with the hole of the spacer (38).
82	Insert the rod (8) into the rod guide sleeve (13) from the bottom upwards.
83	Insert the lock nut (68). NOTICE! Align the housing of the rod fixing spanner (8) and the housing of the diaphragm support fixing spanner (18).
84	Centre the hole of the diaphragm (20) with the bottom cover holes (19).
85	Fix the nut (68) according to the following tightening torques: • 4": tab. 9.70 NOTICE! During this phase, keep the rod (8) and the diaphragm support (18) still.
86	Fit the top cover (24). NOTICE! Align the anti-pumping valve (25) in the direction of the downstream flow.
87	Insert and fix the screws (57) together with the nuts (69) according to the following tightening torques: • 4": tab. 9.70 NOTICE! Tighten the screws according to the cross diagram in paragraph 9.4.2.2.
88	Screw the adjustment assembly (3, 4, 5, 63, 93, 95) into the rod (8) clockwise.
89	Insert and fix the nut (47) according to the following tightening torques: • 4": tab. 9.70
90	Fit the lower flange (1).
91	Insert and fix the screws (54) according to the following tightening torques: • 4": tab. 9.70 NOTICE! Tighten the screws according to the cross diagram in paragraph 9.4.2.2.
94	Insert the regulation spring (41).
95	Insert the spring guide (45) together with the disc (64).
96	Insert and fix the cap (23), together with the O-rings (58, 96), the adjustment screw (46) and the lock nut (44).

Tab. 9.100.

WARNING!
Ensure that all parts have been fitted correctly.

9.4.4.11 - NORVAL REGULATOR 4" (HEAD 630)

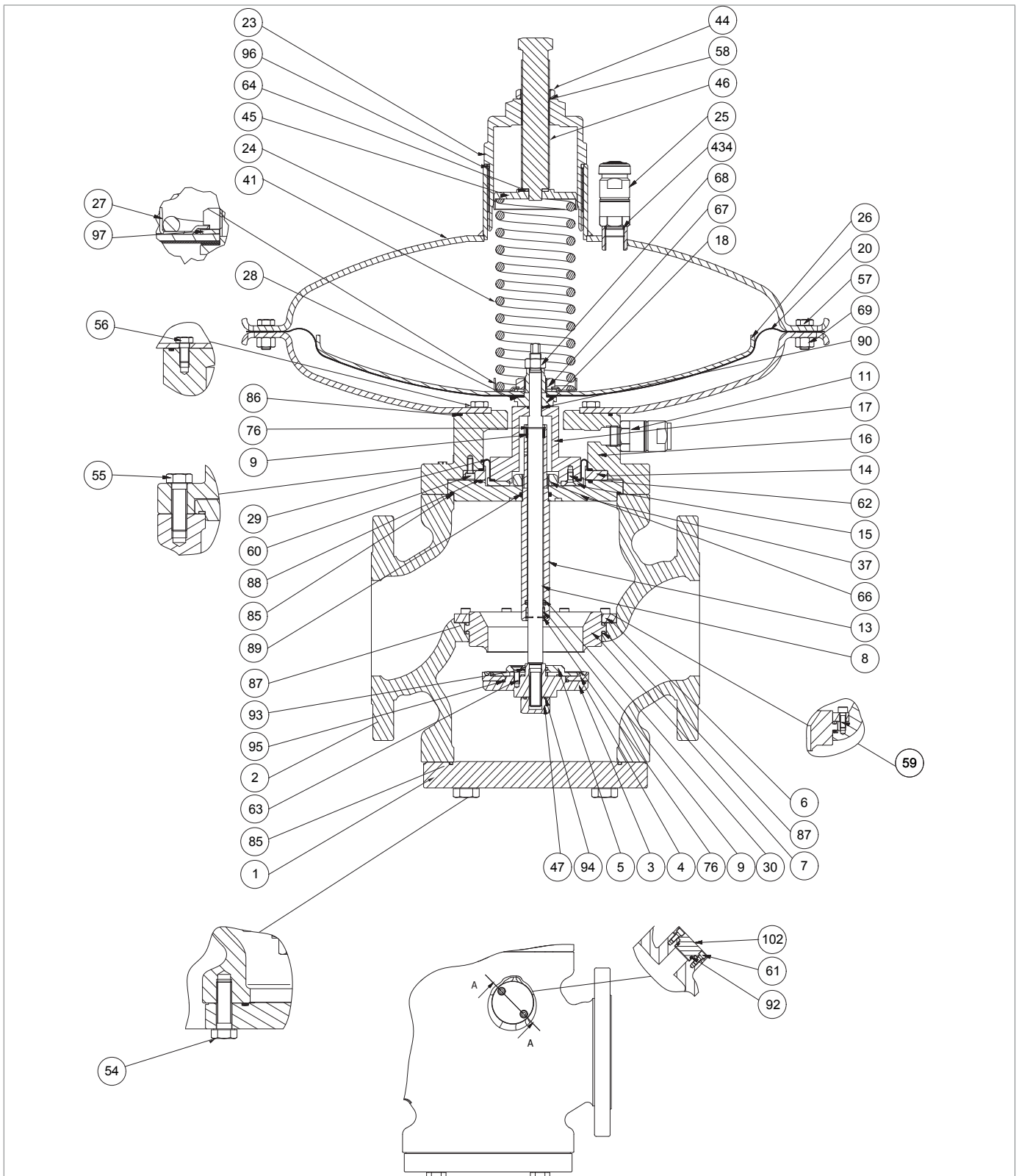





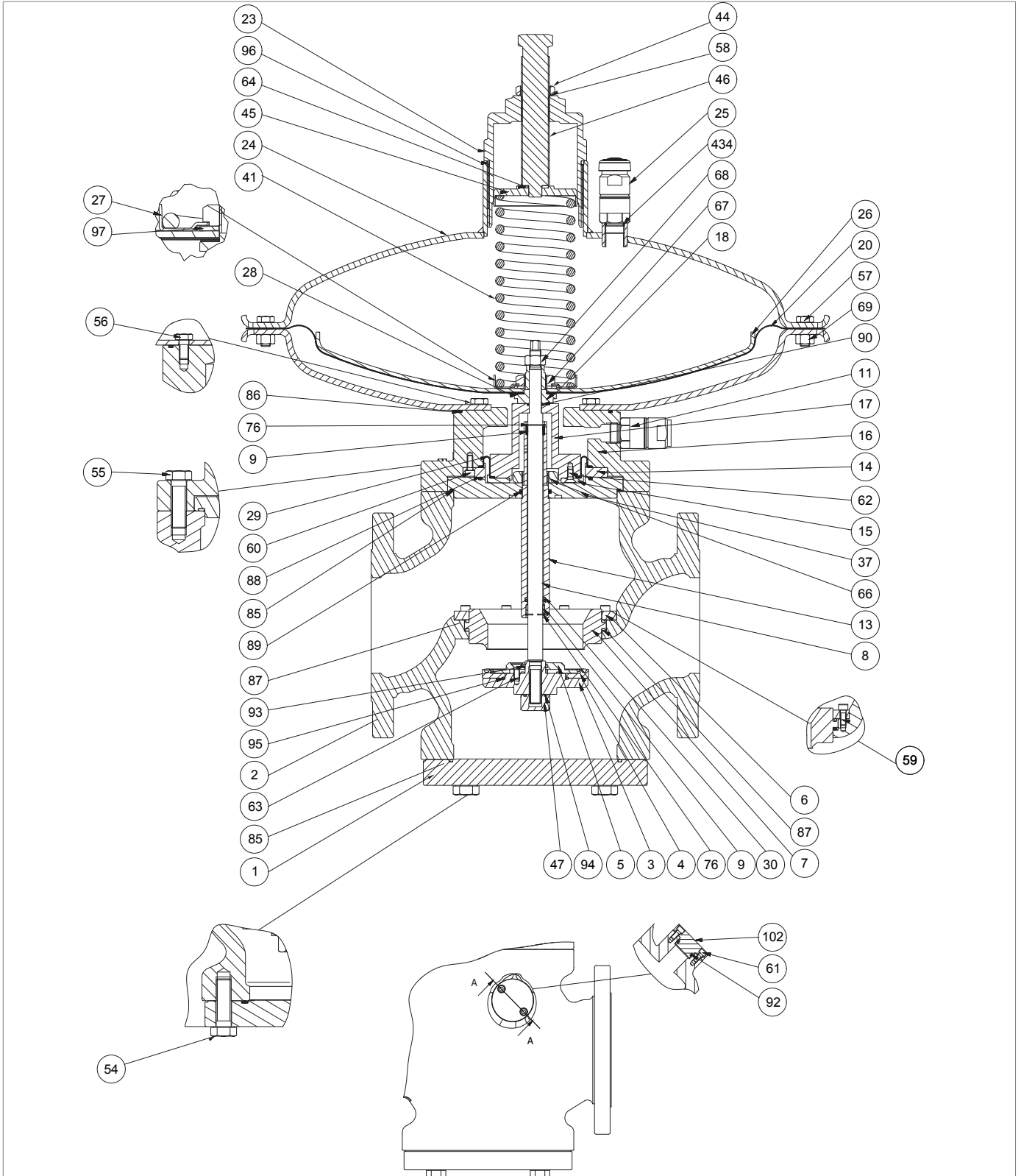

Fig. 9.44. NORVAL Regulator 4" (head 630)

Step	Action
1	Unscrew the lock nut (44).
2	Undo and remove the adjustment screw (46).
3	Remove the O-ring (58) and replace it, taking care to lubricate it with synthetic grease.  NOTICE! Before inserting the replacement O-ring, clean the retaining slots with a cleaning solution.
4	Unscrew and remove the cap (23).
5	Remove the O-ring (96) and replace it, taking care to lubricate it with synthetic grease.  NOTICE! Before inserting the replacement O-ring, clean the retaining slots with a cleaning solution.
6	Remove the spring guide disc (45) together with the disc (64).
7	Remove the setting spring (41).
8	Unscrew and remove the anti-pumping valve (25) from the top cover (24).
9	Remove the O-ring (434) and replace it, taking care to lubricate it with synthetic grease.  NOTICE! Before inserting the replacement O-ring, clean the retaining slots with a cleaning solution.
10	Position and secure the anti-pumping valve (25) in the top cover (24).
11	Undo and remove the screws (54).
12	Remove the lower flange (1).  ATTENTION! In the presence of the ER device, refer to paragraph 9.4.5 for maintenance.
13	Remove the O-ring (85) and replace it, taking care to lubricate it with synthetic grease.  NOTICE! Before inserting the replacement O-ring, clean the retaining slots with a cleaning solution.
14	Unscrew and remove the nut (47).
15	Remove the O-ring (94) and replace it, taking care to lubricate it with synthetic grease.  NOTICE! Before inserting the replacement O-ring, clean the retaining slots with a cleaning solution.
16	Unscrew the adjustment assembly (3, 4, 5, 63, 93, 95) from the rod (8) anti-clockwise.
17	Undo and remove the screws (63).
18	Remove the protection disk (5) from the gasket support (3).
19	Remove the reinforced gasket (4) from the gasket support (3).







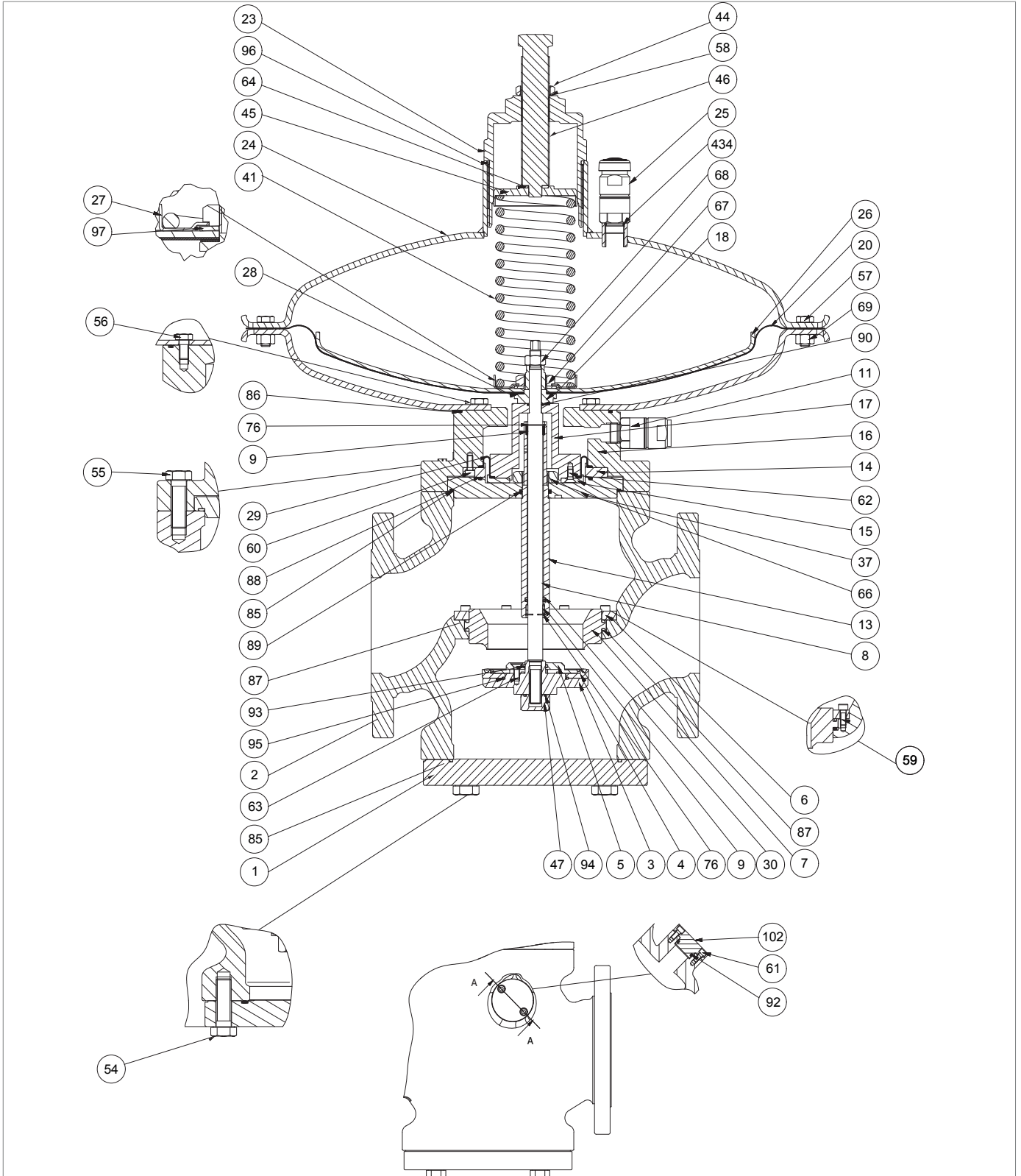

NORVAL Regulator 4" (head 630)

Step	Action
20	Remove the O-rings (93, 95) from the gasket support (3) and replace them, taking care to lubricate them with synthetic grease. NOTICE! Before inserting the replacement O-rings, clean the retaining slots with a cleaning solution.
21	Replace the reinforced gasket (4).
22	Place the protection disc (5) in the gasket support (3).
23	Insert and fix the screws (63) according to the following tightening torques: • 4": tab. 9.87 NOTICE! Tighten the screws according to the cross diagram in paragraph 9.4.2.2.
24	Undo and remove the screws (57) together with the nuts (69).
25	Remove the top cover (24).
26	Unscrew and remove the locking nut (68).
27	Pull out the rod (8) from the top downwards.
28	Remove the diaphragm assembly (18, 20, 26, 27, 28, 67, 97) placing it on a shockproof surface.
29	Unscrew and remove the nut (67). NOTICE! During this phase, keep the diaphragm support (18) still.
30	Remove the spring guide disc (27) together with the circlip (97).
31	Remove the protection discs (26).
32	Remove the diaphragm (20).
33	Remove the oil seal (28) and replace it.
34	Fit the diaphragm (20).
35	Fit the protection discs (26).
36	Fit the spring washer (97).
37	Fit the spring guide disc (27).
38	Insert and fix the nut (67) according to the following tightening torques: • 4": tab. 9.70 NOTICE! During this phase, keep the diaphragm support (18) still.
39	Undo and remove the screws (56).
40	Remove the bottom cover (19) from the intermediate body (16).
41	Undo and remove the screws (55).
42	Remove the intermediate body assembly (9, 11, 13, 15, 17, 29, 30, 37, 62, 66, 76, 85, 88, 89).
43	Pull out the flange (37), together with the rod guide sleeve (13), the nut (66), the O-rings (85, 88, 89), the upper and lower circlips (76), the upper and lower I/DWR rings (9), and the lip seal (30) from the intermediate body (16). ATTENTION! In the presence of the SN slam-shut valve, see paragraph 9.4.6 for maintenance.



NORVAL Regulator 4" (head 630)

Step	Action
44	Unscrew and remove the nut (66) from the rod guide sleeve (13).
45	Pull out the rod guide sleeve (13) from the flange spacer (37).
46	Remove the upper circlip (76)
47	Remove and replace the upper I/DWR ring (9). NOTICE! Before inserting the replacement I/DWR ring, clean the retaining slots with a cleaning solution.
48	Fit the upper circlip (76).
49	Remove the lower circlip (76).
50	Remove the lower I/DWR ring (9)
51	Remove and replace the lip seal (30). NOTICE! The gasket cavity is directed towards the valve seat (7).
52	Replace the lower I/DWR ring (9) NOTICE! Before inserting the replacement I/DWR ring, clean the retaining slots with a cleaning solution.
53	Fit the lower circlip (76).
54	Remove the O-rings (85, 88, 89) and replace them, taking care to lubricate them with synthetic grease. NOTICE! Before inserting the replacement O-rings, clean the retaining slots with a cleaning solution.
55	Insert the rod guide sleeve (13) together with the upper I/DWR rings (9), the upper and lower circlips (76), and the lip seal (30) into the flange (37).
56	Insert and fix the nut (66) according to the following tightening torques: • 4": tab. 9.70
57	Undo and remove the screws (60).
58	Remove the shaft collars (14, 15) together with the screws (62), the balancing diaphragm (29), and the spacer (17) from the intermediate body (16).
59	Undo and remove the screws (62) of the spacer (17).
60	Remove the shaft collar (15).
61	Remove the balancing diaphragm (29) and replace it, taking care to lubricate it with synthetic grease. NOTICE! Before inserting the replacement diaphragm, clean the retaining slots with a cleaning solution.
62	Fit the shaft collar (15).
63	Insert and fix the nut (62) according to the following tightening torques: • 4": tab. 9.70
64	Fit the assembly (9, 11, 13, 15, 17, 29, 30, 37, 62, 66, 76, 85, 88, 89) into the intermediate body (16).

Step	Action
65	<p>Insert and fix the screws (60) according to the following tightening torques:</p> <ul style="list-style-type: none"> • 4": tab. 9.70 <div style="border: 1px solid black; padding: 5px;">  NOTICE! </div> <p>Tighten the screws according to the cross diagram in paragraph 9.4.2.2.</p>
66	Fit the flange (37) into the intermediate body (16).
67	Undo and remove the screws (59).
68	Remove the shaft collar (6).
69	Pull out the valve seat (7) from the body (2).
70	<p>Remove the O-rings (87) from the valve seat (7) and replace them, taking care to lubricate them with synthetic grease.</p> <div style="border: 1px solid black; padding: 5px;">  NOTICE! </div> <p>Before inserting the replacement O-rings, clean the retaining slots with a cleaning solution.</p>
71	Fit the valve seat (7) in the body (2).
72	Fit the shaft collar (6).
73	<p>Insert and fix the screws (59) according to the following tightening torques:</p> <ul style="list-style-type: none"> • 4": tab. 9.70 <div style="border: 1px solid black; padding: 5px;">  NOTICE! </div> <p>Tighten the screws according to the cross diagram in paragraph 9.4.2.2.</p>
74	Fit the intermediate body (16) into the body (2).
75	<p>Insert and fix the screws (55) according to the following tightening torques:</p> <ul style="list-style-type: none"> • 4": tab. 9.70 <div style="border: 1px solid black; padding: 5px;">  NOTICE! </div> <p>Tighten the screws according to the cross diagram in paragraph 9.4.2.2.</p>
76	<p>Remove the O-ring (90) and replace it, taking care to lubricate it with synthetic grease.</p> <div style="border: 1px solid black; padding: 5px;">  NOTICE! </div> <p>Before inserting the replacement O-ring, clean the retaining slots with a cleaning solution.</p>
77	Position the spacer (38) together with the O-ring (93).
78	<p>Remove the O-ring (86) and replace it, taking care to lubricate it with synthetic grease.</p> <div style="border: 1px solid black; padding: 5px;">  NOTICE! </div> <p>Before inserting the replacement O-ring, clean the retaining slots with a cleaning solution.</p>
79	Fit the bottom cover (19).
80	<p>Insert and fix the screws (56) according to the following tightening torques:</p> <ul style="list-style-type: none"> • 4": tab. 9.70 <div style="border: 1px solid black; padding: 5px;">  NOTICE! </div> <p>Tighten the screws according to the cross diagram in paragraph 9.4.2.2.</p>

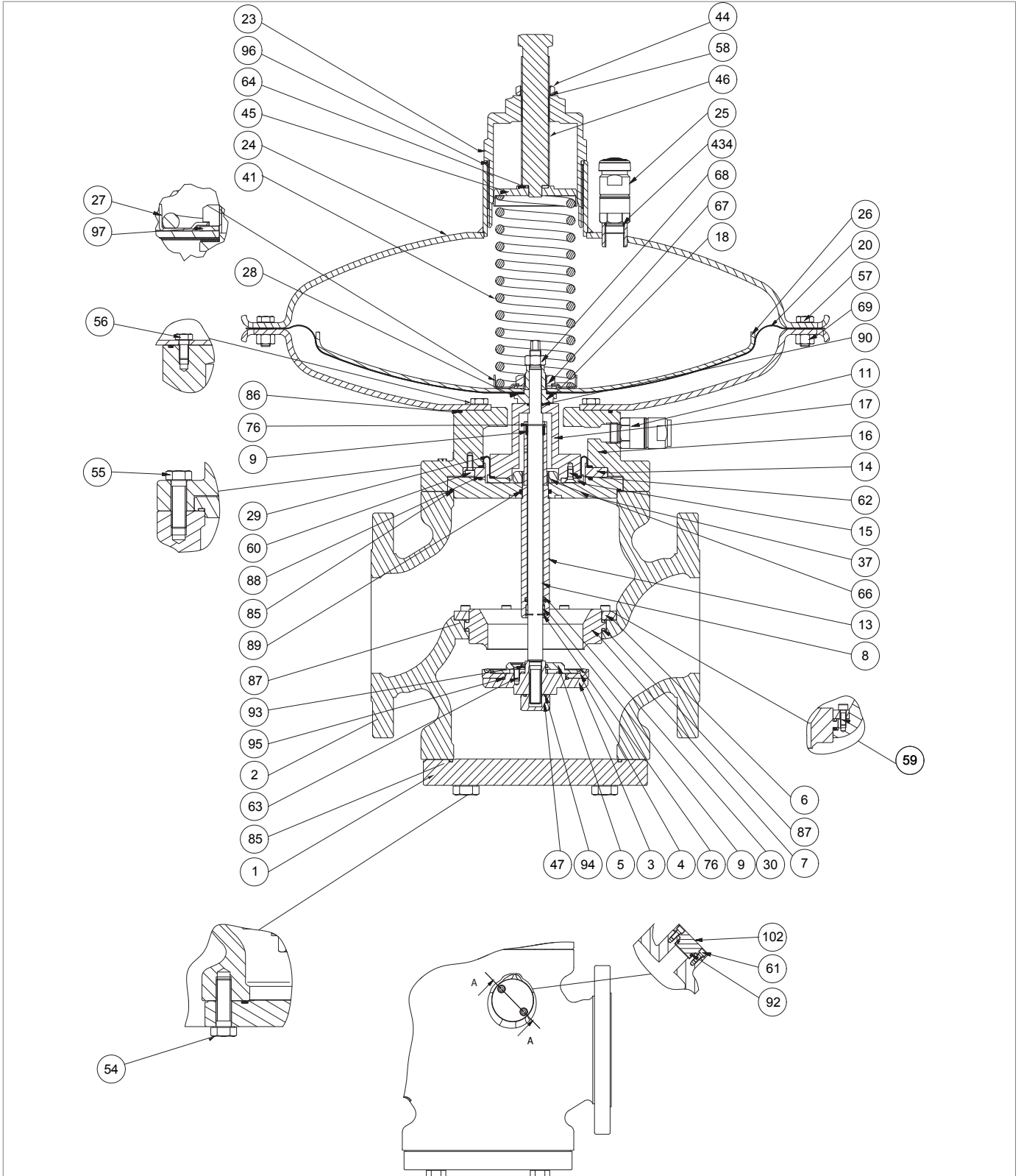

NORVAL Regulator 4" (head 630)

Step	Action
81	Fit the diaphragm assembly (18, 20, 26, 27, 28, 67, 97). NOTICE! Centre the diaphragm support hole (18) with the hole of the spacer (38).
82	Insert the rod (8) into the rod guide sleeve (13) from the bottom upwards.
83	Insert the lock nut (68). NOTICE! Align the housing of the rod fixing spanner (8) and the housing of the diaphragm support fixing spanner (18).
84	Centre the hole of the diaphragm (20) with the bottom cover holes (19).
85	Fix the nut (68) according to the following tightening torques: • 4": tab. 9.70 NOTICE! During this phase, keep the rod (8) and the diaphragm support (18) still.
86	Fit the top cover (24). NOTICE! Align the anti-pumping valve (25) in the direction of the downstream flow.
87	Insert and fix the screws (57) together with the nuts (69) according to the following tightening torques: • 4": tab. 9.70 NOTICE! Tighten the screws according to the cross diagram in paragraph 9.4.2.2.
88	Screw the adjustment assembly (3, 4, 5, 63, 93, 95) into the rod (8) clockwise.
89	Insert and fix the nut (47) according to the following tightening torques: • 4": tab. 9.70
90	Fit the lower flange (1).
91	Insert and fix the screws (54) according to the following tightening torques: • 4": tab. 9.70 NOTICE! Tighten the screws according to the cross diagram in paragraph 9.4.2.2.
94	Insert the regulation spring (41).
95	Insert the spring guide (45) together with the disc (64).
96	Insert and fix the cap (23), together with the O-rings (58, 96), the adjustment screw (46) and the lock nut (44).

Tab. 9.101.

WARNING!

Ensure that all parts have been fitted correctly.

9.4.4.12 - NORVAL REGULATOR 6" - 8" (HEAD 495)

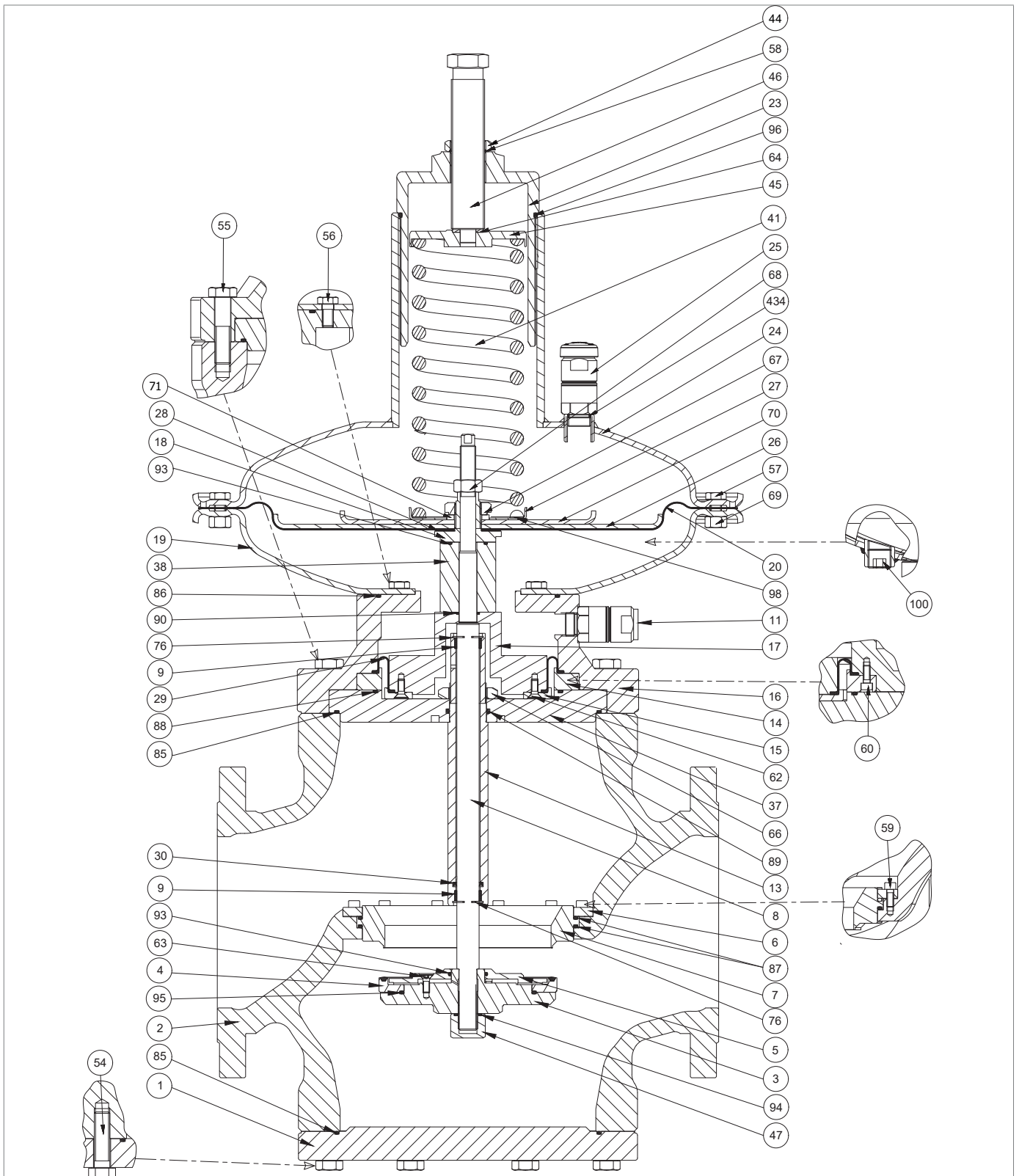







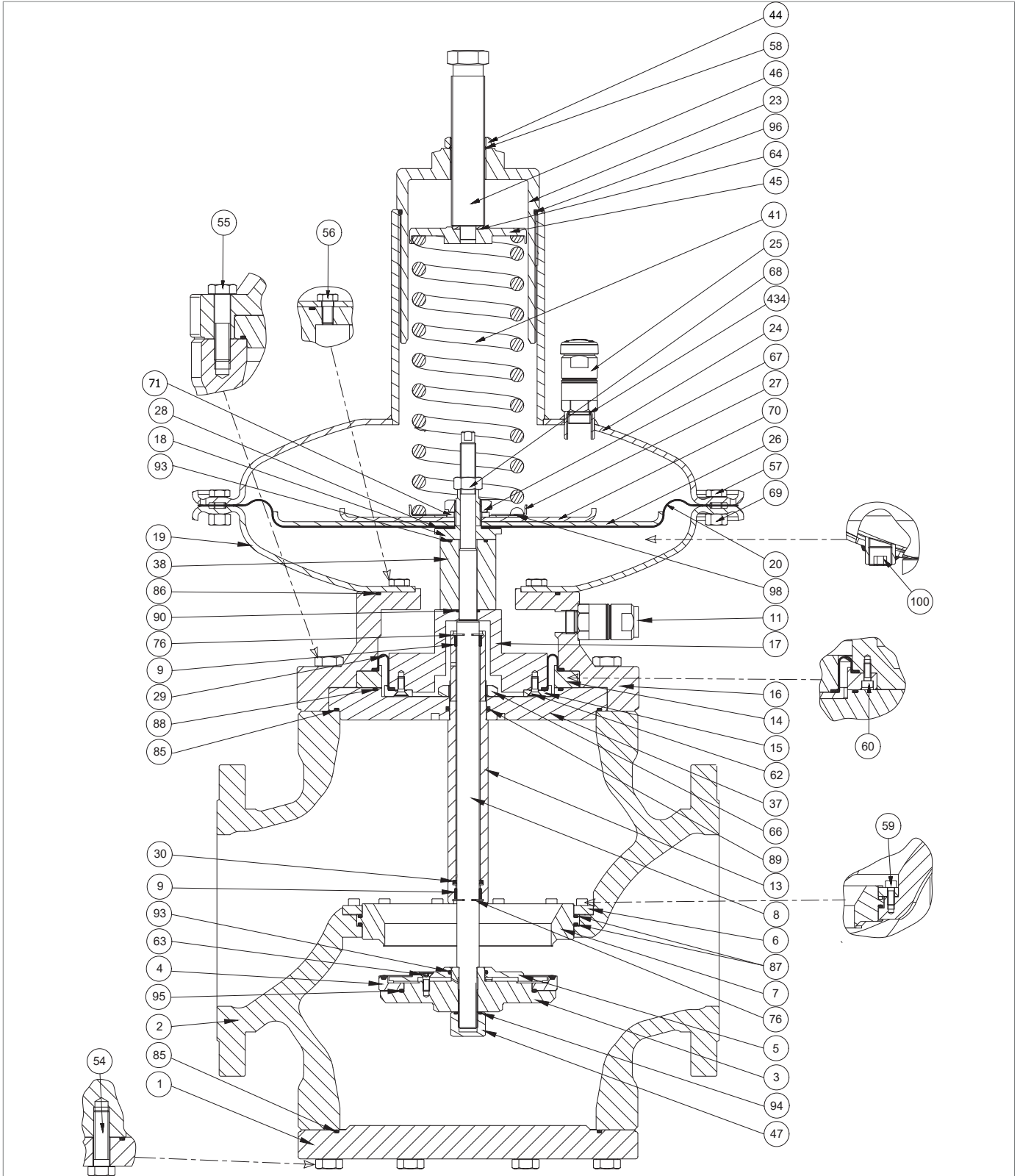





Fig. 9.45. NORVAL Regulator 6" - 8" (head 495)

Step	Action
1	 ATTENTION! In the presence of the ER device, after step 11 and 92, refer to paragraph 9.4.5 for maintenance.
2	Unscrew the lock nut (44).
3	Undo and remove the adjustment screw (46).
4	Remove the O-ring (58) from the lock nut (44) and replace it, taking care to lubricate it with synthetic grease.  NOTICE! Before inserting the replacement O-ring, clean the retaining slots with a cleaning solution.
5	Unscrew and remove the cap (23).
6	Remove the O-ring (96) from the cap (23) and replace it, taking care to lubricate it with synthetic grease.  NOTICE! Before inserting the replacement O-ring, clean the retaining slots with a cleaning solution.
7	Remove the spring guide disc (45) together with the disc (64).
8	Remove the setting spring (41).
9	Unscrew and remove the anti-pumping valve (25) from the top cover (24).
10	Remove the O-ring (434) and replace it, taking care to lubricate it with synthetic grease.  NOTICE! Before inserting the replacement O-ring, clean the retaining slots with a cleaning solution.
11	Position and secure the anti-pumping valve (25) in the top cover (24).
12	Undo and remove the screws (54).
13	Remove the bottom flange (1), taking care to support it.
14	Remove the O-ring (85) and replace it, taking care to lubricate it with synthetic grease.  NOTICE! Before inserting the replacement O-ring, clean the retaining slots with a cleaning solution.
15	Unscrew and remove the nut (47).
16	Remove the O-ring (94) and replace it, taking care to lubricate it with synthetic grease.  NOTICE! Before inserting the replacement O-ring, clean the retaining slots with a cleaning solution.
17	Unscrew the adjustment assembly (3, 4, 5, 63, 93, 95) from the rod (8) anti-clockwise.
18	Undo and remove the screws (63).
19	Remove the protection disk (5) from the gasket support (3).
20	Remove the reinforced gasket (4) from the gasket support (3) and replace it.
21	Remove the O-rings (93, 95) from the gasket support (3) and replace them, taking care to lubricate them with synthetic grease.  NOTICE! Before inserting the replacement O-rings, clean the retaining slots with a cleaning solution.



NORVAL Regulator 6'' - 8'' (head 495)

Step	Action
22	Fit the reinforced gasket (4).
23	Place the protection disc (5) in the gasket support (3).
24	Undo and remove the screws (57) together with the nuts (69).
25	Remove the top cover (24).
26	Unscrew and remove the locking nut (68).  NOTICE! During this phase, keep the rod (8) still.
27	Pull out the rod (8) from the top downwards.
28	Remove the diaphragm assembly (18, 20, 26, 27, 28, 67, 70, 98) placing it on a shockproof surface.
29	Unscrew and remove the nut (67).  NOTICE! During this phase, keep the diaphragm support (18) still.
31	Remove the washer disc (98).
32	Remove the spring guide disc (27).
33	Remove the protection discs (26, 70).
34	Remove and replace the diaphragm (20).
35	Remove the oil seal (28) and replace it.
36	Fit the oil seal (28).
37	Fit the diaphragm (20).
38	Fit the protection discs (26, 70).
39	Fit the spring guide disc (27).
40	Insert and fix the nut (67) according to the following tightening torques: <ul style="list-style-type: none"> • 6": tab. 9.71 • 8": tab. 9.72  NOTICE! During this phase, keep the diaphragm support (18) still.
41	Place the washer disc (98) in the spring guide disc (27).
42	Remove the spacer (38) from the rod (8).
43	Remove the O-ring (93) from the spacer (38) and replace it, taking care to lubricate it with synthetic grease.  NOTICE! Before inserting the replacement O-ring, clean the retaining slots with a cleaning solution.
44	Undo and remove the screws (56).
45	Remove the bottom cover (19) from the intermediate body (16).
46	Undo and remove the screws (55)
47	Remove the intermediate body (16).
48	Pull out the flange assembly (9, 13, 17, 30, 37, 66, 76, 88, 89) from the intermediate body (16), placing it on a shockproof surface.

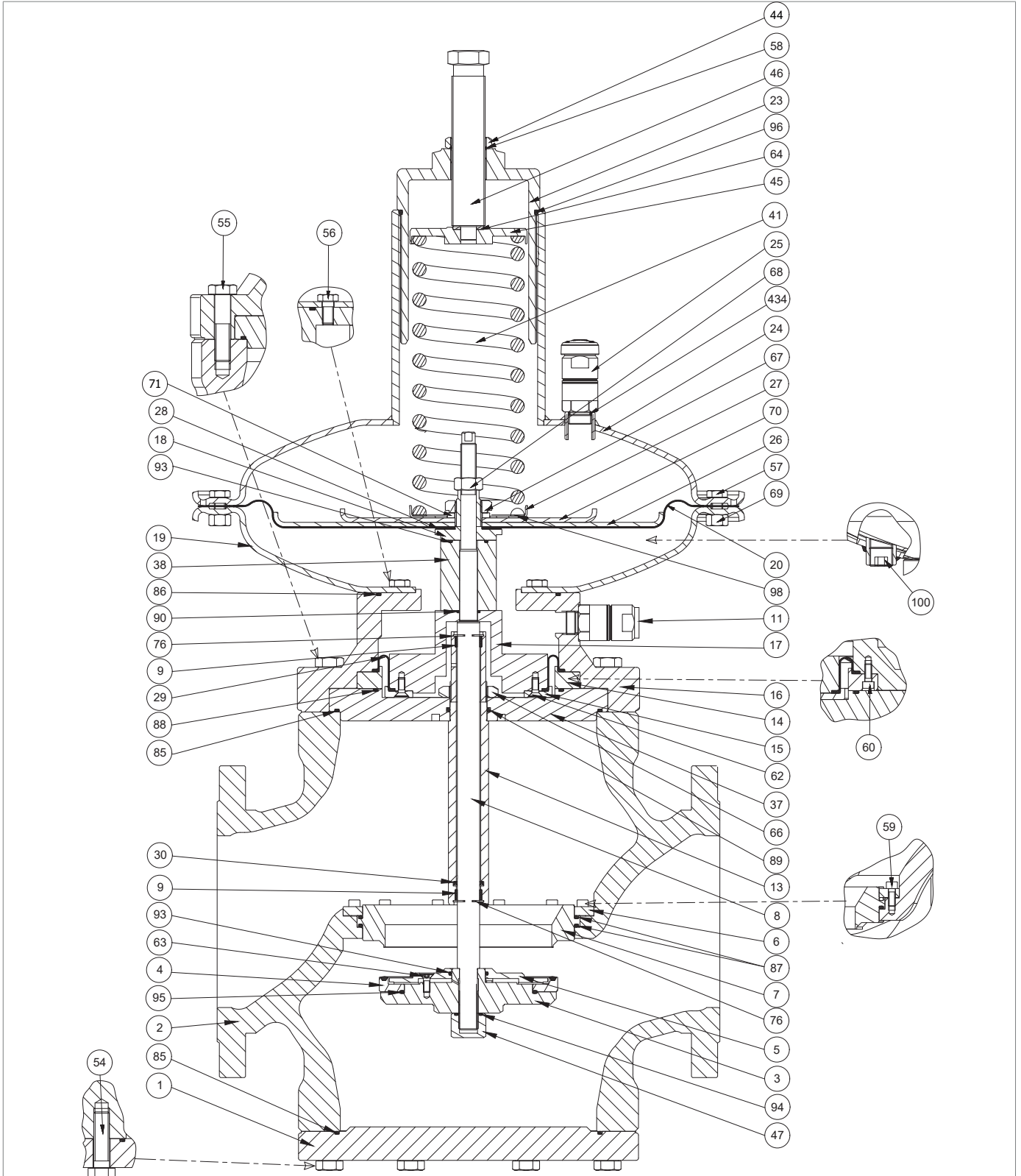





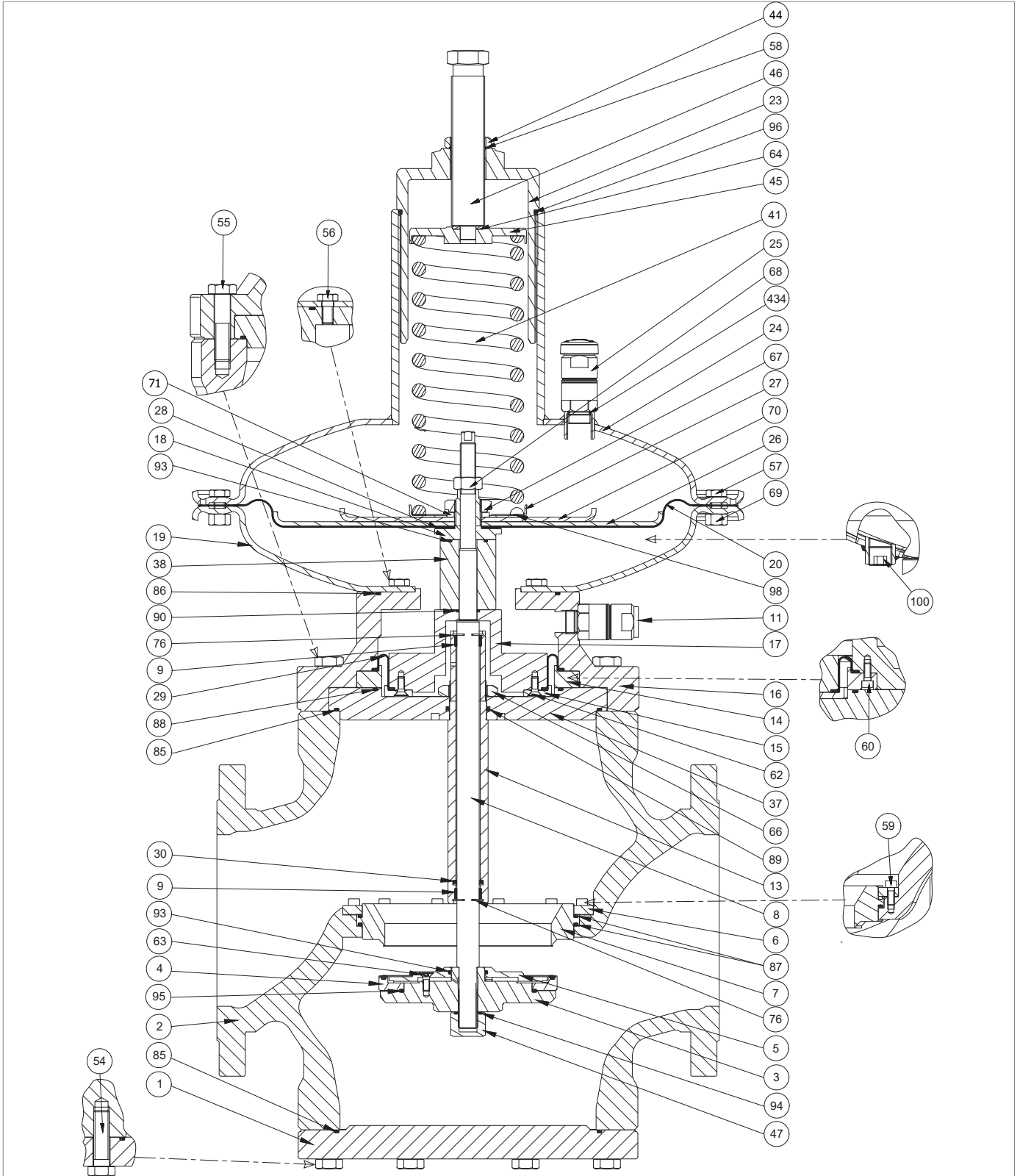

NORVAL Regulator 6" - 8" (head 495)

Step	Action
49	Unscrew and remove the nut (66) from the rod guide sleeve (13).
50	<p>Pull out the rod guide sleeve (13) from the flange (37).</p> <p>⚠ ATTENTION! In the presence of the SN slam-shut valve, see paragraph 9.4.6 for maintenance.</p>
51	Remove the upper circlip (76).
52	<p>Remove and replace the upper I/DWR ring (9).</p> <p>! NOTICE! Before inserting the replacement I/DWR ring, clean the retaining slots with a cleaning solution.</p>
53	Fit the upper circlip (76).
54	Remove the lower circlip (76).
55	Remove the lower I/DWR ring (9).
56	Remove and replace the lip seal (30).
57	Position the lip seal (30).
58	<p>Replace the lower I/DWR ring (9).</p> <p>! NOTICE! Before inserting the replacement I/DWR ring, clean the retaining slots with a cleaning solution.</p>
59	Fit the lower circlip (76).
60	<p>Remove the O-rings (85, 88, 89) from the flange (37) and replace them, taking care to lubricate them with synthetic grease.</p> <p>! NOTICE! Before inserting the replacement O-rings, clean the retaining slots with a cleaning solution.</p>
61	Insert the rod guide sleeve (13) together with the I/DWR rings (9), circlips (76), lip seal (30) into the flange (37).
62	<p>Insert and fix the nut (66) according to the following tightening torque:</p> <ul style="list-style-type: none"> 6": tab. 9.71 8": tab. 9.72
63	Undo and remove the screws (60).
64	Remove the flange (14) together with the screws (62), shaft collar (15), balancing diaphragm (29), and spacer (17) from the intermediate body (16).
65	Undo and remove the screws (62) of the spacer (17).
66	Remove the shaft collar (15).
67	<p>Remove the balancing diaphragm (29) and replace it, taking care to lubricate it with synthetic grease.</p> <p>! NOTICE! Before inserting the replacement diaphragm, clean the retaining slots with a cleaning solution.</p>
68	Fit the shaft collar (15).





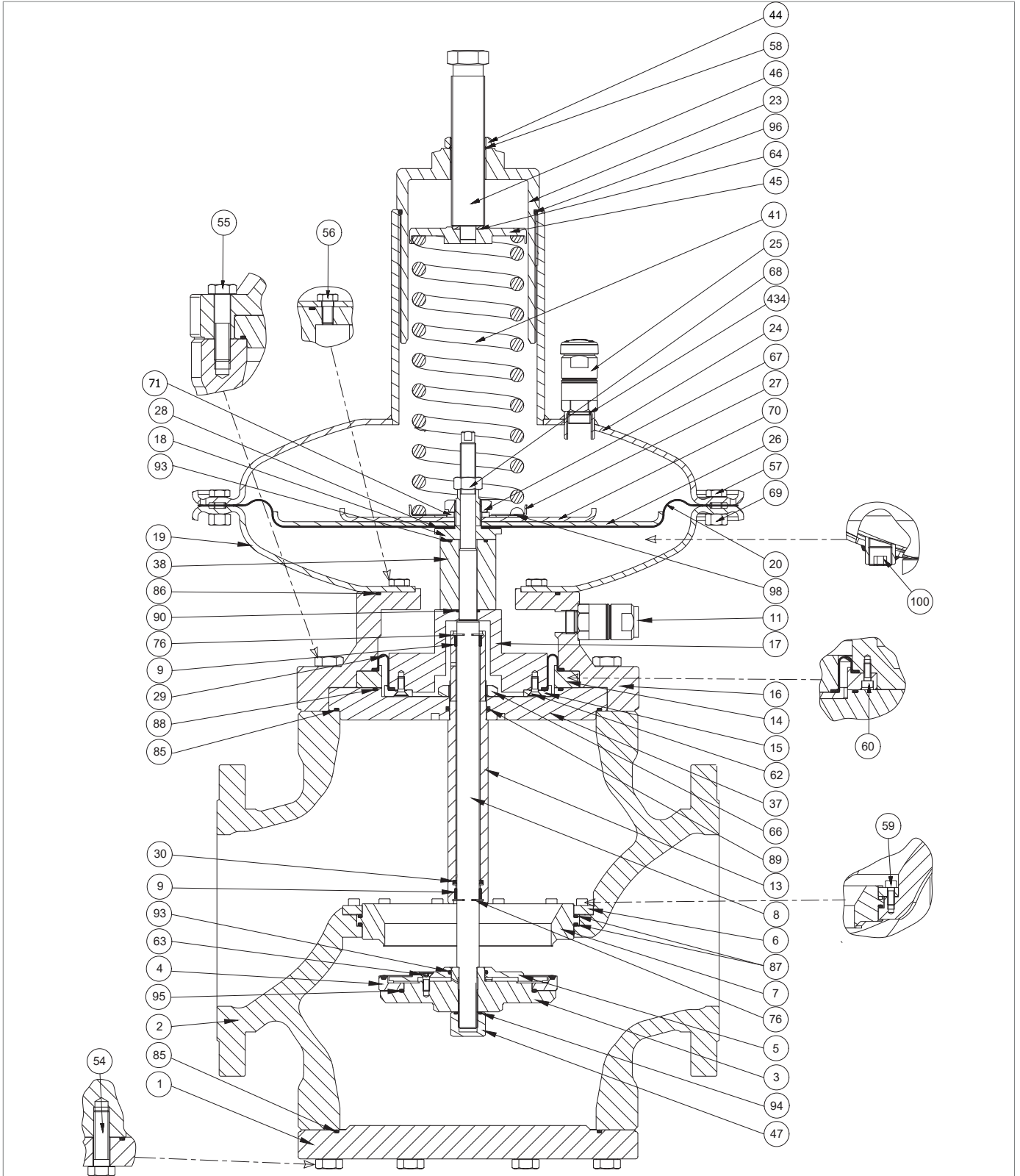

NORVAL Regulator 6" - 8" (head 495)

Step	Action
69	<p>Insert and fix the screws (62) according to the following tightening torque:</p> <ul style="list-style-type: none"> • 6": tab. 9.71 • 8": tab. 9.72 <div style="border: 1px solid black; padding: 5px;">  NOTICE! </div> <p>Tighten the screws according to the cross diagram in paragraph 9.4.2.2.</p>
70	Fit the flange assembly (9, 13, 16, 30, 37, 66, 76, 88, 89) into the intermediate body (16).
71	<p>Insert and fix the screws (60) according to the following tightening torque:</p> <ul style="list-style-type: none"> • 6": tab. 9.71 • 8": tab. 9.72 <div style="border: 1px solid black; padding: 5px;">  NOTICE! </div> <p>Tighten the screws according to the cross diagram in paragraph 9.4.2.2.</p>
72	Undo and remove the screws (59).
73	Remove the shaft collar (6).
74	Pull out the valve seat (7) from the body (2).
75	<p>Remove the O-rings (87) from the valve seat (7) and replace them, taking care to lubricate them with synthetic grease.</p> <div style="border: 1px solid black; padding: 5px;">  NOTICE! </div> <p>Before inserting the replacement O-rings, clean the retaining slots with a cleaning solution.</p>
76	Fit the valve seat (7) in the body (2).
77	Fit the shaft collar (6).
78	<p>Insert and fix the screws (59) according to the following tightening torque:</p> <ul style="list-style-type: none"> • 6": tab. 9.71 • 8": tab. 9.72 <div style="border: 1px solid black; padding: 5px;">  NOTICE! </div> <p>Tighten the screws according to the cross diagram in paragraph 9.4.2.2.</p>
79	Fit the intermediate body (16) into the body (2).
80	<p>Insert and fix the screws (55) according to the following tightening torque:</p> <ul style="list-style-type: none"> • 6": tab. 9.71 • 8": tab. 9.72 <div style="border: 1px solid black; padding: 5px;">  NOTICE! </div> <p>Tighten the screws according to the cross diagram in paragraph 9.4.2.2.</p>
81	<p>Remove the O-ring (90) and replace it, taking care to lubricate it with synthetic grease.</p> <div style="border: 1px solid black; padding: 5px;">  NOTICE! </div> <p>Before inserting the replacement O-ring, clean the retaining slots with a cleaning solution.</p>
82	Position the spacer (38) together with the O-ring (93).
83	<p>Remove the O-ring (86) and replace it, taking care to lubricate it with synthetic grease.</p> <div style="border: 1px solid black; padding: 5px;">  NOTICE! </div> <p>Before inserting the replacement O-ring, clean the retaining slots with a cleaning solution.</p>
84	Fit the bottom cover (19).



NORVAL Regulator 6" - 8" (head 495)

Step	Action
85	Insert and fix the screws (56) according to the following tightening torque: <ul style="list-style-type: none"> • 6": tab. 9.88 • 8": tab. 9.89 <div style="border: 1px solid black; padding: 5px;">  NOTICE! Tighten the screws according to the cross diagram in paragraph 9.4.2.2. </div>
86	Fit the diaphragm assembly (18, 20, 26, 27, 28, 67, 70, 98).
87	Insert the rod (8) into the rod guide sleeve (13) from the bottom upwards.
88	Insert the lock nut (68).
89	Align the hole of the diaphragm (20) with the bottom cover holes (19)
90	Fix the nut (68) according to the following tightening torque: <ul style="list-style-type: none"> • 6": tab. 9.71 • 8": tab. 9.72 <div style="border: 1px solid black; padding: 5px;">  NOTICE! During this phase, keep the rod (8) and the diaphragm support (18) still. </div>
91	Fit the top cover (24).
92	Insert and fix the screws (57) together with the nuts (69) according to the following tightening torque: <ul style="list-style-type: none"> • 6": tab. 9.71 • 8": tab. 9.72 <div style="border: 1px solid black; padding: 5px;">  NOTICE! Tighten the screws according to the cross diagram in paragraph 9.4.2.2. </div>
93	Screw the adjustment assembly (3, 4, 95, 63, 93, 5) into the rod (8) clockwise.
94	Insert and fix the nut (47) together with the O-ring (94) according to the following tightening torque: <ul style="list-style-type: none"> • 6": tab. 9.71 • 8": tab. 9.72
95	Fit the lower flange (1) together with the O-ring (85).
96	Insert and fix the screws (54) according to the following tightening torque: <ul style="list-style-type: none"> • 6": tab. 9.71 • 8": tab. 9.72 <div style="border: 1px solid black; padding: 5px;">  NOTICE! Tighten the screws according to the cross diagram in paragraph 9.4.2.2. </div>
97	Insert the regulation spring (41).
98	Insert the spring guide (45) together with the disc (64).
99	Insert and fix the cap (23), together with the O-rings (58, 96), the adjustment screw (46) and the lock nut (44).

Tab. 9.102.

 **WARNING!**

Ensure that all parts have been fitted correctly.

9.4.4.13 - NORVAL REGULATOR 6" - 8" (HEAD 630)

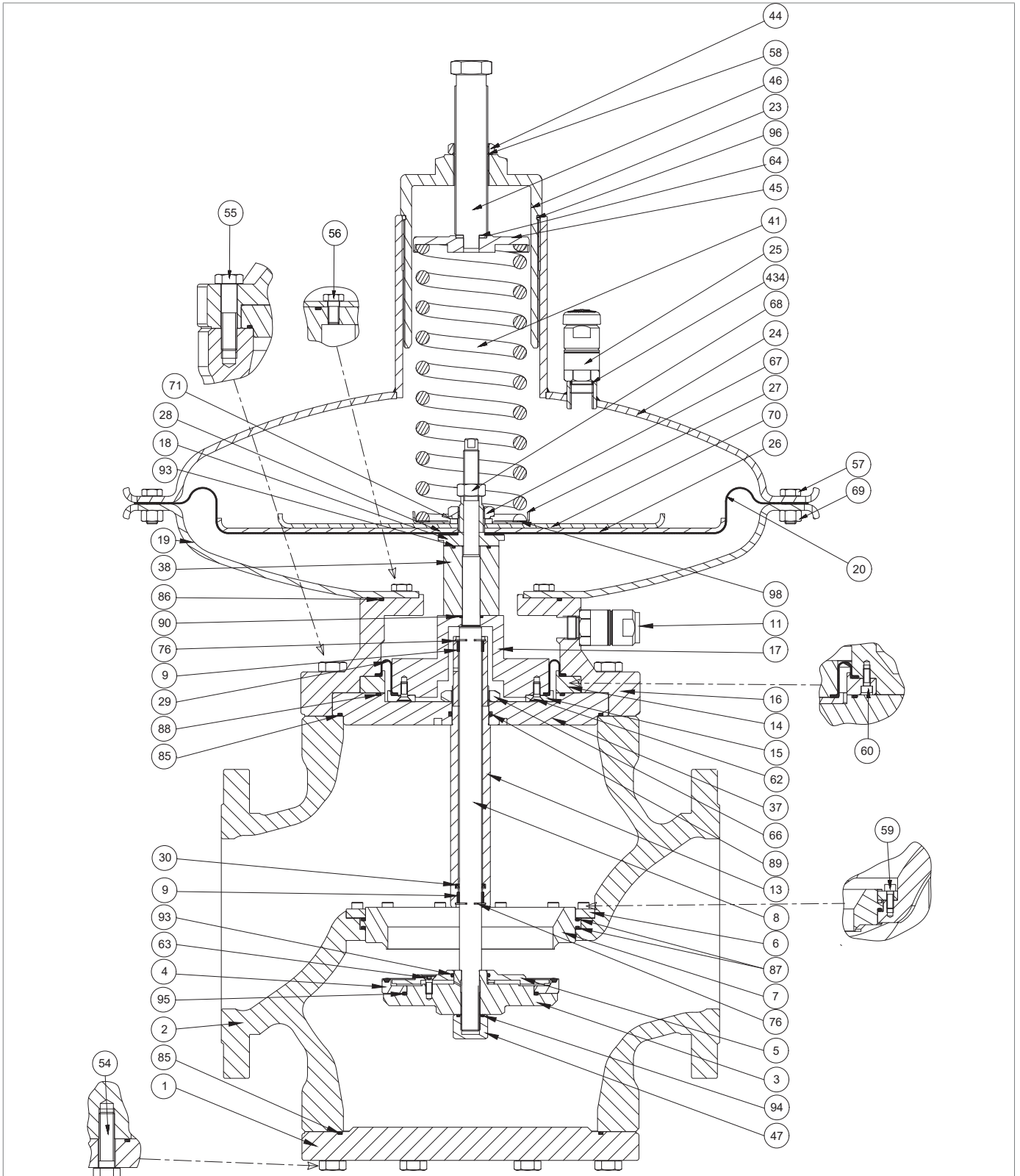





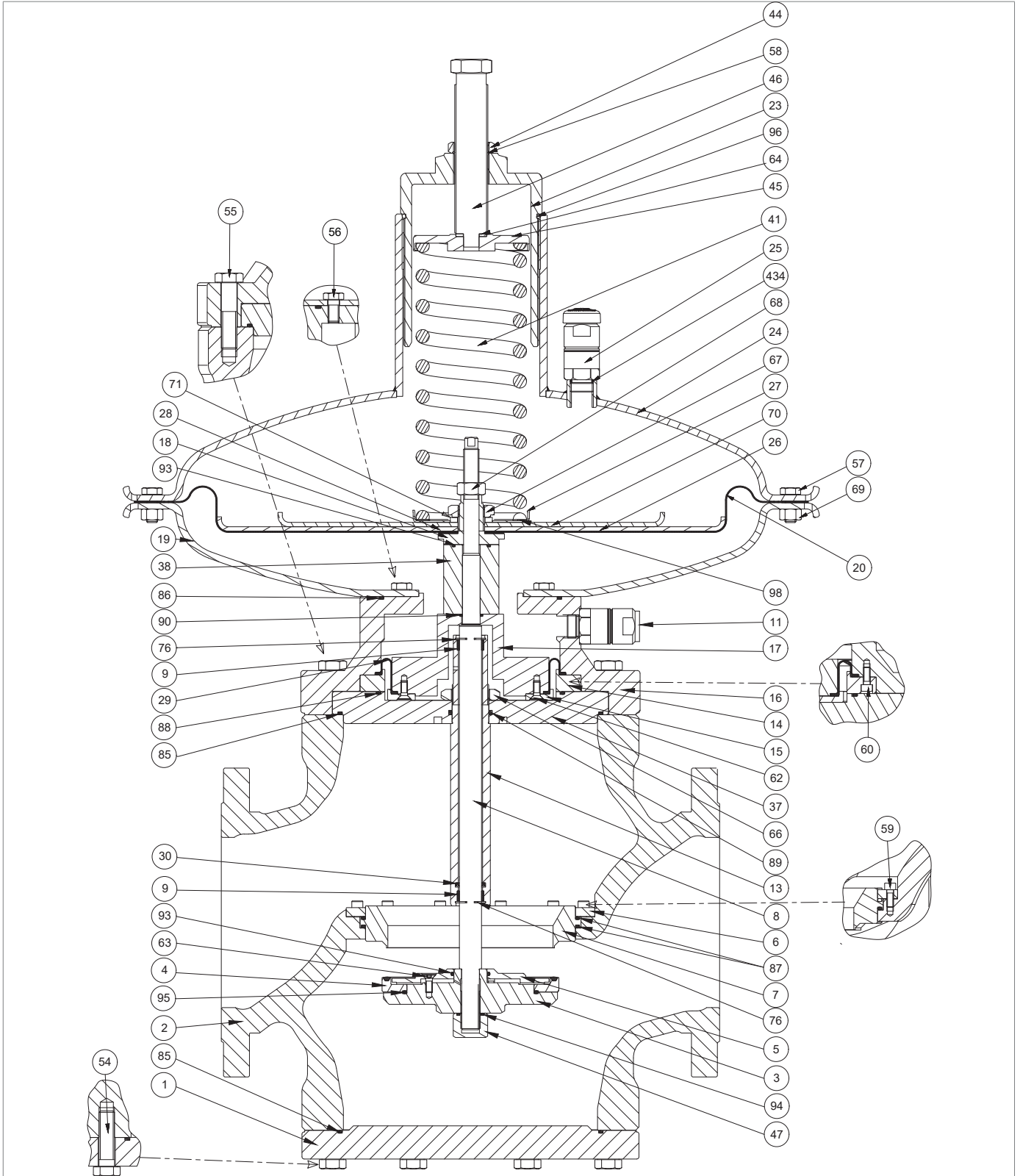





Fig. 9.46. NORVAL Regulator 6" - 8" (head 630)

Step	Action
1	 ATTENTION! In the presence of the ER device, after step 11 and 92, refer to paragraph 9.4.5 for maintenance.
2	Unscrew the lock nut (44).
3	Undo and remove the adjustment screw (46).
4	Remove the O-ring (58) from the lock nut (44) and replace it, taking care to lubricate it with synthetic grease.  NOTICE! Before inserting the replacement O-ring, clean the retaining slots with a cleaning solution.
5	Unscrew and remove the cap (23).
6	Remove the O-ring (96) from the cap (23) and replace it, taking care to lubricate it with synthetic grease.  NOTICE! Before inserting the replacement O-ring, clean the retaining slots with a cleaning solution.
7	Remove the spring guide (45) together with the disc (64).
8	Remove the setting spring (41).
9	Unscrew and remove the anti-pumping valve (25) from the top cover (24).
10	Remove the O-ring (434) and replace it, taking care to lubricate it with synthetic grease.  NOTICE! Before inserting the replacement O-ring, clean the retaining slots with a cleaning solution.
11	Position and secure the anti-pumping valve (25) in the top cover (24).
12	Undo and remove the screws (54).
13	Remove the bottom flange (1), taking care to support it.
14	Remove the O-ring (85) and replace it, taking care to lubricate it with synthetic grease.  NOTICE! Before inserting the replacement O-ring, clean the retaining slots with a cleaning solution.
15	Unscrew and remove the nut (47).
16	Remove the O-ring (94) and replace it, taking care to lubricate it with synthetic grease.  NOTICE! Before inserting the replacement O-ring, clean the retaining slots with a cleaning solution.
17	Unscrew the adjustment assembly (3, 4, 5, 63, 93, 95) from the rod (8) anti-clockwise.
18	Undo and remove the screws (63).
19	Remove the protection disk (5) from the gasket support (3).
20	Remove the reinforced gasket (4) from the gasket support (3) and replace it.
21	Remove the O-rings (93, 95) from the gasket support (3) and replace them, taking care to lubricate them with synthetic grease.  NOTICE! Before inserting the replacement O-rings, clean the retaining slots with a cleaning solution.



NORVAL Regulator 6'' - 8'' (head 630)

Step	Action
21	Fit the reinforced gasket (4).
22	Place the protection disc (5) in the gasket support (3).
23	Undo and remove the screws (57) together with the nuts (69).
24	Remove the top cover (24).
25	Unscrew and remove the locking nut (68). <div style="border: 1px solid black; padding: 5px;">  NOTICE! During this phase, keep the rod (8) still. </div>
26	Pull out the rod (8) from the top downwards.
27	Remove the diaphragm assembly (18, 20, 26, 27, 28, 67, 70, 98).
28	Unscrew and remove the nut (67). <div style="border: 1px solid black; padding: 5px;">  NOTICE! During this phase, keep the diaphragm support (18) still. </div>
29	Remove the washer disc (98).
30	Remove the spring guide disc (27).
31	Remove the protection discs (26, 70).
32	Remove and replace the diaphragm (20).
33	Remove the oil seal (28) and replace it.
34	Fit the oil seal (28).
35	Fit the diaphragm (20).
36	Fit the protection discs (26, 70).
37	Fit the spring guide disc (27).
38	Insert and fix the nut (67) according to the following tightening torques: <ul style="list-style-type: none"> • 6": tab. 9.71 • 8": tab. 9.72 <div style="border: 1px solid black; padding: 5px;">  NOTICE! During this phase, keep the diaphragm support (18) still. </div>
39	Place the washer disc (98) in the spring guide disc (27).
40	Remove the spacer (38) from the rod (8).
41	Remove the O-ring (93) from the spacer (38) and replace it, taking care to lubricate it with synthetic grease. <div style="border: 1px solid black; padding: 5px;">  NOTICE! Before inserting the replacement O-ring, clean the retaining slots with a cleaning solution. </div>
42	Undo and remove the screws (56).
43	Remove the bottom cover (19) from the intermediate body (16).
44	Undo and remove the screws (55)
45	Remove the intermediate body (16).
46	Pull out the flange assembly (9, 13, 17, 30, 37, 66, 76, 88, 89) from the intermediate body (16).
47	Unscrew and remove the nut (66) from the rod guide sleeve (13).

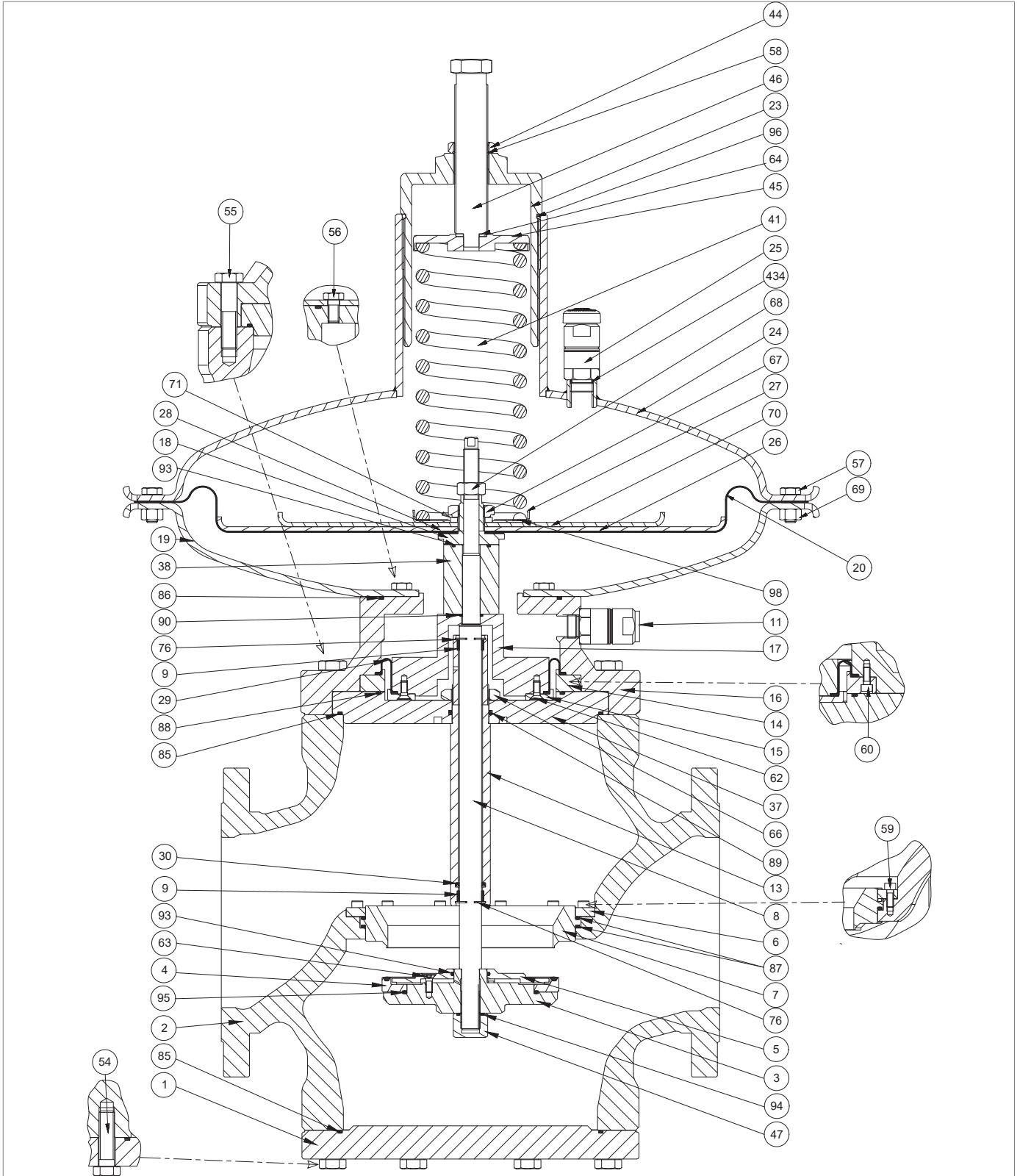

NORVAL Regulator 6'' - 8'' (head 630)

Step	Action
48	<p>Pull out the rod guide sleeve (13) from the flange (37).</p> <p>! ATTENTION! In the presence of the SN slam-shut valve, see paragraph 9.4.6 for maintenance.</p>
49	Remove the upper circlip (76).
50	<p>Remove and replace the upper I/DWR ring (9).</p> <p>! NOTICE! Before inserting the replacement I/DWR ring, clean the retaining slots with a cleaning solution.</p>
51	Fit the upper circlip (76).
52	Remove the lower circlip (76).
53	Remove the lower I/DWR ring (9).
54	Remove and replace the lip seal (30).
55	Position the lip seal (30).
56	<p>Replace the lower I/DWR ring (9).</p> <p>! NOTICE! Before inserting the replacement I/DWR ring, clean the retaining slots with a cleaning solution.</p>
57	Fit the lower circlip (76).
58	<p>Remove the O-rings (85, 88, 89) from the flange (37) and replace them, taking care to lubricate them with synthetic grease.</p> <p>! NOTICE! Before inserting the replacement O-rings, clean the retaining slots with a cleaning solution.</p>
59	Insert the rod guide sleeve (13) together with the I/DWR rings (9), circlips (76), U ring (30) into the flange (37).
60	<p>Insert and fix the nut (66) according to the following tightening torque:</p> <ul style="list-style-type: none"> 6": tab. 9.71 8": tab. 9.72
61	Undo and remove the screws (60).
62	Remove the shaft collar (14) from the intermediate body (16).
63	Undo and remove the screws (62) of the spacer (17).
64	Remove the shaft collar (15).
65	<p>Remove the balancing diaphragm (29) and replace it, taking care to lubricate it with synthetic grease.</p> <p>! NOTICE! Before inserting the replacement diaphragm, clean the retaining slots with a cleaning solution.</p>
66	Fit the shaft collar (15).
67	<p>Insert and fix the screws (62) according to the following tightening torque:</p> <ul style="list-style-type: none"> 6": tab. 9.71 8": tab. 9.72 <p>! NOTICE! Tighten the screws according to the cross diagram in paragraph 9.4.2.2.</p>

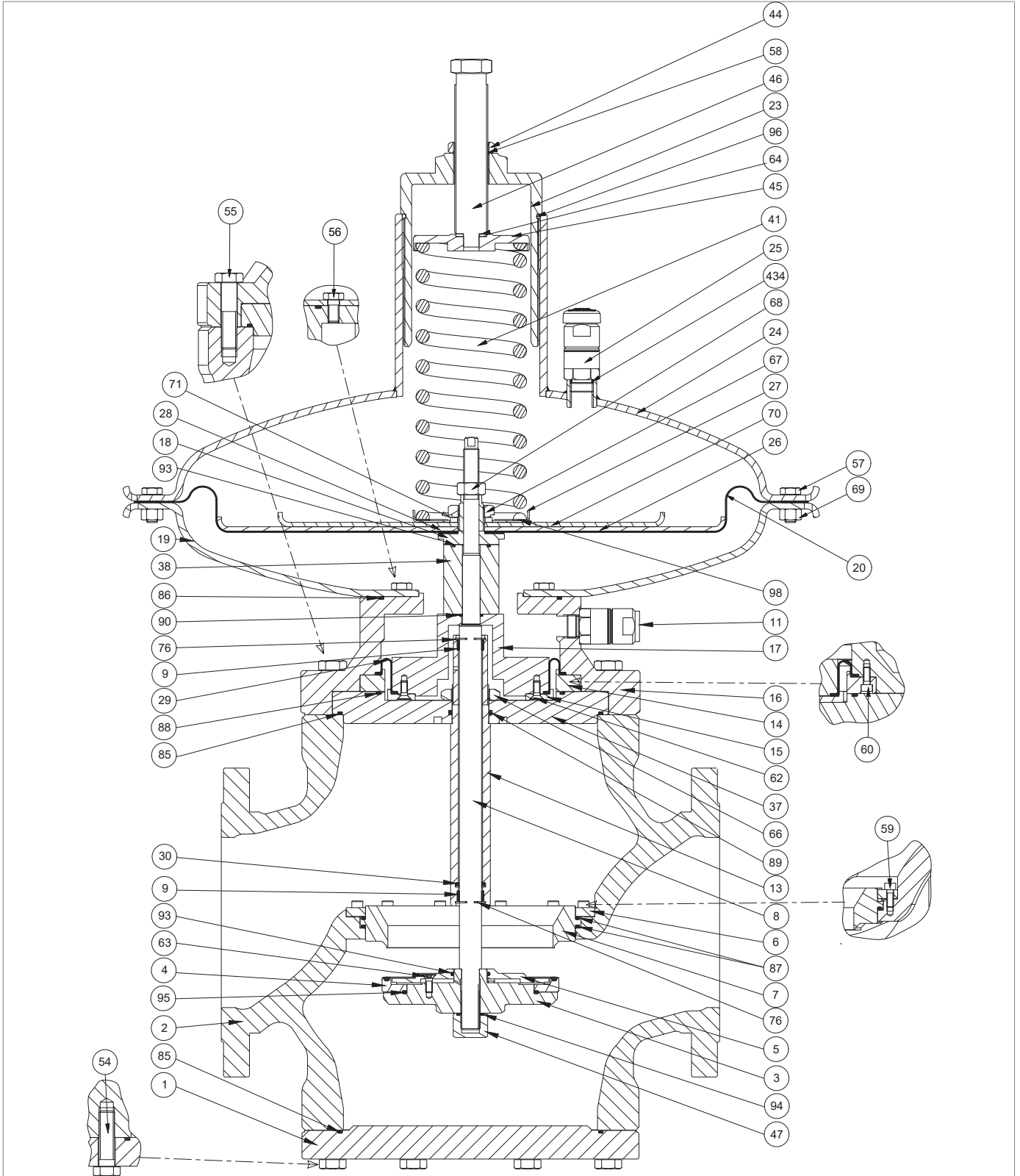



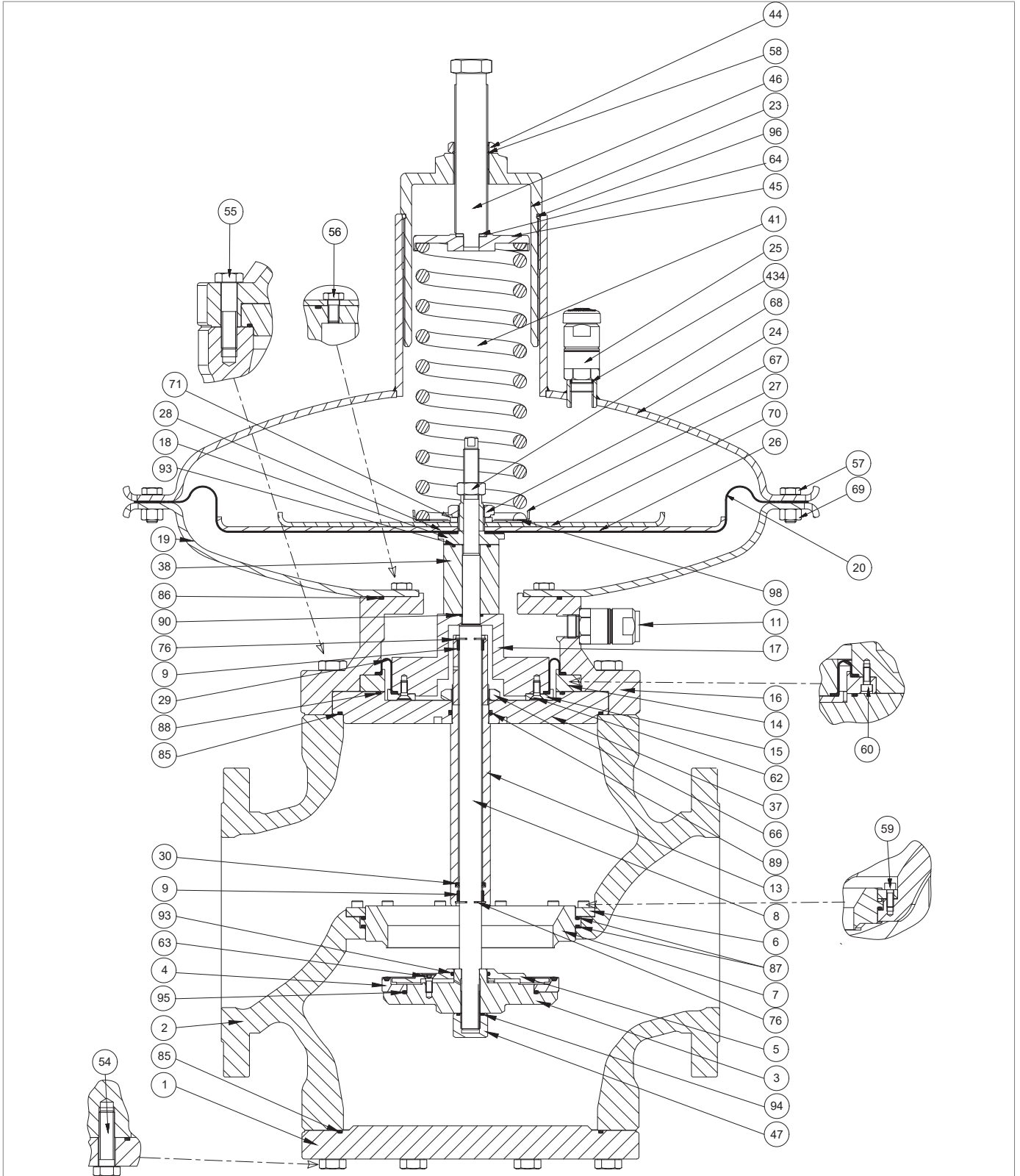

NORVAL Regulator 6" - 8" (head 630)

Step	Action
68	Fit the shaft collar (14).
69	Fit the flange assembly (9, 13, 16, 30, 37, 66, 76, 85, 88, 89) into the intermediate body (16).
70	<p>Insert and fix the screws (60) according to the following tightening torque:</p> <ul style="list-style-type: none"> • 6": tab. 9.71 • 8": tab. 9.72 <div style="border: 1px solid black; padding: 5px;"> <p>! NOTICE!</p> <p>Tighten the screws according to the cross diagram in paragraph 9.4.2.2.</p> </div>
71	Undo and remove the screws (59).
72	Remove the ring (6).
73	Pull out the valve seat (7) from the body (2).
74	<p>Remove the O-rings (87) from the valve seat (7) and replace them, taking care to lubricate them with synthetic grease.</p> <div style="border: 1px solid black; padding: 5px;"> <p>! NOTICE!</p> <p>Before inserting the replacement O-rings, clean the retaining slots with a cleaning solution.</p> </div>
75	Fit the valve seat (7) in the body (2).
76	Fit the shaft collar (6).
77	<p>Insert and fix the screws (59) according to the following tightening torque:</p> <ul style="list-style-type: none"> • 6": tab. 9.71 • 8": tab. 9.72 <div style="border: 1px solid black; padding: 5px;"> <p>! NOTICE!</p> <p>Tighten the screws according to the cross diagram in paragraph 9.4.2.2.</p> </div>
78	Fit the intermediate body (16) into the body (2).
79	<p>Insert and fix the screws (55) according to the following tightening torque:</p> <ul style="list-style-type: none"> • 6": tab. 9.71 • 8": tab. 9.72 <div style="border: 1px solid black; padding: 5px;"> <p>! NOTICE!</p> <p>Tighten the screws according to the cross diagram in paragraph 9.4.2.2.</p> </div>
80	<p>Remove the O-ring (90) and replace it, taking care to lubricate it with synthetic grease.</p> <div style="border: 1px solid black; padding: 5px;"> <p>! NOTICE!</p> <p>Before inserting the replacement O-ring, clean the retaining slots with a cleaning solution.</p> </div>
81	Position the spacer (38) together with the O-ring (93).
82	<p>Remove the O-ring (86) and replace it, taking care to lubricate it with synthetic grease.</p> <div style="border: 1px solid black; padding: 5px;"> <p>! NOTICE!</p> <p>Before inserting the replacement O-ring, clean the retaining slots with a cleaning solution.</p> </div>
83	Fit the bottom cover (19).



NORVAL Regulator 6'' - 8'' (head 630)

Step	Action
84	Insert and fix the screws (56) according to the following tightening torque: <ul style="list-style-type: none"> • 6": tab. 9.71 • 8": tab. 9.72 <div style="border: 1px solid black; padding: 5px;">  NOTICE! Tighten the screws according to the cross diagram in paragraph 9.4.2.2. </div>
85	Fit the diaphragm assembly (18, 20, 26, 27, 28, 67, 70, 98).
86	Insert the rod (8) into the rod guide sleeve (13) from the bottom upwards.
87	Insert the lock nut (68).
88	Align the hole of the diaphragm (20) with the bottom cover holes (19)
89	Insert and fix the nut (68) according to the following tightening torque: <ul style="list-style-type: none"> • 6": tab. 9.71 • 8": tab. 9.72 <div style="border: 1px solid black; padding: 5px;">  NOTICE! During this phase, keep the rod (8) and the diaphragm support (18) still. </div>
90	Fit the top cover (24).
91	Insert and fix the screws (57) together with the nuts (69) according to the following tightening torque: <ul style="list-style-type: none"> • 6": tab. 9.71 • 8": tab. 9.72 <div style="border: 1px solid black; padding: 5px;">  NOTICE! Tighten the screws according to the cross diagram in paragraph 9.4.2.2. </div>
92	Screw the adjustment assembly (3, 4, 95, 63, 93, 5) into the rod (8) clockwise.
93	Insert and fix the nut (47) together with the O-ring (94) according to the following tightening torques: <ul style="list-style-type: none"> • 6": tab. 9.71 • 8": tab. 9.72
94	Fit the lower flange (1).
95	Insert and fix the screws (54) according to the following tightening torque: <ul style="list-style-type: none"> • 6": tab. 9.71 • 8": tab. 9.72 <div style="border: 1px solid black; padding: 5px;">  NOTICE! Tighten the screws according to the cross diagram in paragraph 9.4.2.2. </div>
96	Insert the regulation spring (41).
97	Insert the spring guide (45) together with the disc (64).
98	Insert and fix the cap (23), together with the O-rings (58, 96), the adjustment screw (46) and the lock nut (44).

Tab. 9.103.

 **WARNING!**

Ensure that all parts have been fitted correctly.

9.4.4.14 - NORVAL REGULATOR 6" - 8" (HEAD 658)

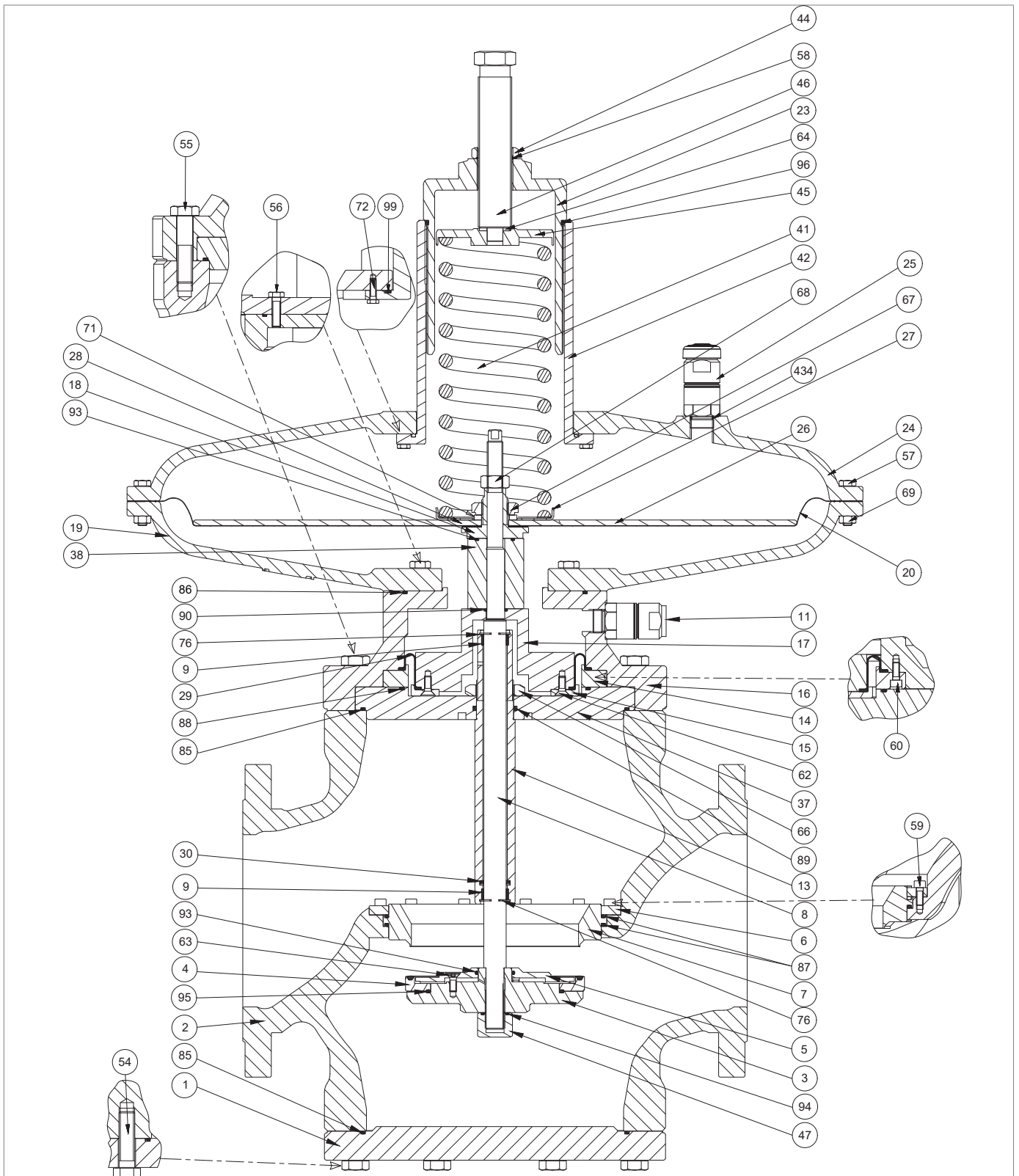





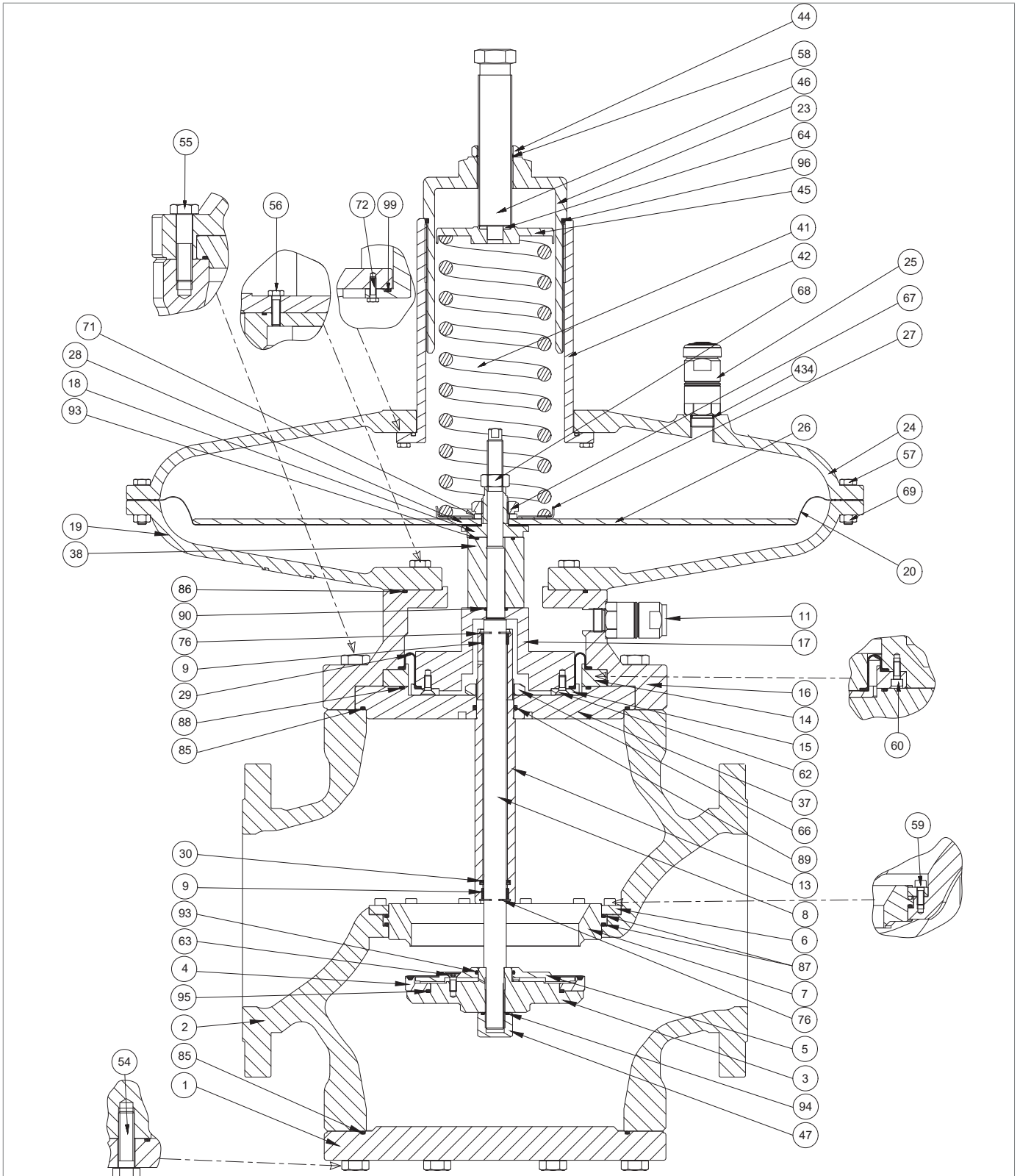

Fig. 9.47. NORVAL Regulator 6" - 8" (head 658)

Step	Action
1	 ATTENTION! In the presence of the ER device, after step 11 and 99, refer to paragraph 9.4.5 for maintenance.
2	Unscrew the lock nut (44).
3	Undo and remove the adjustment screw (46).
4	Remove the O-ring (58) from the lock nut (44) and replace it, taking care to lubricate it with synthetic grease.  NOTICE! Before inserting the replacement O-ring, clean the retaining slots with a cleaning solution.
5	Unscrew and remove the cap (23).
6	Remove the O-ring (96) from the cap (23) and replace it, taking care to lubricate it with synthetic grease.  NOTICE! Before inserting the replacement O-ring, clean the retaining slots with a cleaning solution.
7	Remove the spring guide (45) together with the disc (64).
8	Remove the setting spring (41).
9	Unscrew and remove the anti-pumping valve (25) from the top cover (24).
10	Remove the O-ring (434) and replace it, taking care to lubricate it with synthetic grease.  NOTICE! Before inserting the replacement O-ring, clean the retaining slots with a cleaning solution.
11	Position and secure the anti-pumping valve (25) in the top cover (24).
12	Undo and remove the screws (54).
13	Remove the bottom flange (1), taking care to support it.
14	Remove the O-ring (85) and replace it, taking care to lubricate it with synthetic grease.  NOTICE! Before inserting the replacement O-ring, clean the retaining slots with a cleaning solution.
15	Unscrew the nut (47).
16	Remove the O-ring (94) and replace it, taking care to lubricate it with synthetic grease.  NOTICE! Before inserting the replacement O-ring, clean the retaining slots with a cleaning solution.
17	Unscrew the adjustment assembly (3, 4, 95, 63, 93, 5) from the rod (8) anti-clockwise, and place it on a shock-proof surface.
18	Undo and remove the screws (63).
19	Remove the protection disk (5) from the gasket support (3).
20	Remove the reinforced gasket (4) from the gasket support (3) and replace it







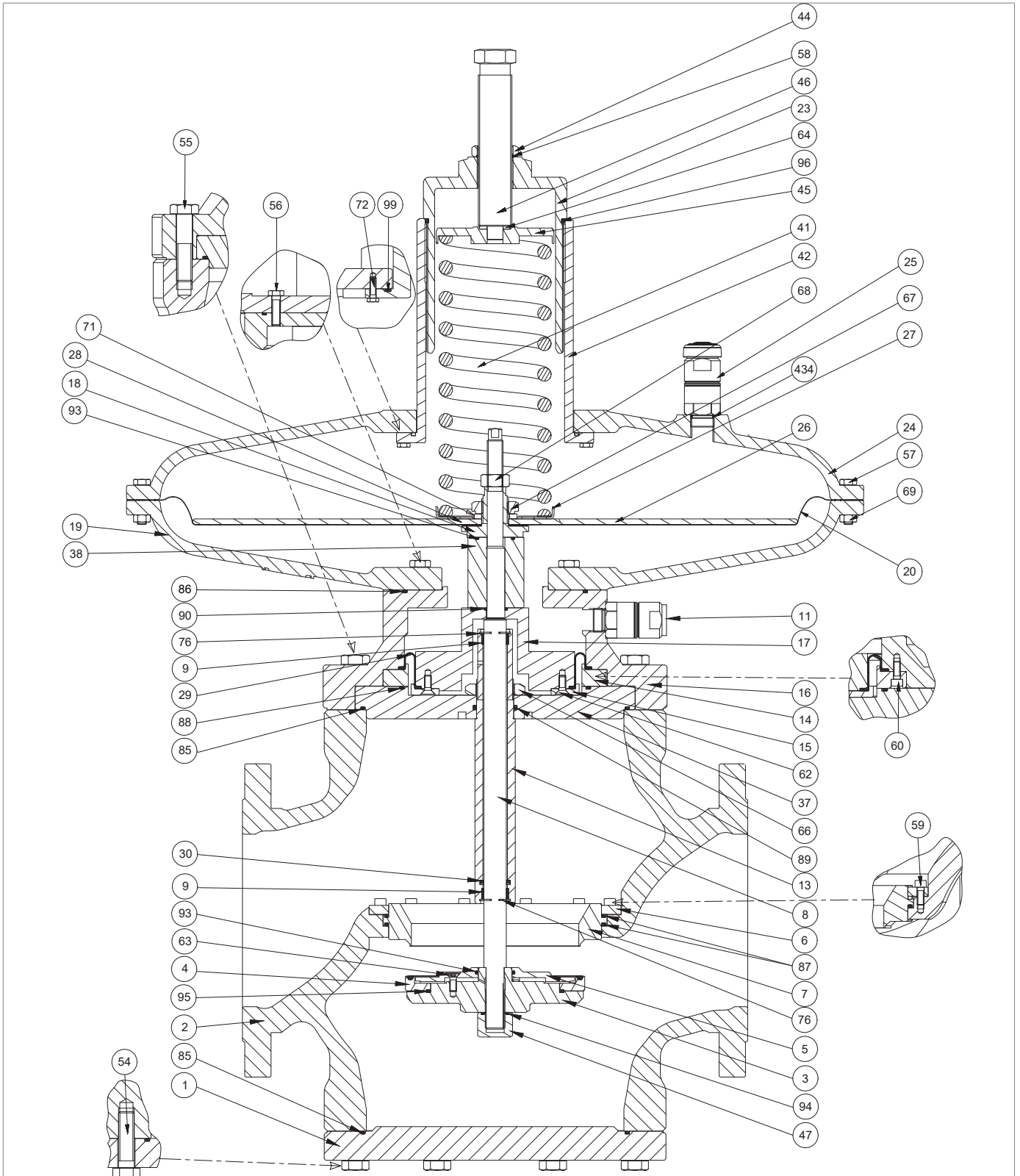

NORVAL Regulator 6" - 8" (head 658)

Step	Action
21	Remove the O-rings (93, 95) from the gasket support (3) and replace them, taking care to lubricate them with synthetic grease. NOTICE! Before inserting the replacement O-rings, clean the retaining slots with a cleaning solution.
22	Fit the reinforced gasket (4).
23	Place the protection disc (5) in the gasket support (3).
24	Undo and remove the screws (57) together with the nuts (69).
25	Remove the top cover (24).
26	Undo and remove the screws (72).
27	Pull out the sleeve (42) from the cover (24).
28	Remove the O-ring (99) from the cover (24) and replace it, taking care to lubricate it with synthetic grease. NOTICE! Before inserting the replacement O-ring, clean the retaining slots with a cleaning solution.
30	Fit the sleeve (42) in the cover (24).
31	Insert and fix the screws (72) according to the following tightening torques <ul style="list-style-type: none"> 6": tab. 9.73 8": tab. 9.74 NOTICE! Tighten the screws according to the cross diagram in paragraph 9.4.2.2.
32	Remove the lock nut (68). NOTICE! During this phase, keep the rod (8) still.
33	Pull out the rod (8) from the top downwards.
34	Remove the diaphragm assembly (18, 20, 26, 27, 28, 67).
35	Unscrew and remove the nut (67). NOTICE! During this phase, keep the diaphragm support (18) still.
36	Remove the spring guide disc (27).
37	Remove the protection discs (26).
38	Remove and replace the diaphragm (20).
39	Remove the oil seal (28) and replace it.
40	Fit the oil seal (28).
41	Fit the diaphragm (20).
42	Fit the protection discs (26).
43	Fit the spring guide disc (27).



NORVAL Regulator 6" - 8" (head 658)

Step	Action
44	Insert and fix the nut (67) according to the following tightening torques <ul style="list-style-type: none"> 6": tab. 9.73 8": tab. 9.74 <div style="border: 1px solid black; padding: 5px;">  NOTICE! During this phase, keep the diaphragm support (18) still. </div>
45	Remove the spacer (38) from the rod (8).
46	Remove the O-ring (93) from the spacer (38) and replace it, taking care to lubricate it with synthetic grease. <div style="border: 1px solid black; padding: 5px;">  NOTICE! Before inserting the replacement O-ring, clean the retaining slots with a cleaning solution. </div>
47	Undo and remove the screws (56).
48	Remove the bottom cover (19) from the intermediate body (16).
49	Undo and remove the screws (55).
50	Remove the intermediate body assembly (9, 11, 13, 15, 17, 29, 30, 37, 62, 66, 76, 85, 88, 89). <div style="border: 1px solid black; padding: 5px;">  NOTICE! Put the assembly back on a shockproof surface. </div>
51	Pull out the flange (37) from the intermediate body (16).
52	Unscrew and remove the nut (66) from the rod guide sleeve (13).
53	Pull out the rod guide sleeve (13) from the flange spacer (37). <div style="background-color: yellow; padding: 5px;">  ATTENTION! In the presence of the SN slam-shut valve, see paragraph 9.4.6 for maintenance. </div>
54	Remove the upper circlip (76).
55	Remove and replace the upper I/DWR ring (9). <div style="border: 1px solid black; padding: 5px;">  NOTICE! Before inserting the replacement I/DWR ring, clean the retaining slots with a cleaning solution. </div>
56	Fit the upper circlip (76).
57	Remove the lower circlip (76).
58	Remove the lower I/DWR ring (9).
59	Remove and replace the lip seal (30).
60	Replace the lower I/DWR ring (9). <div style="border: 1px solid black; padding: 5px;">  NOTICE! Before inserting the replacement I/DWR ring, clean the retaining slots with a cleaning solution. </div>
61	Fit the lower circlip (76).
62	Remove and replace the O-rings (85, 88, 89), taking care to lubricate them with synthetic grease. <div style="border: 1px solid black; padding: 5px;">  NOTICE! Before inserting the replacement O-rings, clean the retaining slots with a cleaning solution. </div>

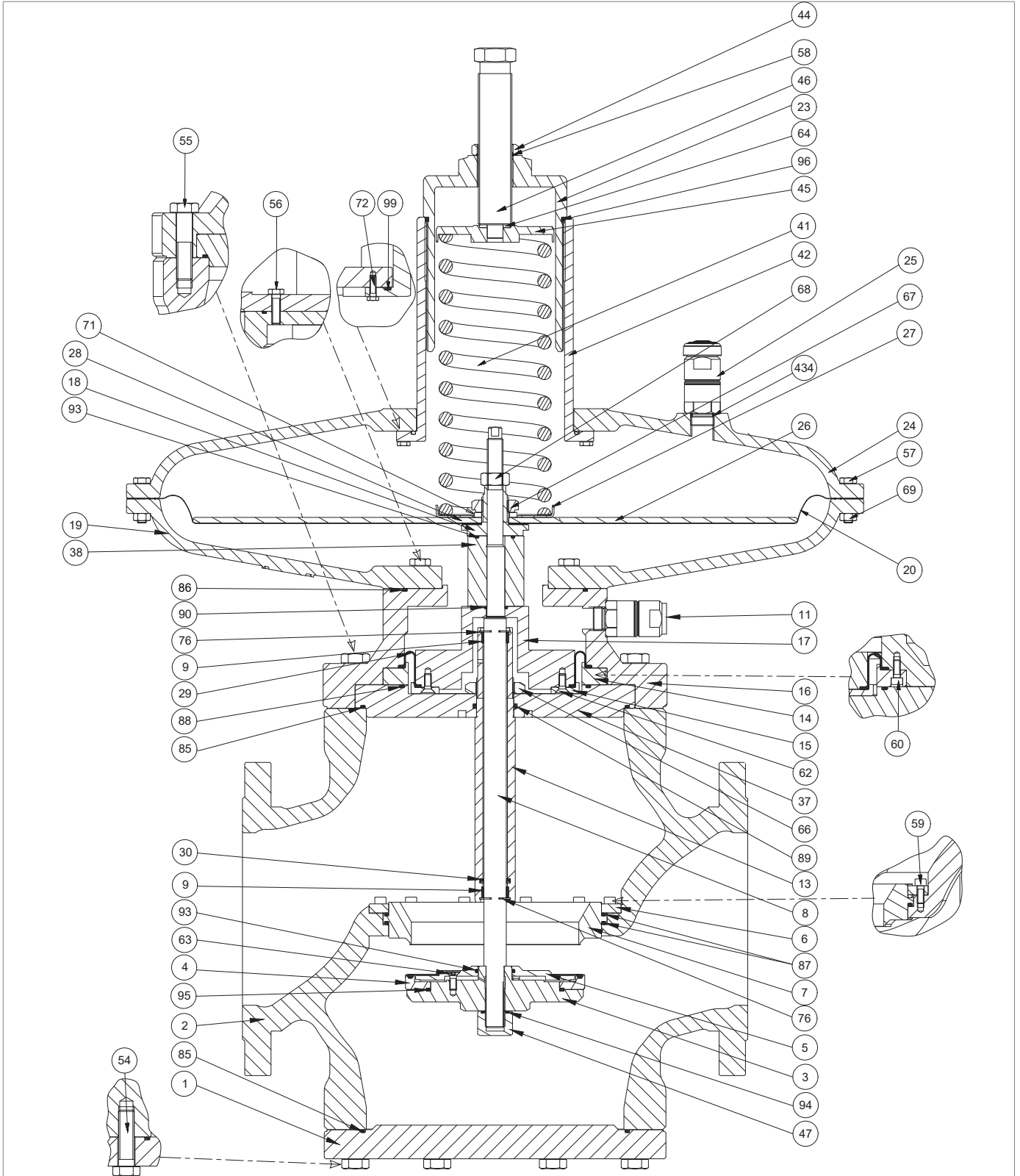





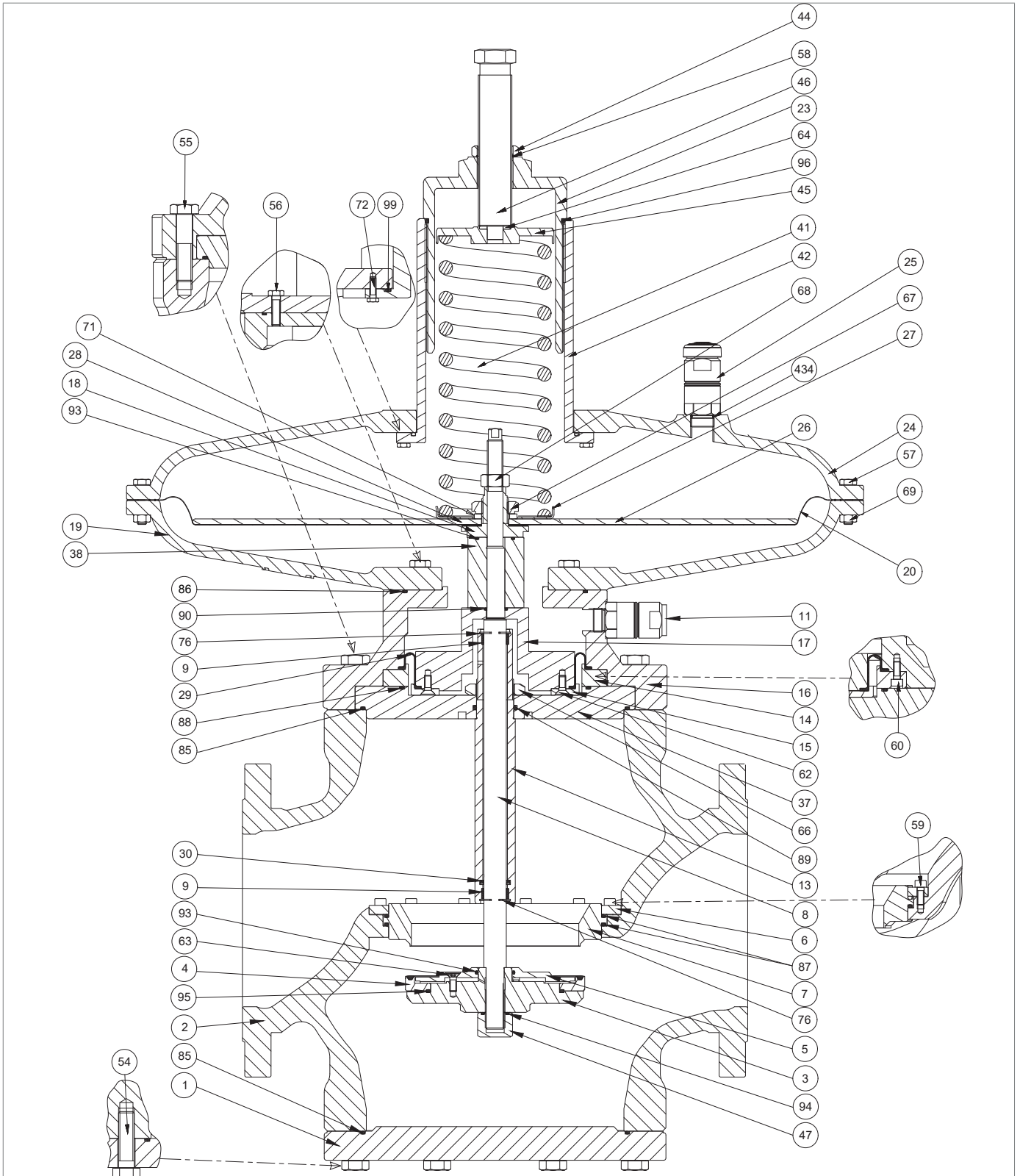



NORVAL Regulator 6'' - 8'' (head 658)

Step	Action
63	Insert the rod guide sleeve (13) together with the lower I/DWR ring (9), the upper I/DWR ring (9), the lower circlip (76), the upper circlip (76) the lip seal (30) into the flange (37).
64	Insert and fix the nut (66) according to the following tightening torques: <ul style="list-style-type: none"> • 6": tab. 9.73 • 8": tab. 9.74
65	Undo and remove the screws (60).
66	Remove the shaft collar (14) from the intermediate body (16).
67	Undo and remove the screws (62) of the spacer (17).
68	Remove the shaft collar (15).
69	Remove the balancing diaphragm (29) and replace it, taking care to lubricate it with synthetic grease. <div style="border: 1px solid black; padding: 5px;">NOTICE!</div> <p>Before inserting the replacement diaphragm, clean the retaining slots with a cleaning solution.</p>
70	Fit the shaft collar (15).
71	Insert and fix the screws (62) according to the following tightening torques: <ul style="list-style-type: none"> • 6": tab. 9.73 • 8": tab. 9.74 <div style="border: 1px solid black; padding: 5px;">NOTICE!</div> <p>Tighten the screws according to the cross diagram in paragraph 9.4.2.2.</p>
72	Fit the shaft collar (14).
73	Position the flange (37), together with the upper and lower I/DWR rings (9), the rod guide sleeve (13), the lip seal (30), the nut (66), the upper and lower circlips (76), the O-rings (88, 89) into the intermediate body (16).
74	Insert and fix the screws (60) according to the following tightening torques: <ul style="list-style-type: none"> • 6": tab. 9.73 • 8": tab. 9.74 <div style="border: 1px solid black; padding: 5px;">NOTICE!</div> <p>Tighten the screws according to the cross diagram in paragraph 9.4.2.2.</p>
75	Fit the flange (37) into the intermediate body (16).
76	Undo and remove the screws (59).
77	Remove the shaft collar (6).
78	Pull out the valve seat (7) from the body (2).
79	Remove the O-rings (87) from the valve seat (7) and replace them, taking care to lubricate them with synthetic grease. <div style="border: 1px solid black; padding: 5px;">NOTICE!</div> <p>Before inserting the replacement O-rings, clean the retaining slots with a cleaning solution.</p>
80	Fit the valve seat (7) in the body (2).
81	Fit the shaft collar (6).



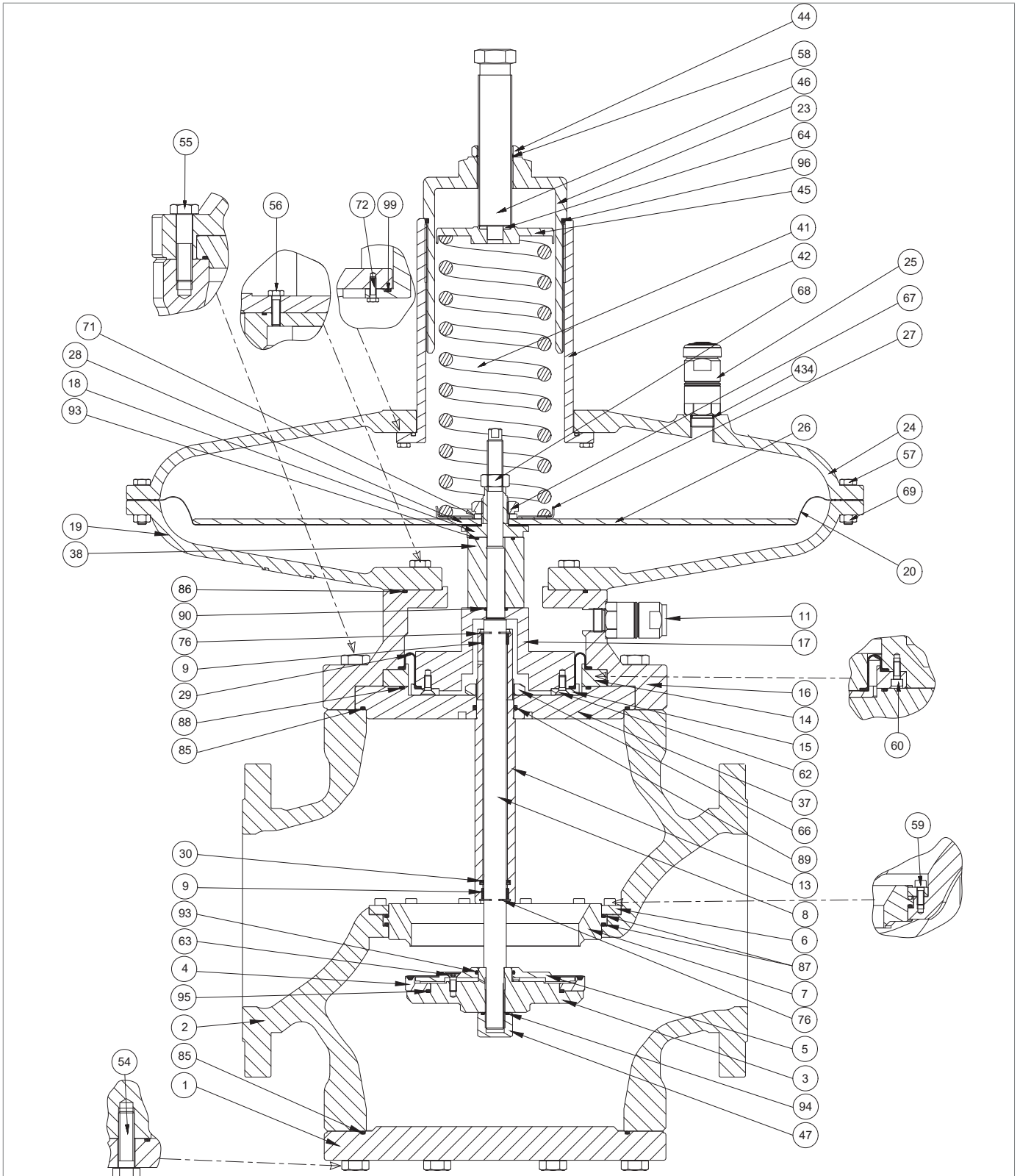

NORVAL Regulator 6" - 8" (head 658)

Step	Action
82	<p>Insert and fix the screws (59) according to the following tightening torques:</p> <ul style="list-style-type: none"> • 6": tab. 9.73 • 8": tab. 9.74 <div style="border: 1px solid black; padding: 5px;">  NOTICE! </div> <p>Tighten the screws according to the cross diagram in paragraph 9.4.2.2.</p>
83	Fit the intermediate body assembly (9, 11, 13, 15, 17, 29, 30, 37, 62, 66, 76, 85, 88, 89) into the body (2).
84	<p>Insert and fix the screws (55) according to the following tightening torques:</p> <ul style="list-style-type: none"> • 6": tab. 9.73 • 8": tab. 9.74 <div style="border: 1px solid black; padding: 5px;">  NOTICE! </div> <p>Tighten the screws according to the cross diagram in paragraph 9.4.2.2.</p>
85	<p>Remove the O-ring (90) and replace it, taking care to lubricate it with synthetic grease.</p> <div style="border: 1px solid black; padding: 5px;">  NOTICE! </div> <p>Before inserting the replacement O-ring, clean the retaining slots with a cleaning solution.</p>
86	Position the spacer (38) together with the O-ring (93).
87	<p>Remove the O-ring (86) and replace it, taking care to lubricate it with synthetic grease.</p> <div style="border: 1px solid black; padding: 5px;">  NOTICE! </div> <p>Before inserting the replacement O-ring, clean the retaining slots with a cleaning solution.</p>
88	Fit the bottom cover (19).
89	<p>Insert and fix the screws (56) according to the following tightening torques:</p> <ul style="list-style-type: none"> • 6": tab. 9.73 • 8": tab. 9.74 <div style="border: 1px solid black; padding: 5px;">  NOTICE! </div> <p>Tighten the screws according to the cross diagram in paragraph 9.4.2.2.</p>
90	<p>Fit the diaphragm assembly (18, 20, 26, 27, 67).</p> <div style="border: 1px solid black; padding: 5px;">  NOTICE! </div> <p>Centre the diaphragm support hole (18) with the hole of the spacer (38).</p>
91	Insert the rod (8) into the rod guide sleeve (13) from the bottom upwards.
92	<p>Insert the lock nut (68).</p> <div style="border: 1px solid black; padding: 5px;">  NOTICE! </div> <p>Align the housing of the rod fixing spanner (8) and the housing of the diaphragm support fixing spanner (18).</p>
93	Align the hole of the diaphragm (20) with the bottom cover holes (19).
94	<p>Insert the locking nut (68) according to the following tightening torques:</p> <ul style="list-style-type: none"> • 6": tab. 9.73 • 8": tab. 9.74 <div style="border: 1px solid black; padding: 5px;">  NOTICE! </div> <ul style="list-style-type: none"> • During this phase, keep the rod (8) and the diaphragm support (18) still • Tighten the screws according to the cross diagram in paragraph 9.4.2.2.



NORVAL Regulator 6" - 8" (head 658)

Step	Action
95	Fit the top cover (24).
96	Insert and fix the screws (57) together with the nuts (69) according to the following tightening torques: <ul style="list-style-type: none"> • 6": tab. 9.73 • 8": tab. 9.74 <div style="border: 1px solid blue; padding: 5px; margin-top: 5px;">  NOTICE! Tighten the screws according to the cross diagram in paragraph 9.4.2.2. </div>
97	Screw the adjustment assembly (3, 4, 95, 63, 93, 5) into the rod (8) clockwise.
98	Insert and fix the nut (47) together with the O-ring (94) according to the following tightening torques: <ul style="list-style-type: none"> • 6": tab. 9.73 • 8": tab. 9.74
99	Fit the lower flange (1).
100	Insert and fix the screws (54) according to the following tightening torques: <ul style="list-style-type: none"> • 6": tab. 9.73 • 8": tab. 9.74 <div style="border: 1px solid blue; padding: 5px; margin-top: 5px;">  NOTICE! Tighten the screws according to the cross diagram in paragraph 9.4.2.2. </div>
101	Insert the regulation spring (41).
102	Insert the spring guide (45) together with the disc (64).
103	Insert and fix the cap (23), together with the O-rings (58, 96), the adjustment screw (46) and the lock nut (44).

 **WARNING!**

Ensure that all parts have been fitted correctly.

9.4.4.15 - NORVAL REGULATOR 6" - 8" (HEAD 817)

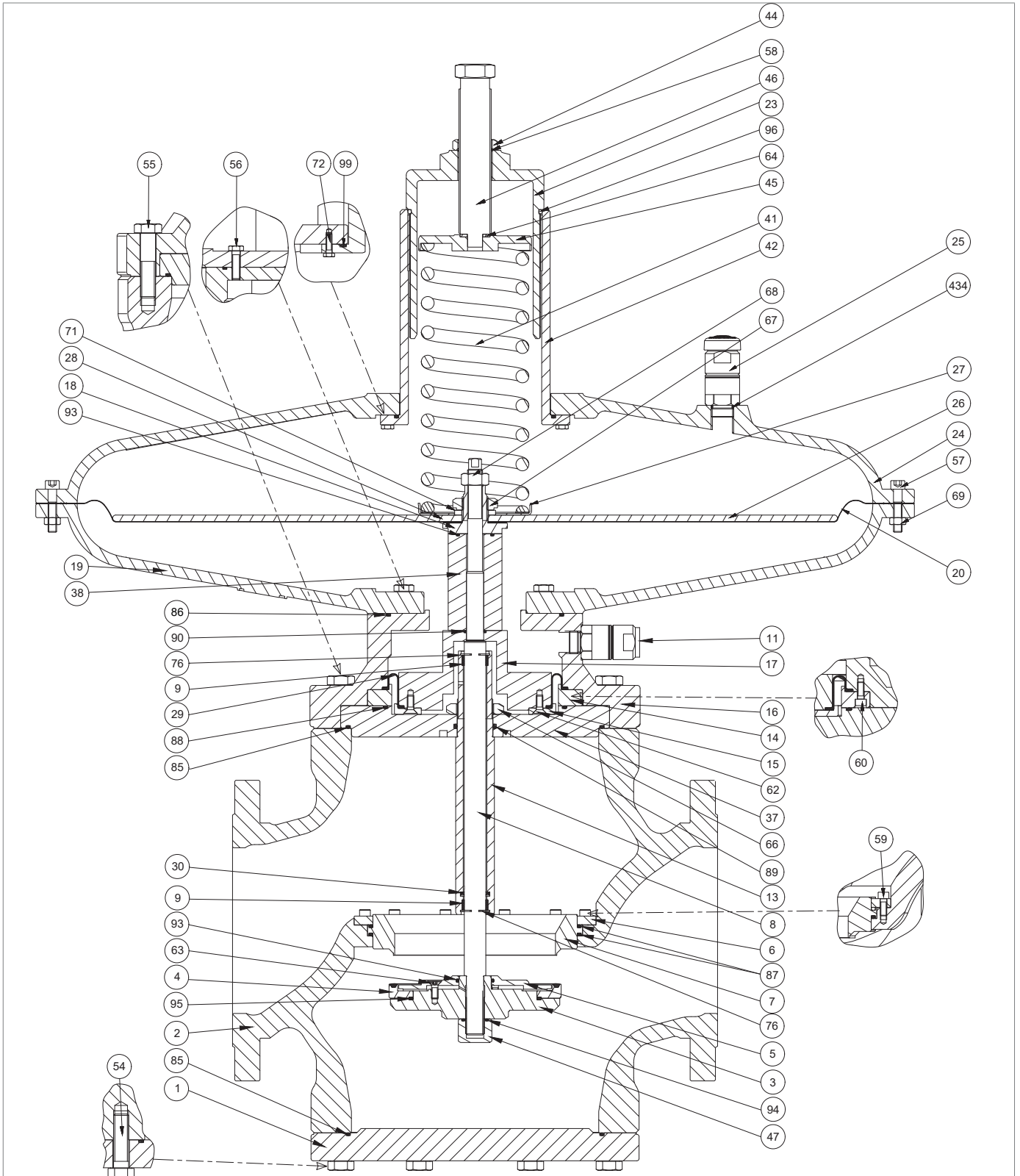





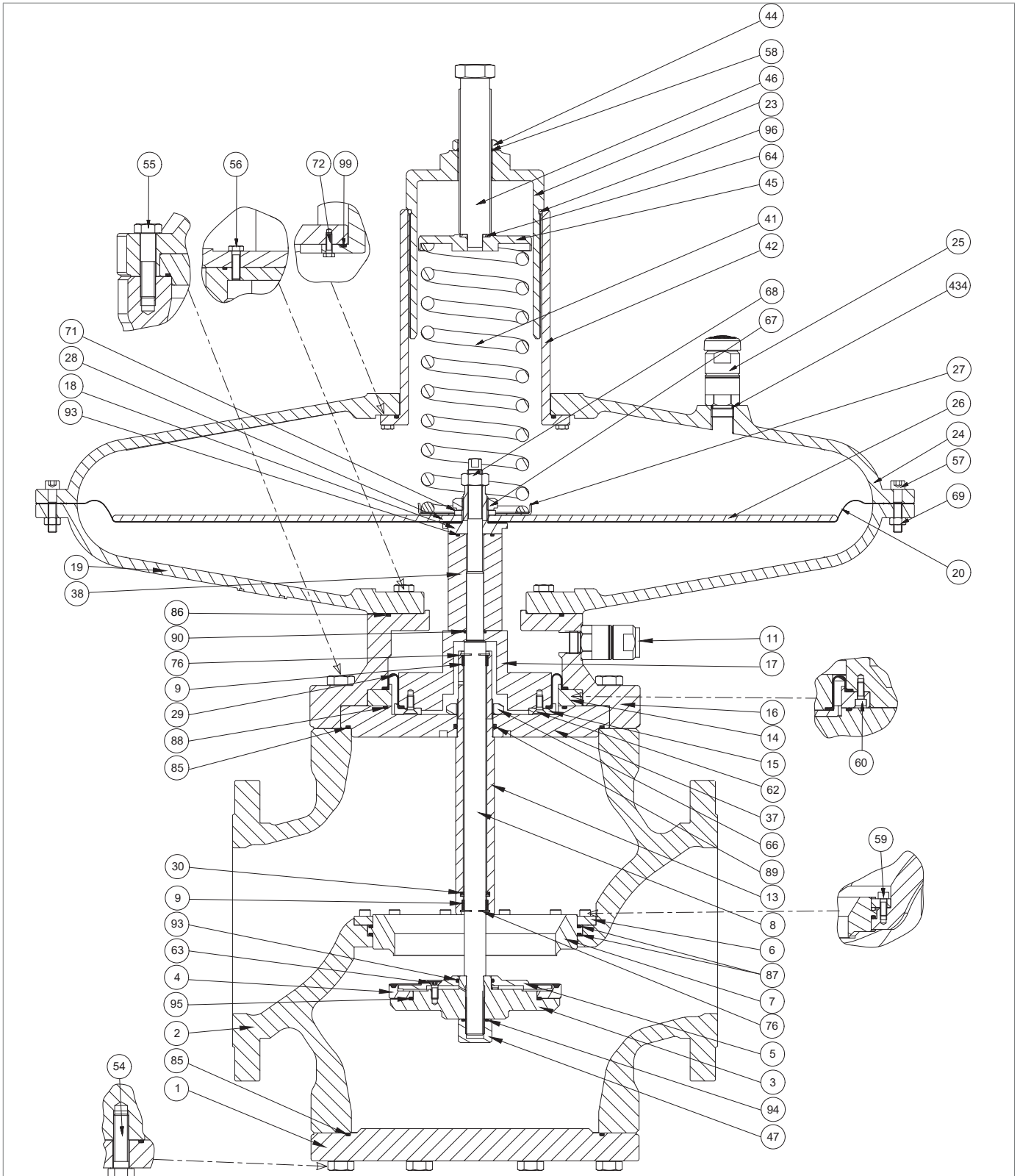

Fig. 9.48. NORVAL Regulator 6" - 8" (head 817)

Step	Action
1	 ATTENTION! In the presence of the ER device, after step 11 and 96, refer to paragraph 9.4.5 for maintenance.
2	Unscrew the lock nut (44).
3	Undo and remove the adjustment screw (46).
4	Remove the O-ring (58) from the lock nut (44) and replace it, taking care to lubricate it with synthetic grease.  NOTICE! Before inserting the replacement O-ring, clean the retaining slots with a cleaning solution.
5	Unscrew and remove the cap (23).
6	Remove the O-ring (96) from the cap (23) and replace it, taking care to lubricate it with synthetic grease.  NOTICE! Before inserting the replacement O-ring, clean the retaining slots with a cleaning solution.
7	Remove the spring guide (45) together with the disc (64).
8	Remove the setting spring (41).
9	Unscrew and remove the anti-pumping valve (25) from the top cover (24).
10	Remove the O-ring (434) and replace it, taking care to lubricate it with synthetic grease.  NOTICE! Before inserting the replacement O-ring, clean the retaining slots with a cleaning solution.
11	Position and secure the anti-pumping valve (25) in the top cover (24).
12	Undo and remove the screws (54).
13	Remove the bottom flange (1), taking care to support it.
14	Remove the O-ring (85) and replace it, taking care to lubricate it with synthetic grease.  NOTICE! Before inserting the replacement O-ring, clean the retaining slots with a cleaning solution.
15	Unscrew the nut (47).
16	Remove the O-ring (94) and replace it, taking care to lubricate it with synthetic grease.  NOTICE! Before inserting the replacement O-ring, clean the retaining slots with a cleaning solution.
17	Unscrew the adjustment assembly (3, 4, 95, 63, 93, 5) from the rod (8) anti-clockwise, and place it on a shock-proof surface.
18	Undo and remove the screws (63).
19	Remove the protection disk (5) from the gasket support (3).
20	Remove the reinforced gasket (4) from the gasket support (3) and replace it







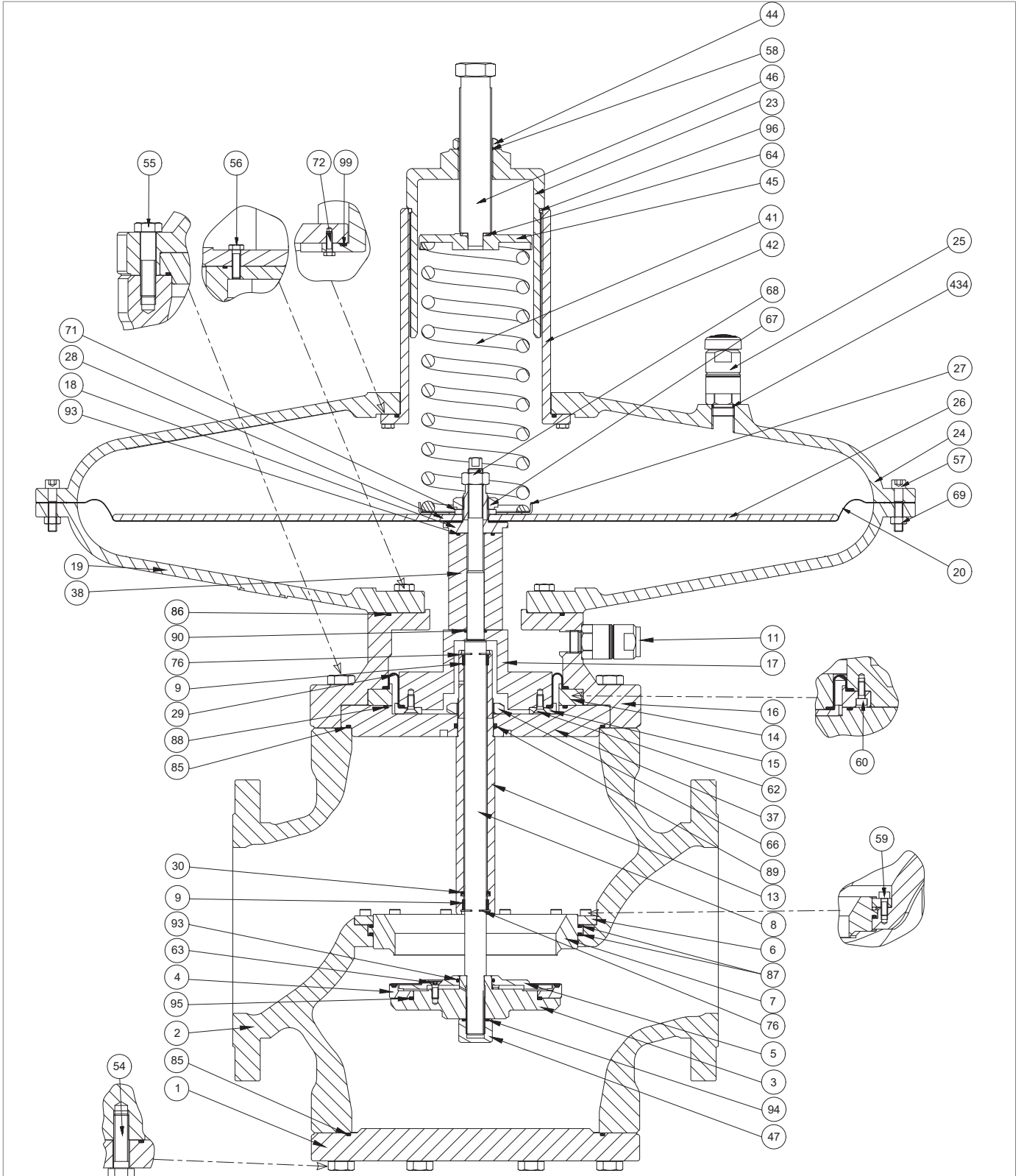

NORVAL Regulator 6'' - 8'' (head 817)

Step	Action
21	Remove the O-rings (93, 95) from the gasket support (3) and replace them, taking care to lubricate them with synthetic grease. NOTICE! Before inserting the replacement O-rings, clean the retaining slots with a cleaning solution.
22	Fit the reinforced gasket (4).
23	Place the protection disc (5) in the gasket support (3).
24	Undo and remove the screws (57) together with the nuts (69).
25	Remove the top cover (24).
26	Undo and remove the screws (72).
27	Pull out the sleeve (42) from the cover (24).
28	Remove the O-ring (99) from the cover (24) and replace it, taking care to lubricate it with synthetic grease. NOTICE! Before inserting the replacement O-ring, clean the retaining slots with a cleaning solution.
29	Fit the sleeve (42) in the cover (24).
30	Insert and fix the nut (72) according to the following tightening torque <ul style="list-style-type: none"> 6": tab. 9.75 8": tab. 9.76 NOTICE! During this phase, keep the diaphragm support (18) still.
31	Remove the lock nut (68). NOTICE! During this phase, keep the rod (8) still.
32	Pull out the rod (8) from the top downwards.
33	Remove the diaphragm assembly (18, 20, 26, 27, 28, 67).
34	Unscrew and remove the nut (67). NOTICE! During this phase, keep the diaphragm support (18) still.
35	Remove the spring guide disc (27).
36	Remove the protection discs (26).
37	Remove and replace the diaphragm (20).
38	Remove the oil seal (28) and replace it.
39	Fit the oil seal (28).
40	Fit the diaphragm (20).
41	Fit the protection discs (26).
42	Fit the spring guide disc (27).



NORVAL Regulator 6'' - 8'' (head 817)

Step	Action
43	Insert and fix the nut (67) according to the following tightening torques <ul style="list-style-type: none"> • 6": tab. 9.75 • 8": tab. 9.76 <div style="border: 1px solid black; padding: 5px;">  NOTICE! During this phase, keep the diaphragm support (18) still. </div>
44	Remove the spacer (38) from the rod (8).
45	Remove the O-ring (93) from the spacer (38) and replace it, taking care to lubricate it with synthetic grease. <div style="border: 1px solid black; padding: 5px;">  NOTICE! Before inserting the replacement O-ring, clean the retaining slots with a cleaning solution. </div>
46	Undo and remove the screws (56).
47	Remove the bottom cover (19) from the intermediate body (16).
48	Undo and remove the screws (55).
49	Remove the intermediate body assembly (9, 11, 13, 15, 17, 29, 30, 37, 62, 66, 76, 85, 88, 89). <div style="border: 1px solid black; padding: 5px;">  NOTICE! Put the assembly back on a shockproof surface. </div>
50	Pull out the flange (37) from the intermediate body (16).
51	Unscrew and remove the nut (66) from the rod guide sleeve (13).
52	Pull out the rod guide sleeve (13) from the flange spacer (37). <div style="background-color: yellow; padding: 5px;">  ATTENTION! In the presence of the SN slam-shut valve, see paragraph 9.4.6 for maintenance. </div>
53	Remove the upper circlip (76).
54	Remove and replace the upper I/DWR ring (9). <div style="border: 1px solid black; padding: 5px;">  NOTICE! Before inserting the replacement I/DWR ring, clean the retaining slots with a cleaning solution. </div>
55	Fit the upper circlip (76).
56	Remove the lower circlip (76).
57	Remove the lower I/DWR ring (9).
58	Remove and replace the lip seal (30).
59	Replace the lower I/DWR ring (9). <div style="border: 1px solid black; padding: 5px;">  NOTICE! Before inserting the replacement I/DWR ring, clean the retaining slots with a cleaning solution. </div>
60	Fit the lower circlip (76).
61	Remove and replace the O-rings (85, 88, 89), taking care to lubricate them with synthetic grease. <div style="border: 1px solid black; padding: 5px;">  NOTICE! Before inserting the replacement O-rings, clean the retaining slots with a cleaning solution. </div>

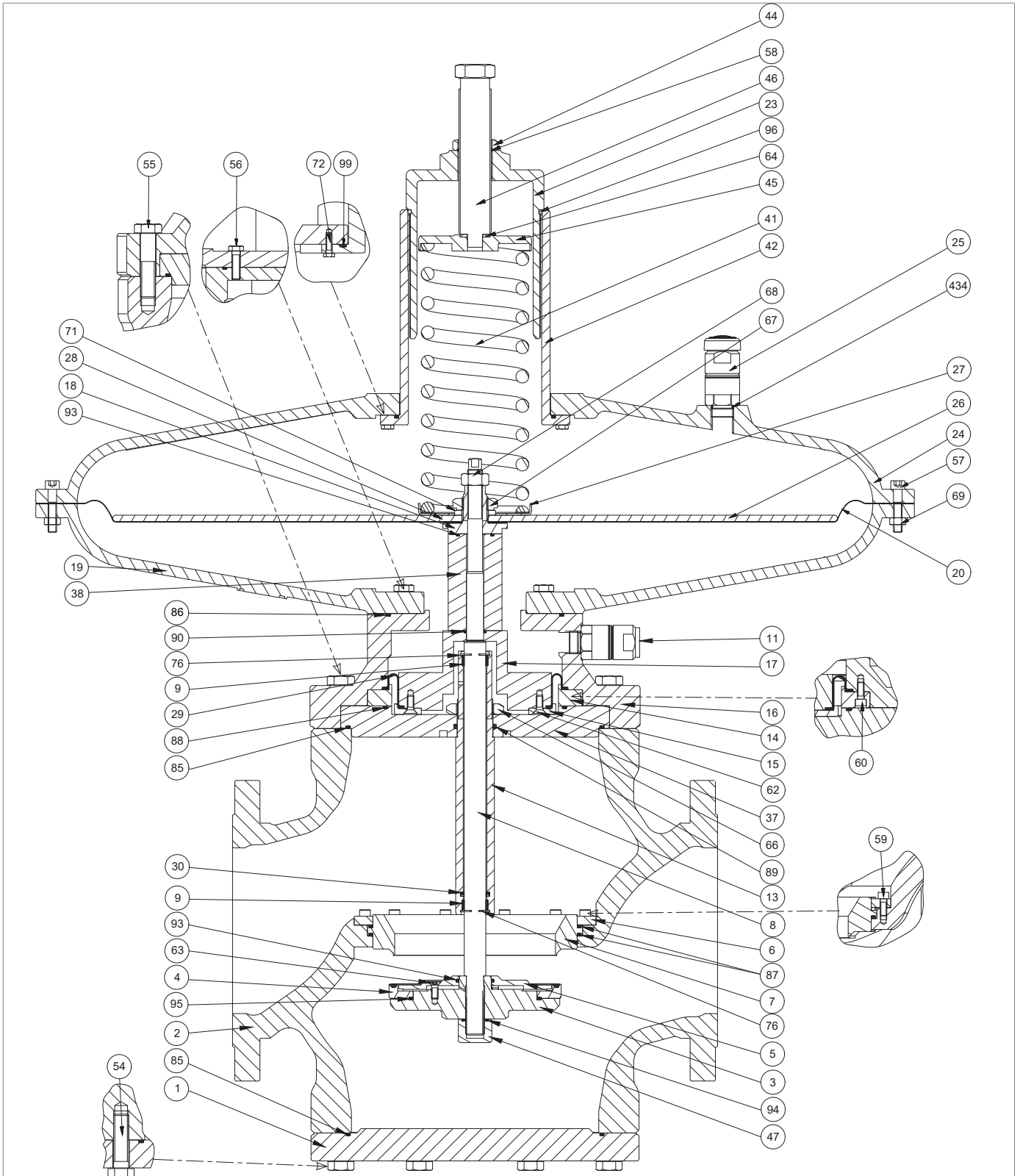



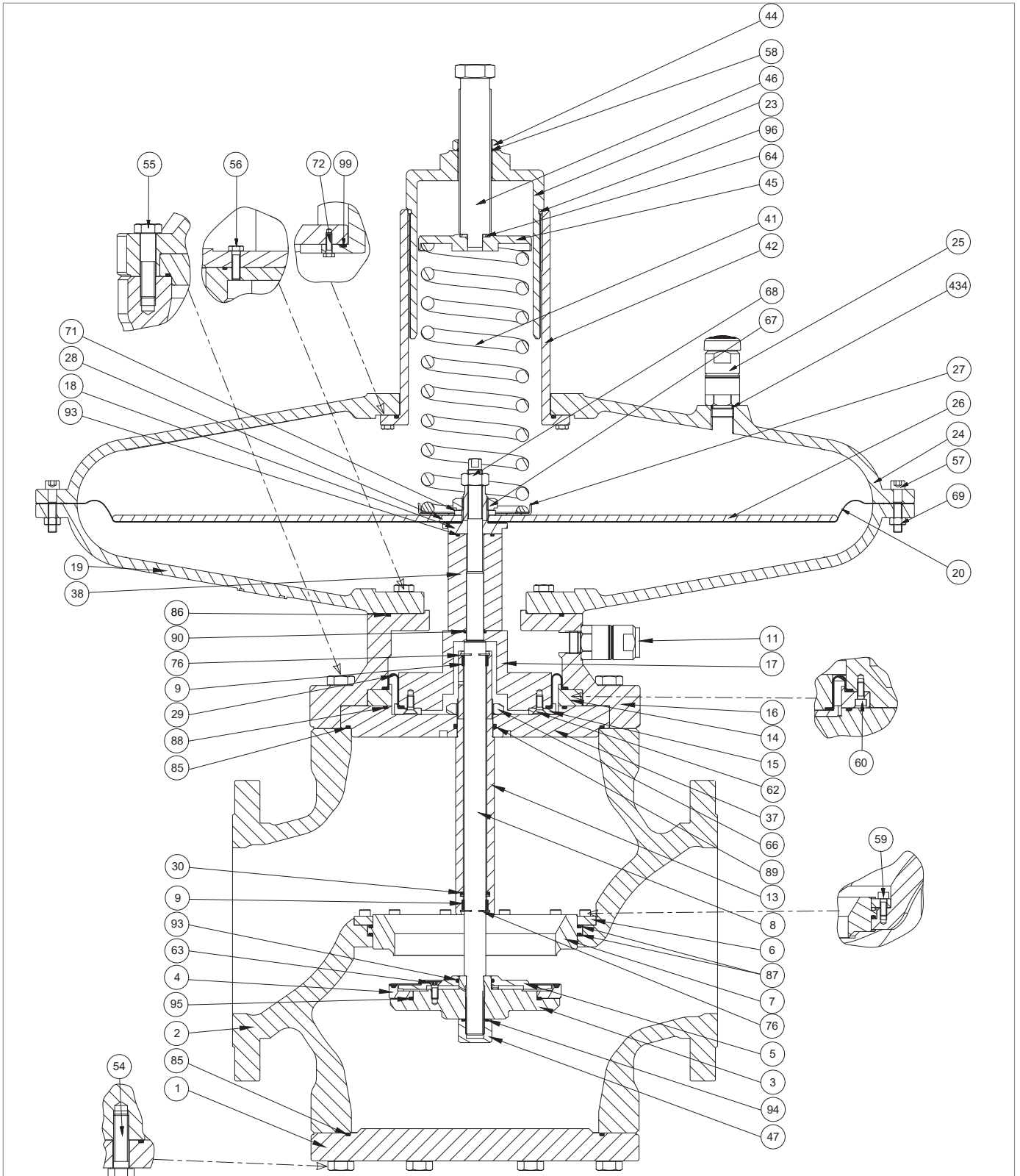

NORVAL Regulator 6'' - 8'' (head 817)

Step	Action
62	Insert the rod guide sleeve (13) together with the lower I/DWR ring (9), the upper I/DWR ring (9), the lower circlip (76), the upper circlip (76) the lip seal (30) into the flange (37).
63	Insert and fix the nut (66) according to the following tightening torques: <ul style="list-style-type: none"> • 6": tab. 9.75 • 8": tab. 9.76
64	Undo and remove the screws (60).
65	Remove the shaft collar (14) from the intermediate body (16).
66	Undo and remove the screws (62) of the spacer (17).
67	Remove the shaft collar (15).
68	Remove the balancing diaphragm (29) and replace it, taking care to lubricate it with synthetic grease. <div style="border: 1px solid black; padding: 5px;">NOTICE!</div> <p>Before inserting the replacement diaphragm, clean the retaining slots with a cleaning solution.</p>
69	Fit the shaft collar (15).
70	Insert and fix the screws (62) according to the following tightening torques: <ul style="list-style-type: none"> • 6": tab. 9.75 • 8": tab. 9.76 <div style="border: 1px solid black; padding: 5px;">NOTICE!</div> <p>Tighten the screws according to the cross diagram in paragraph 9.4.2.2.</p>
71	Fit the shaft collar (14).
72	Position the flange (37), together with the upper and lower I/DWR rings (9), the rod guide sleeve (13), the lip seal (30), the nut (66), the upper and lower circlips (76), the O-rings (88, 89) into the intermediate body (16).
73	Insert and fix the screws (60) according to the following tightening torques: <ul style="list-style-type: none"> • 6": tab. 9.75 • 8": tab. 9.76 <div style="border: 1px solid black; padding: 5px;">NOTICE!</div> <p>Tighten the screws according to the cross diagram in paragraph 9.4.2.2.</p>
74	Fit the flange (37) into the intermediate body (16).
75	Undo and remove the screws (59).
76	Remove the shaft collar (6).
77	Pull out the valve seat (7) from the body (2).
78	Remove the O-rings (87) from the valve seat (7) and replace them, taking care to lubricate them with synthetic grease. <div style="border: 1px solid black; padding: 5px;">NOTICE!</div> <p>Before inserting the replacement O-rings, clean the retaining slots with a cleaning solution.</p>
79	Fit the valve seat (7) in the body (2).
80	Fit the shaft collar (6)



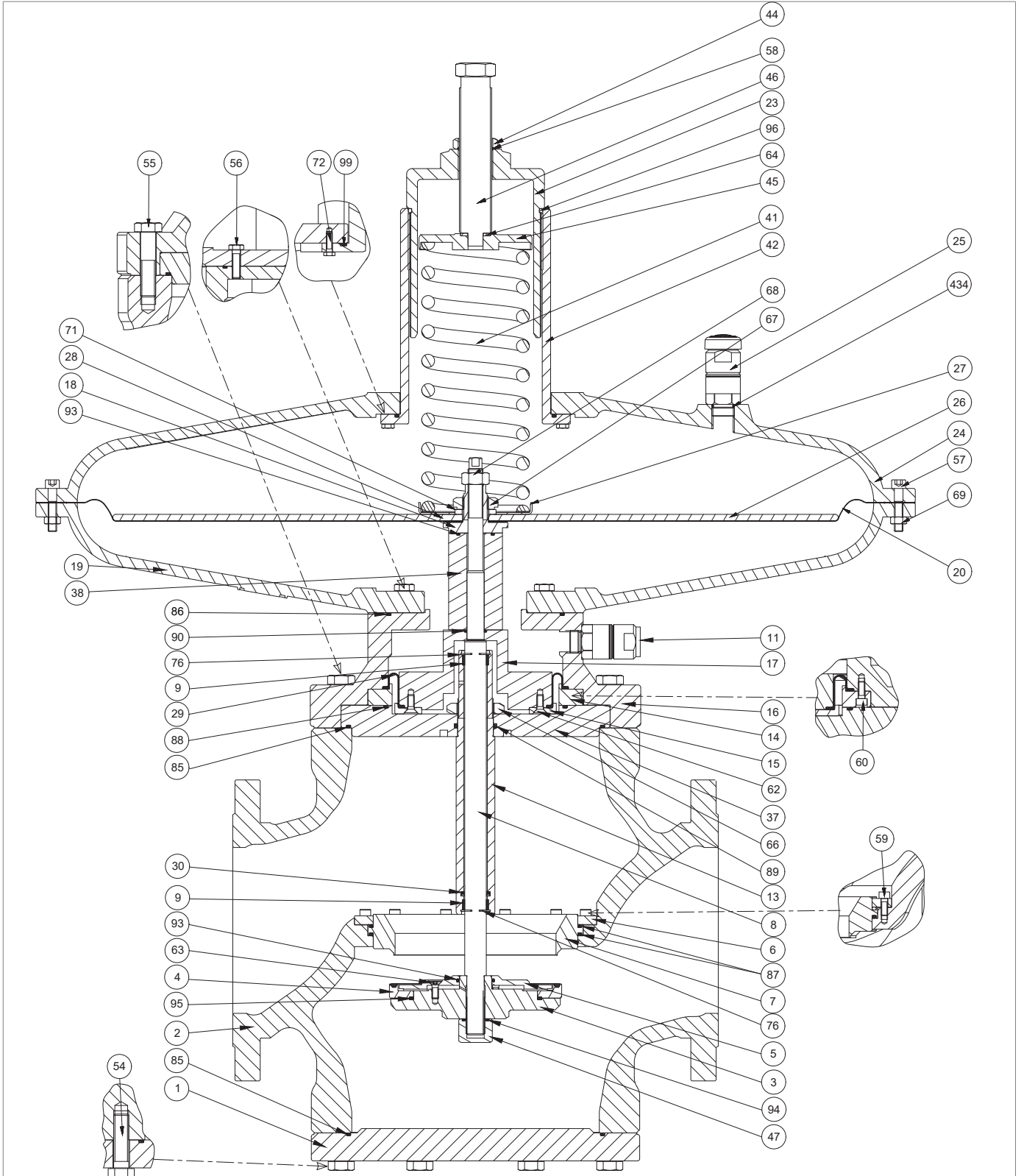

NORVAL Regulator 6'' - 8'' (head 817)

Step	Action
81	<p>Insert and fix the screws (59) according to the following tightening torques:</p> <ul style="list-style-type: none"> 6": tab. 9.75 8": tab. 9.76 <div style="border: 1px solid black; padding: 5px;">  NOTICE! </div> <p>Tighten the screws according to the cross diagram in paragraph 9.4.2.2.</p>
82	Fit the intermediate body assembly (9, 11, 13, 15, 17, 29, 30, 37, 62, 66, 76, 85, 88, 89) into the body (2).
83	<p>Insert and fix the screws (55) according to the following tightening torques:</p> <ul style="list-style-type: none"> 6": tab. 9.75 8": tab. 9.76 <div style="border: 1px solid black; padding: 5px;">  NOTICE! </div> <p>Tighten the screws according to the cross diagram in paragraph 9.4.2.2.</p>
84	<p>Remove the O-ring (90) and replace it, taking care to lubricate it with synthetic grease.</p> <div style="border: 1px solid black; padding: 5px;">  NOTICE! </div> <p>Before inserting the replacement O-ring, clean the retaining slots with a cleaning solution.</p>
85	Position the spacer (38) together with the O-ring (93).
86	<p>Remove the O-ring (86) and replace it, taking care to lubricate it with synthetic grease.</p> <div style="border: 1px solid black; padding: 5px;">  NOTICE! </div> <p>Before inserting the replacement O-ring, clean the retaining slots with a cleaning solution.</p>
87	Fit the bottom cover (19).
88	<p>Insert and fix the screws (56) according to the following tightening torques:</p> <ul style="list-style-type: none"> 6": tab. 9.75 8": tab. 9.76 <div style="border: 1px solid black; padding: 5px;">  NOTICE! </div> <p>Tighten the screws according to the cross diagram in paragraph 9.4.2.2.</p>
89	<p>Fit the diaphragm assembly (18, 20, 26, 27, 67).</p> <div style="border: 1px solid black; padding: 5px;">  NOTICE! </div> <p>Centre the diaphragm support hole (18) with the hole of the spacer (38).</p>
90	Insert the rod (8) into the rod guide sleeve (13) from the bottom upwards.
91	<p>Insert the lock nut (68).</p> <div style="border: 1px solid black; padding: 5px;">  NOTICE! </div> <p>Align the housing of the rod fixing spanner (8) and the housing of the diaphragm support fixing spanner (18).</p>
92	Align the hole of the diaphragm (20) with the bottom cover holes (19).
93	<p>Insert the locking nut (68) according to the following tightening torques:</p> <ul style="list-style-type: none"> 6": tab. 9.75 8": tab. 9.76 <div style="border: 1px solid black; padding: 5px;">  NOTICE! </div> <ul style="list-style-type: none"> During this phase, keep the rod (8) and the diaphragm support (18) still Tighten the screws according to the cross diagram in paragraph 9.4.2.2.



NORVAL Regulator 6'' - 8'' (head 817)

Step	Action
94	Fit the top cover (24).
95	Insert and fix the screws (57) together with the nuts (69) according to the following tightening torques: <ul style="list-style-type: none"> • 6": tab. 9.75 • 8": tab. 9.76 <div style="border: 1px solid blue; padding: 5px; margin-top: 5px;">  NOTICE! Tighten the screws according to the cross diagram in paragraph 9.4.2.2. </div>
96	Screw the adjustment assembly (3, 4, 95, 63, 93, 5) into the rod (8) clockwise.
97	Insert and fix the nut (47) together with the O-ring (94) according to the following tightening torques: <ul style="list-style-type: none"> • 6": tab. 9.75 • 8": tab. 9.76
98	Fit the lower flange (1).
99	Insert and fix the screws (54) according to the following tightening torques: <ul style="list-style-type: none"> • 6": tab. 9.75 • 8": tab. 9.76 <div style="border: 1px solid blue; padding: 5px; margin-top: 5px;">  NOTICE! Tighten the screws according to the cross diagram in paragraph 9.4.2.2. </div>
100	Insert the regulation spring (41).
101	Insert the spring guide (45) together with the disc (64).
102	Insert and fix the cap (23), together with the O-rings (58, 96), the adjustment screw (46) and the lock nut (44).

 **WARNING!**

Ensure that all parts have been fitted correctly.

9.4.5 - MAINTENANCE OF NORVAL REGULATOR WITH MONITOR FUNCTION WITH ER DEVICE

9.4.5.1 - NORVAL REGULATOR WITH MONITOR + ER DEVICE FUNCTION 1" - 3"

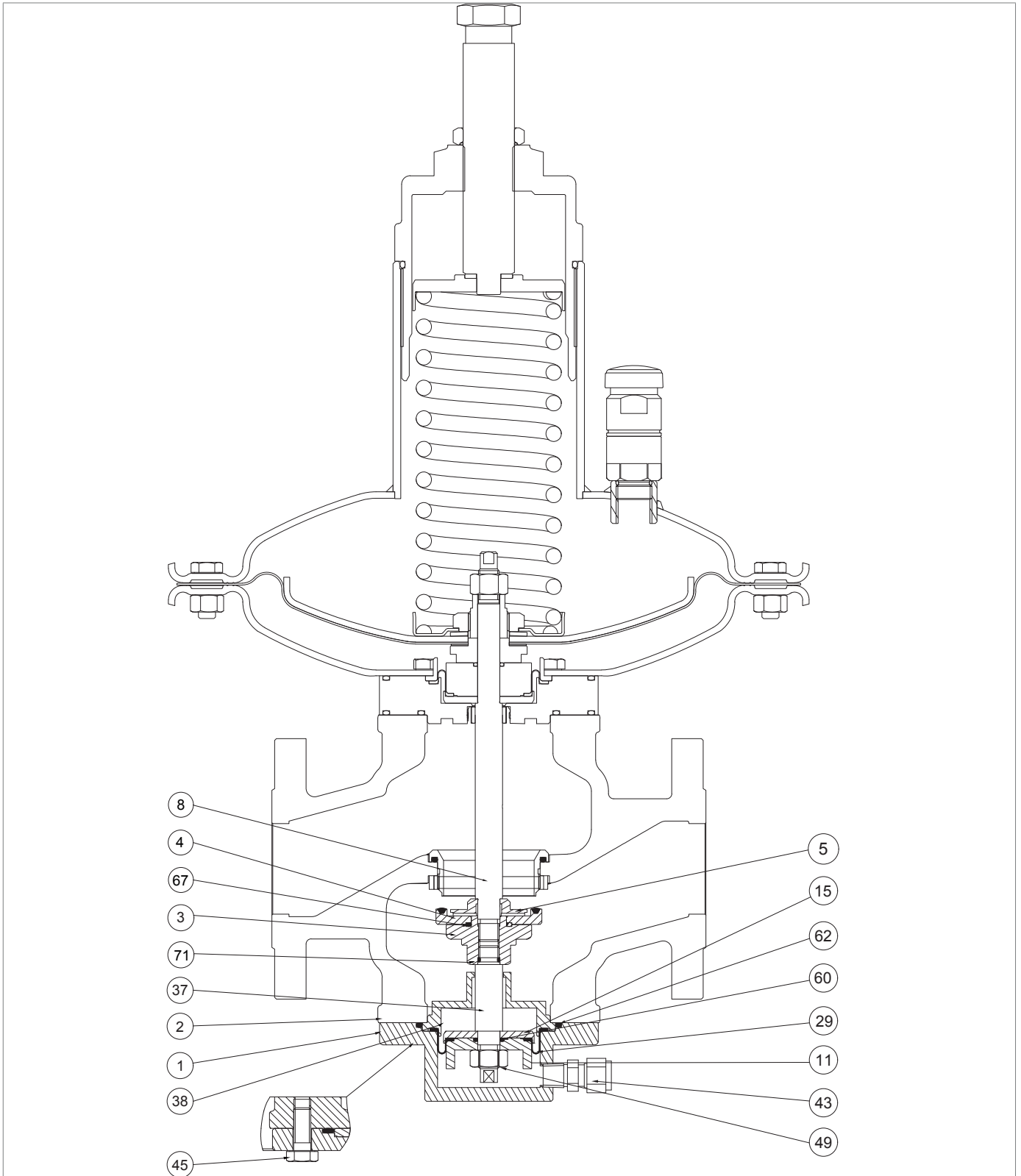
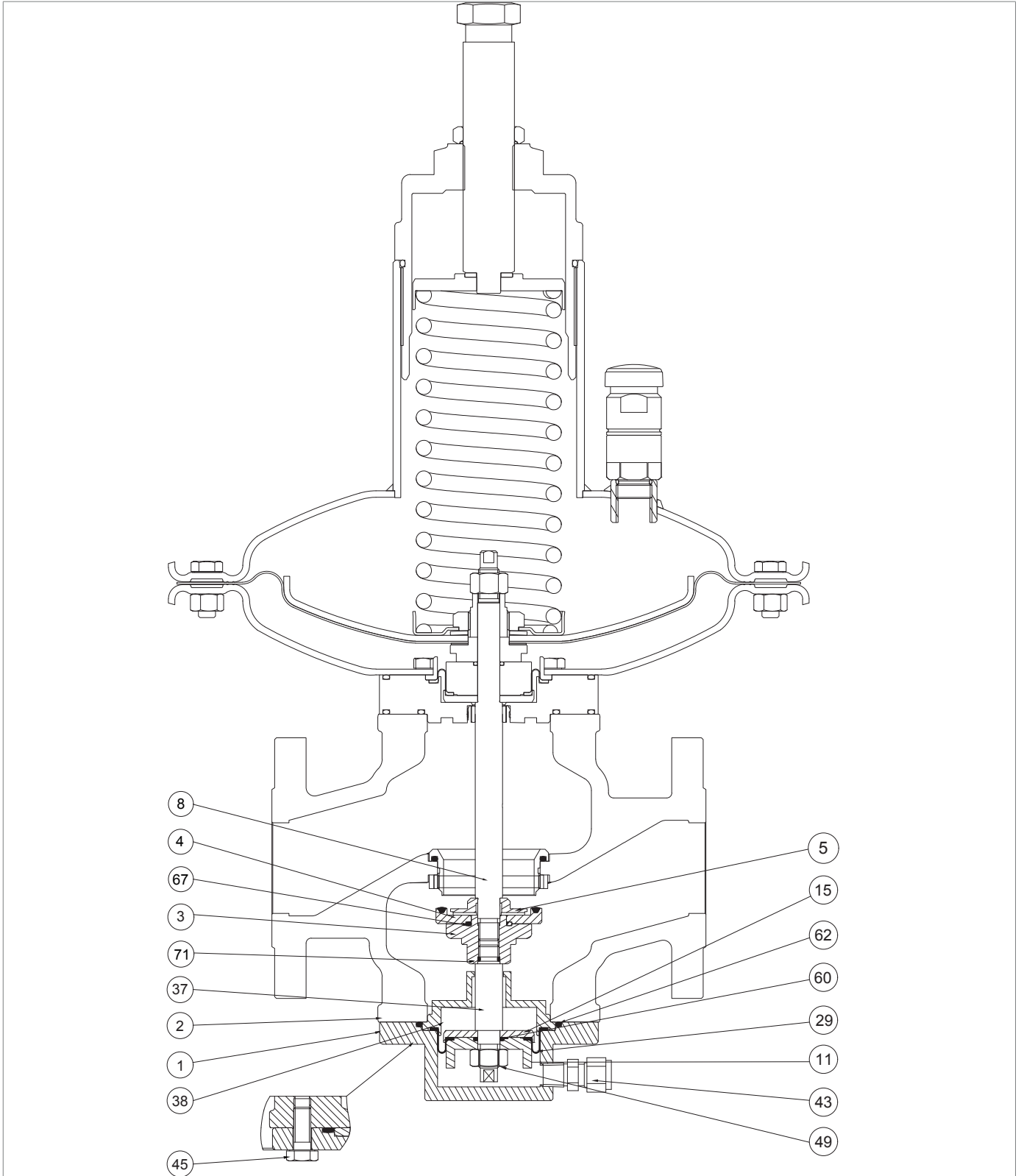



Fig. 9.49. NORVAL Regulator-monitor + ER 1" - 3"

Step	Action
1	Loosen the nut (49) together with the assembly (3, 4, 5, 11, 15, 29, 37, 38, 60, 95, 94) from the body (2).
2	Remove the reinforced gasket protection disc (5).
3	Remove the reinforced gasket (4).
4	Remove the O-ring (67) and replace it, taking care to lubricate it with synthetic grease. <div style="border: 1px solid blue; padding: 2px;">! NOTICE! Before inserting the replacement O-ring, clean the retaining slots with a cleaning solution.</div>
5	Unscrew the rod extension of the ER device (37). <div style="border: 1px solid blue; padding: 2px;">! NOTICE! During this phase, keep the locking nut (3) still.</div>
6	Remove the rod extension of the ER device (37), together with the O-ring (94), the monitor flange (38), the clamping disc (15), the balancing diaphragm (29), the O-ring (60), the spacer (11) and the locking nut(49).
7	Remove the O-ring (94) and replace it, taking care to lubricate it with synthetic grease. <div style="border: 1px solid blue; padding: 2px;">! NOTICE! Before inserting the replacement O-ring, clean the retaining slots with a cleaning solution.</div>
8	Remove the monitor flange (38).
9	Unscrew and remove the locking nut (49). <div style="border: 1px solid blue; padding: 2px;">! NOTICE! During this phase, keep the rod extension of the ER device (37) still.</div>
10	Remove the spacer (11).
11	Remove the balancing diaphragm (29) and replace it, taking care to lubricate it with synthetic grease. <div style="border: 1px solid blue; padding: 2px;">! NOTICE! Before inserting the replacement diaphragm, clean the retaining slots with a cleaning solution.</div>
12	Remove the O-ring (60) and replace it, taking care to lubricate it with synthetic grease. <div style="border: 1px solid blue; padding: 2px;">! NOTICE! Before inserting the replacement O-ring, clean the retaining slots with a cleaning solution.</div>
13	Position the spacer (11).
14	Insert and fasten the locking nut (49) 1": tab. 9.77 <ul style="list-style-type: none"> • 1" ½: tab. 9.78 • 2": tab. 9.79 • 2" ½: tab. 9.80 • 3": tab. 9.81 <div style="border: 1px solid blue; padding: 2px;">! NOTICE! During this phase, keep the rod extension of the ER device (37) still.</div>
15	Fit the monitor flange (38).



NORVAL Regulator-monitor + ER 1" - 3"

Step	Action
16	Insert the rod extension of the ER device (37) into the locking nut (3), according to the following tightening torques: <ul style="list-style-type: none"> • 1": tab. 9.77 • 1" ½: tab. 9.78 • 2": tab. 9.79 • 2" ½: tab. 9.80 • 3": tab. 9.81
17	Insert and fasten the locking nut (3). <div style="border: 1px solid blue; padding: 5px; margin-top: 5px;">  NOTICE! During this phase, keep the locking nut (49) still. </div>
18	Remove the O-ring (95) and replace it, taking care to lubricate it with synthetic grease. <div style="border: 1px solid blue; padding: 5px; margin-top: 5px;">  NOTICE! Before inserting the replacement O-ring, clean the retaining slots with a cleaning solution. </div>
19	Replace the reinforced gasket (4).
20	Fit the reinforced gasket protection disc (5).
21	Fit and fix (3, 4, 5, 11, 15, 29, 37, 38, 60, 95, 94) in the body (2).
22	Fix the rod extension of the ER device (37) and the locking nut (3), the O-ring (94) to the rod (8) with the locking nut (68).

Tab. 9.104.

 **WARNING!**

After maintenance of the regulator with ER device, go back to:

- 1" - 2", head 375TR: par. 9.4.4.1, step 13
- 1" - 2", head 375: par. 9.4.4.2, step 12
- 1" - 2", head 495: par. 9.4.4.3, step 12

- 2 ½ - 3, head 375TR: par. 9.4.4.4, step 13
- 2 ½ - 3, head 375: par. 9.4.4.5, step 12
- 2 ½ - 3, head 495: par. 9.4.4.6, step 13
- 2 ½ - 3, head 630: par. 9.4.4.7, step 12

9.4.5.2 - NORVAL REGULATOR WITH MONITOR + ER DEVICE FUNCTION 4"

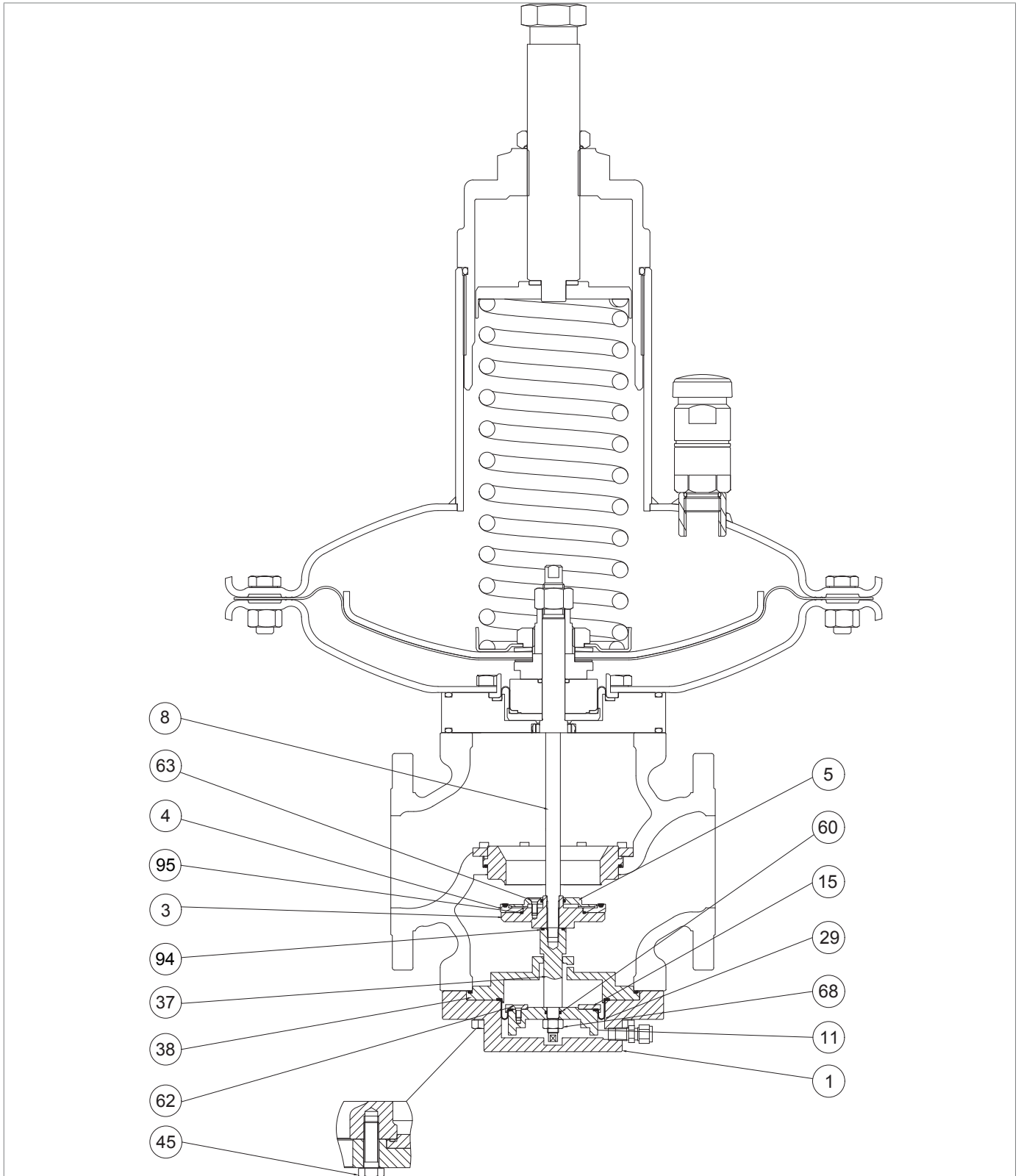
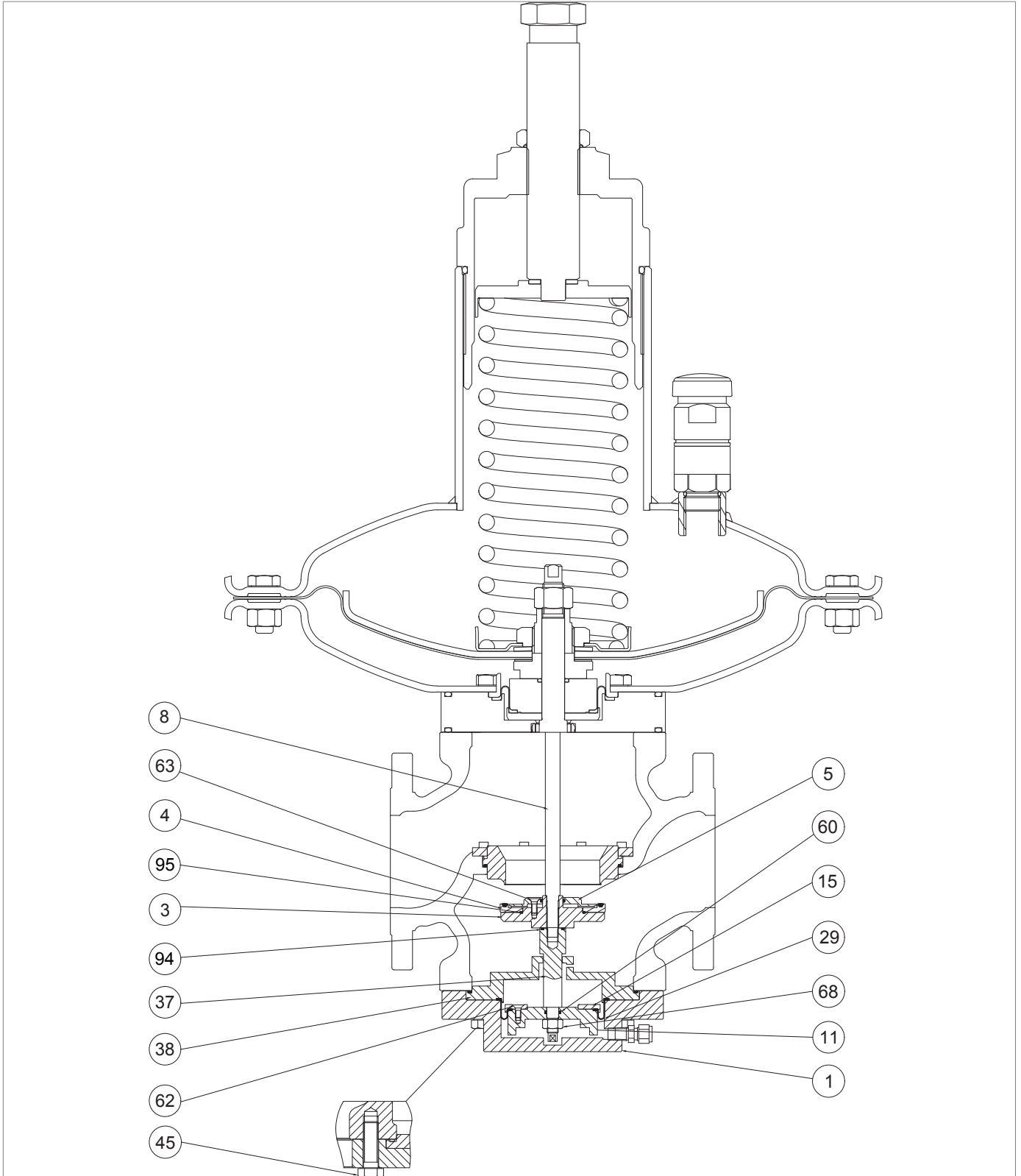

Fig. 9.50. NORVAL Regulator-monitor + ER 4"

Step	Action
1	Loosen the nut (68) together with the assembly (3, 4, 5, 11, 15, 29, 37, 38, 60, 62, 94) from the rod (8).
2	Unscrew and remove the reinforced gasket support (3), the O-rings (93, 95), the screw (63), the reinforced gasket (4), the reinforced gasket protection disk (5) from the rod (8).
3	Undo and remove the screws (63).
4	Remove the reinforced gasket protection disc (5).
5	Remove the O-ring (93) from the reinforced gasket projection disc (5) and replace it, taking care to lubricate it with synthetic grease. <div style="border: 1px solid black; padding: 5px;">NOTICE! Before inserting the replacement O-ring, clean the retaining slots with a cleaning solution.</div>
6	Remove and replace the reinforced gasket (4) together with the O-ring (94).
7	Remove the O-ring (95) and replace it, taking care to lubricate it with synthetic grease. <div style="border: 1px solid black; padding: 5px;">NOTICE! Before inserting the replacement O-ring, clean the retaining slots with a cleaning solution.</div>
8	Fit the reinforced gasket (4) together with the O-ring (94).
9	Fit the reinforced gasket protection disc (5).
10	Insert and fix the screws (63).
11	Insert and fix the reinforced gasket support (3), the O-rings (93, 95), the screw (63), the reinforced gasket (4), the reinforced gasket protection disk (5) in the rod (8).
12	Unscrew and remove the locking nut (68). <div style="border: 1px solid black; padding: 5px;">NOTICE! During this phase, keep the rod extension of the ER device (37) still.</div>
13	Pull out the rod extension of the ER device (37) from the monitor flange (38).
14	Remove the O-ring (94) and replace it, taking care to lubricate it with synthetic grease. <div style="border: 1px solid black; padding: 5px;">NOTICE! Before inserting the replacement O-ring, clean the retaining slots with a cleaning solution.</div>
15	Remove the monitor flange (38).
16	Undo and remove the screws (62).
17	Remove the clamping disc (15).
18	Remove the balancing diaphragm (29) and replace it, taking care to lubricate it with synthetic grease. <div style="border: 1px solid black; padding: 5px;">NOTICE! Before inserting the replacement diaphragm, clean the retaining slots with a cleaning solution.</div>
19	Remove the O-ring (60) from the spacer (11) and replace it, taking care to lubricate it with synthetic grease. <div style="border: 1px solid black; padding: 5px;">NOTICE! Before inserting the replacement O-ring, clean the retaining slots with a cleaning solution.</div>



NORVAL Regulator-monitor + ER 4"

Step	Action
20	Fit the diaphragm (29).
21	Fit the clamping disc (15).
22	<p>Insert and fix the screws (62) according to the following tightening torques:</p> <ul style="list-style-type: none"> • 1": tab. 9.77 • 1" ½: tab. 9.78 • 2": tab. 9.79 • 2" ½: tab. 9.80 • 3": tab. 9.81 <div style="border: 1px solid blue; padding: 5px;"> <p>! NOTICE! Tighten the screws according to the cross diagram in paragraph 9.4.2.2.</p> </div>
23	Insert the rod extension of the ER device (37) into the monitor flange (38).
24	<p>Insert and fix the nut (68) according to the following tightening torques:</p> <ul style="list-style-type: none"> • 1": tab. 9.77 • 1" ½: tab. 9.78 • 2": tab. 9.79 • 2" ½: tab. 9.80 • 3": tab. 9.81 <div style="border: 1px solid blue; padding: 5px;"> <p>! NOTICE! During this phase, keep the rod extension of the ER device (37) still.</p> </div>
25	<p>Remove the O-ring (85) and replace it, taking care to lubricate it with synthetic grease.</p> <div style="border: 1px solid blue; padding: 5px;"> <p>! NOTICE! Before inserting the replacement O-ring, clean the retaining slots with a cleaning solution.</p> </div>
26	Position and secure the assembly (3, 4, 5, 11, 15, 29, 37, 38, 60, 62, 94) in the rod (8).
27	Fit the lower flange (1).
28	Insert and fix the screws (54).

Tab. 9.105.

! WARNING!

After maintenance of the regulator with ER device, go back to:

- 4", head 375TR: par. 9.4.4.8, step 13
- 4", head 375: par. 9.4.4.9, step 13
- 4", head 495: par. 9.4.4.10, step 12
- 4", head 630: par. 9.4.4.11, step 12

9.4.5.3 - NORVAL REGULATOR WITH MONITOR + ER DEVICE FUNCTION 6" - 8"

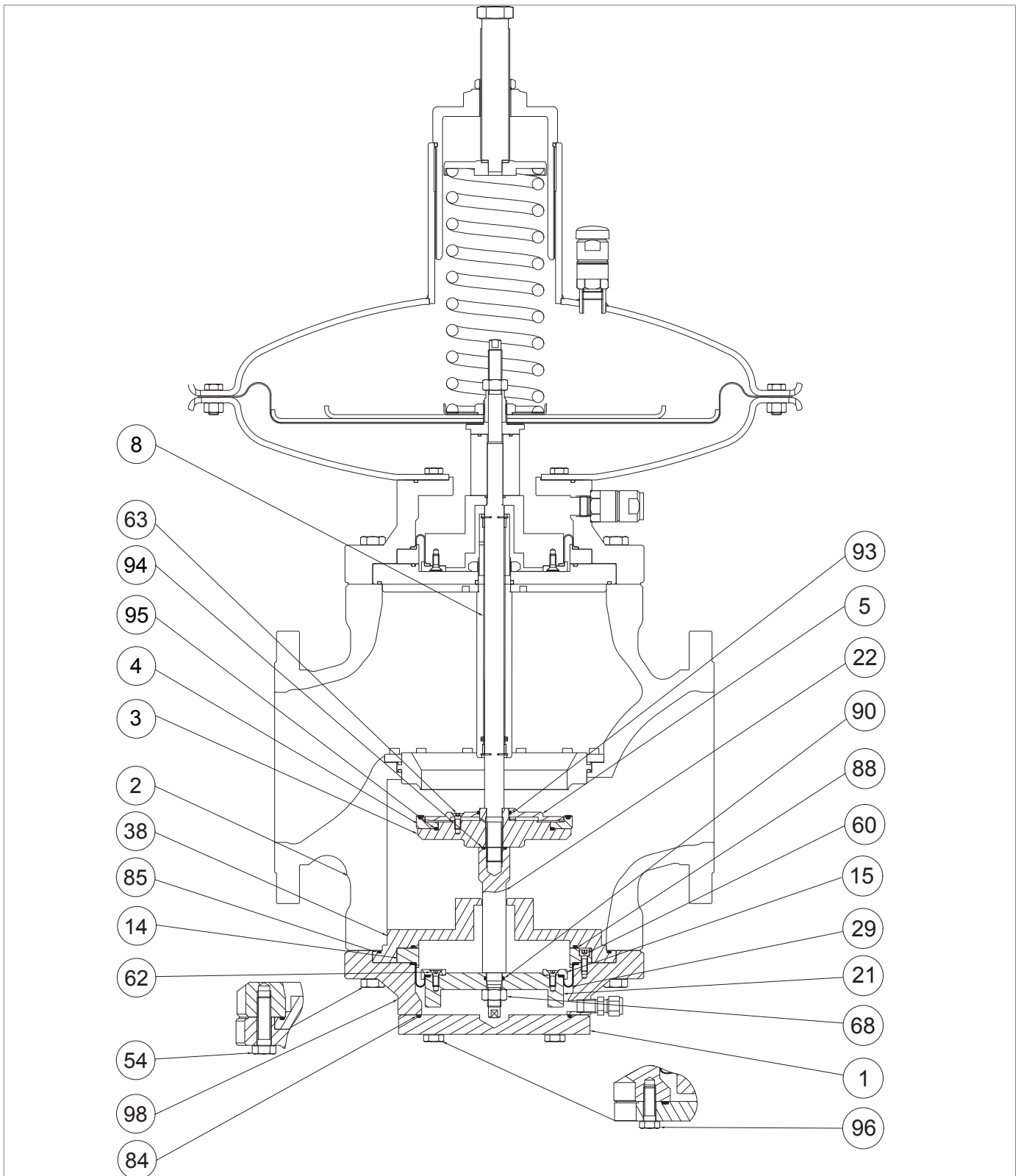
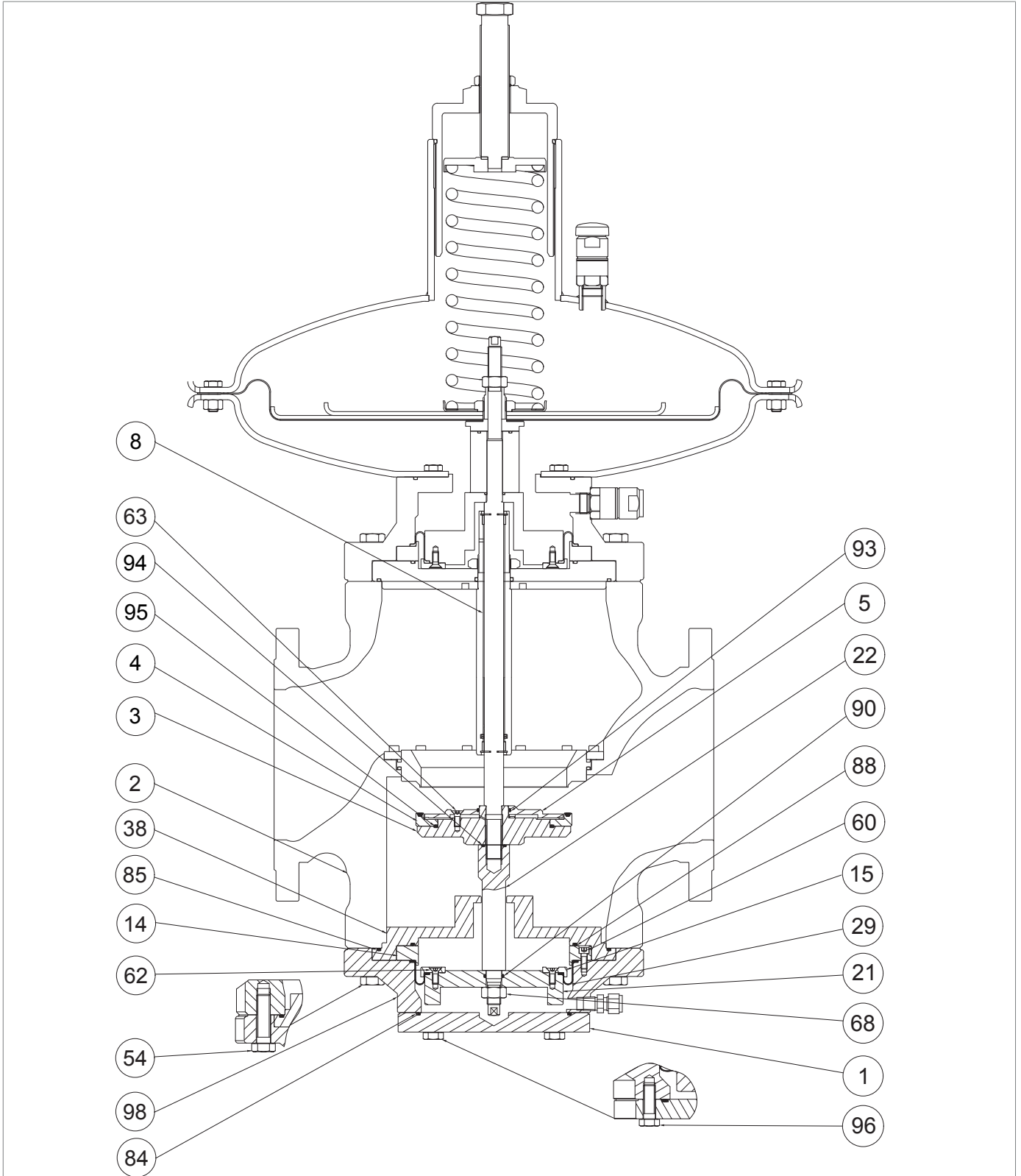







Fig. 9.51. NORVAL Regulator-monitor + ER 6" - 8"

Step	Action
1	Undo and remove the screws (96).
2	Remove the bottom flange (1), taking care to support it.
3	Remove the O-ring (84) and replace it, taking care to lubricate it with synthetic grease. ! NOTICE! Before inserting the replacement O-ring, clean the retaining slots with a cleaning solution.
4	Unscrew and remove the nut (68) from the monitor rod extension (22).
5	Undo and remove the screws (54). ! NOTICE! During this phase, sustain the flange (98).
6	Remove the flange (98) together with the spacer (21), the O-rings (90, 88, 85), screws (62, 60), the clamping disc (15), the monitor flange (38), and the shaft collar (14).
7	Remove the monitor flange (38).
8	Remove and replace the O-rings (85, 88), taking care to lubricate them with synthetic grease. ! NOTICE! Before inserting the replacement O-rings, clean the retaining slots with a cleaning solution.
9	Undo and remove the screws (60) from the shaft collar (14).
10	Remove the shaft collar (14).
11	Undo and remove the screws (62).
12	Remove the clamping disc (15).
13	Remove the balancing diaphragm (29) and replace it, taking care to lubricate it with synthetic grease. ! NOTICE! Before inserting the replacement diaphragm, clean the retaining slots with a cleaning solution.
14	Remove the O-ring (90) from the spacer (21) and replace it, taking care to lubricate it with synthetic grease. ! NOTICE! Before inserting the replacement O-ring, clean the retaining slots with a cleaning solution.
15	Fit the diaphragm (29).
16	Fit the clamping disc (15).
17	Insert and fix the screws (62) according to the following tightening torques: <ul style="list-style-type: none"> • 6: tab. 9.83 • 8: tab. 9.84 ! NOTICE! Tighten the screws according to the cross diagram in paragraph 9.4.2.2.
18	Fit the shaft collar (14).



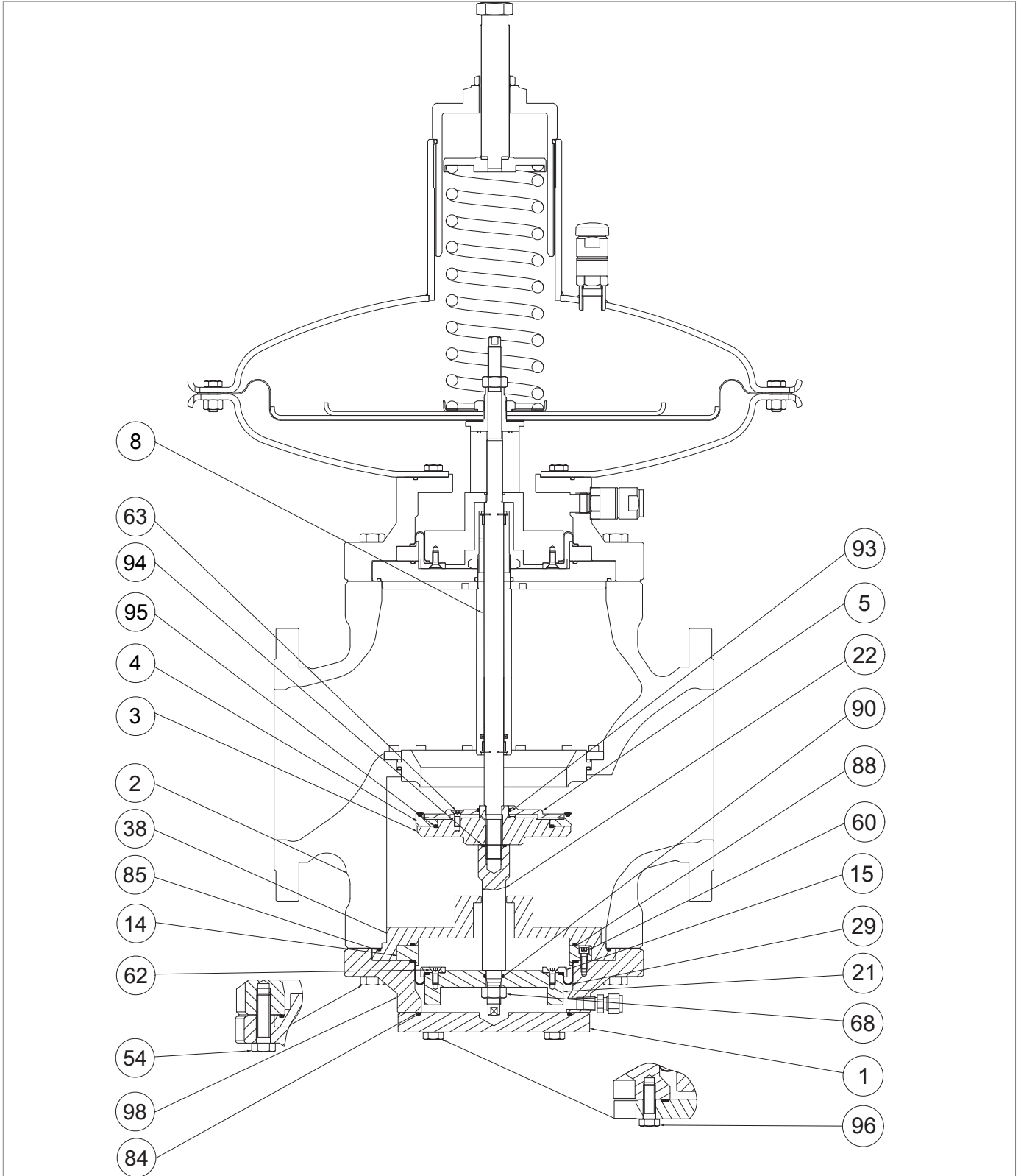

NORVAL Regulator-monitor + ER 6'' - 8''

Step	Action
19	Insert and fix the screws (60) according to the following tightening torques: <ul style="list-style-type: none"> • 6: tab. 9.83 • 8: tab. 9.84 <div style="border: 1px solid black; padding: 5px;">  NOTICE! Tighten the screws according to the cross diagram in paragraph 9.4.2.2. </div>
20	Unscrew and remove the monitor rod extension (22) from the rod (8).
21	Remove the O-ring (94) and replace it, taking care to lubricate it with synthetic grease. <div style="border: 1px solid black; padding: 5px;">  NOTICE! Before inserting the replacement O-ring, clean the retaining slots with a cleaning solution. </div>
22	Unscrew and remove the reinforced gasket support (3), the O-rings (93, 95), the screws (63), the reinforced gasket (4), the reinforced gasket protection disk (5) from the rod (8).
23	Undo and remove the screws (63).
24	Remove the reinforced gasket protection disc (5).
25	Remove the O-ring (93) from the reinforced gasket projection disc (5) and replace it, taking care to lubricate it with synthetic grease. <div style="border: 1px solid black; padding: 5px;">  NOTICE! Before inserting the replacement O-ring, clean the retaining slots with a cleaning solution. </div>
26	Remove and replace the reinforced gasket (4).
27	Remove the O-ring (95) and replace it, taking care to lubricate it with synthetic grease. <div style="border: 1px solid black; padding: 5px;">  NOTICE! Before inserting the replacement O-ring, clean the retaining slots with a cleaning solution. </div>
28	Fit the reinforced gasket (4).
29	Fit the reinforced gasket protection disc (5).
30	Insert and fix the screws (63).
31	Insert and fix the reinforced gasket support (3), the O-rings (93, 95), the screws (63), the reinforced gasket (4), the reinforced gasket protection disk (5) in the rod (8).
32	<div style="background-color: yellow; padding: 5px;">  ATTENTION! </div> Go back to maintenance of NORVAL regulator 6" - 8" <ul style="list-style-type: none"> • head 495: par. 9.4.4.12, step 24 • head 630: par. 9.4.4.13, step 23 • head 658: par. 9.4.4.14, step 24 • head 817: par. 9.4.4.15, step 24
33	Insert and fix the monitor rod extension (22) to the rod (8) according to the following tightening torques: <ul style="list-style-type: none"> • 6: tab. 9.83 • 8: tab. 9.84
34	Fit the monitor flange (38).



NORVAL Regulator-monitor + ER 6'' - 8''

Step	Action
35	Fit the flange (98) together with the spacer (21), the O-rings (90, 88, 85), the screws (62, 60), the clamping disc (15), the monitor flange (38), and the shaft collar (14)
36	Insert and fix the screws (54) according to the following tightening torques: <ul style="list-style-type: none"> • 6: tab. 9.83 • 8: tab. 9.84 <div style="border: 1px solid blue; padding: 5px;">  NOTICE! Tighten the screws according to the cross diagram in paragraph 9.4.2.2. </div>
37	Insert and fix the nut (68) according to the following tightening torques: <ul style="list-style-type: none"> • 6: tab. 9.83 • 8: tab. 9.84 <div style="border: 1px solid blue; padding: 5px;">  NOTICE! During this phase, keep the rod extension of the ER device (22) still. </div>
38	Fit the lower flange (1), sustaining it carefully.
39	Insert and fix the screws (96) according to the following tightening torques: <ul style="list-style-type: none"> • 6: tab. 9.83 • 8: tab. 9.84 <div style="border: 1px solid blue; padding: 5px;">  NOTICE! Tighten the screws according to the cross diagram in paragraph 9.4.2.2. </div>

Tab. 9.106.
 **WARNING!**

After maintenance of the NORVAL regulator with monitor function with ER device, go back to:

- 6" - 8", head 495: par. 9.4.4.12, step 96
- 6" - 8", head 630: par. 9.4.4.13, step 96
- 6" - 8", head 658: par. 9.4.4.14, step 103
- 6" - 8", head 817: par. 9.4.4.15, step 100

9.4.6 - MAINTENANCE OF NORVAL REGULATOR WITH SN SLAM-SHUT VALVE

9.4.6.1 - NORVAL REGULATOR + SLAM-SHUT VALVE SN 1" - 3"

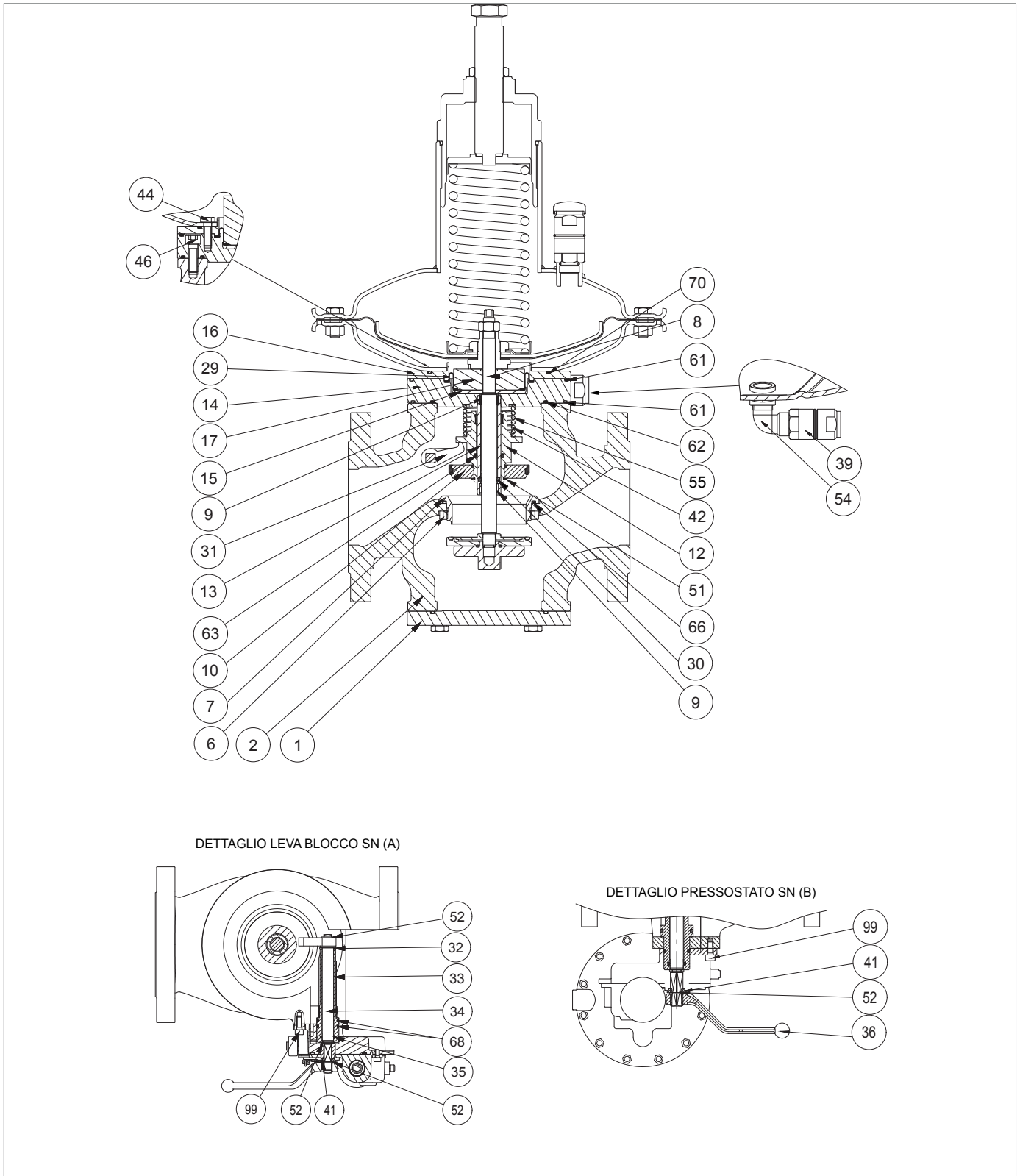





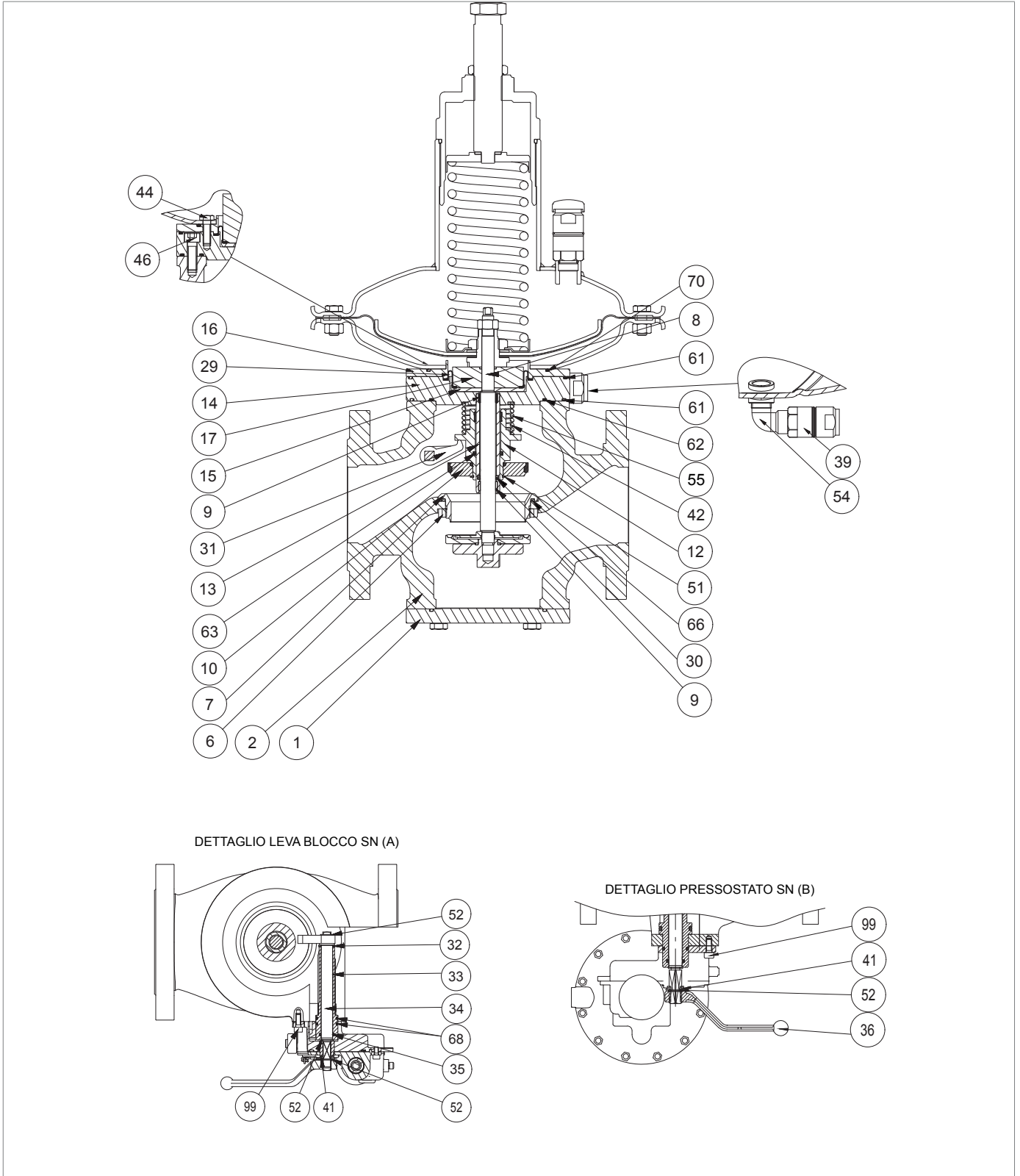



Fig. 9.52. NORVAL + SN 1" - 3"

Step	Action
1	Remove the spring (42).
2	Remove the plug support (12) together with the I/DWR ring (55), the O-ring (63), the plug (10) and the shaft collar (51).
3	Remove the shaft collar (51).
4	Remove and replace the plug (10).
5	Fit the shaft collar (51).
6	Remove the O-ring (63) and replace it, taking care to lubricate it with synthetic grease.  NOTICE! Before inserting the replacement O-ring, clean the retaining slots with a cleaning solution.
7	Remove the I/DWR ring (55) and replace it, taking care to lubricate it with synthetic grease.  NOTICE! Before inserting the replacement O-ring, clean the retaining slots with a cleaning solution.
8	Undo and remove the locking ring nut (6).
9	Remove the coupling lever (36).
10	Remove the outer Seeger ring (52).
11	Remove the position indicator (41).
12	Remove the inner Seeger ring (52).
13	Remove the screws (99).
14	Pull out the SN pressure switch (detail B) from the bush (33).
15	Pull out the bush (33), together with the O-rings (35, 68) from the body (1).
16	Remove the O-ring (35) and replace it, taking care to lubricate it with synthetic grease.  NOTICE! Before inserting the replacement O-ring, clean the retaining slots with a cleaning solution.
17	Remove and replace the O-rings (68), taking care to lubricate them with synthetic grease.  NOTICE! Before inserting the replacement O-rings, clean the retaining slots with a cleaning solution.
18	Position the bush (33), together with the O-rings (35, 68) in the body (1).
19	Insert the inner Seeger ring (52).
20	Position the SN pressure switch (detail B) in the bush (33)
21	Insert and fix the screws (99) according to the following tightening torques: <ul style="list-style-type: none"> • 1 - 3: tab. 9.85  NOTICE! Tighten the screws according to the cross diagram in paragraph 9.4.2.2.



NORVAL + SN 1" - 3"

Step	Action
22	Fit the position indicator (41).
23	Fit the outer Seeger ring (52).
24	Fit the coupling lever (36).
25	Pull out the valve seat (7) together with the O-ring (66) from the body (2) from the bottom upwards.
26	Replace the O-ring (66) and lubricate it with synthetic grease.  NOTICE! Before inserting the replacement O-ring, clean the retaining slots with a cleaning solution.
27	Insert the valve seat (7) together with the O-ring (66) into the body (2) from the top downwards.
28	Insert and fasten the locking ring nut (6).
29	Position the bush (12) together with the I/DWR ring (55), the O-ring (63), the plug (10) and the shaft collar (51).  NOTICE! During this phase, hold the coupling lever (36) between the bush (12) and the plug (10).
30	Fit the spring (42).
31	Insert the flange (14) into the body (2) together with the rod guide sleeve (13).

Tab. 9.107.

 **WARNING!**

After maintenance of the regulator with SN slam-shut valve, go back to:

- 1" - 2", head 375TR: par. 9.4.4.1, step 43
- 1" - 2", head 375: par. 9.4.4.2, step 40
- 1" - 2", head 495: par. 9.4.4.3, step 42

- 2 ½ - 3, head 375TR: par. 9.4.4.4, step 44
- 2 ½ - 3, head 375: par. 9.4.4.5, step 42
- 2 ½ - 3, head 495: par. 9.4.4.6, step 42
- 2 ½ - 3, head 630: par. 9.4.4.7, step 42

9.4.6.2 - NORVAL REGULATOR + SLAM-SHUT VALVE SN 4"

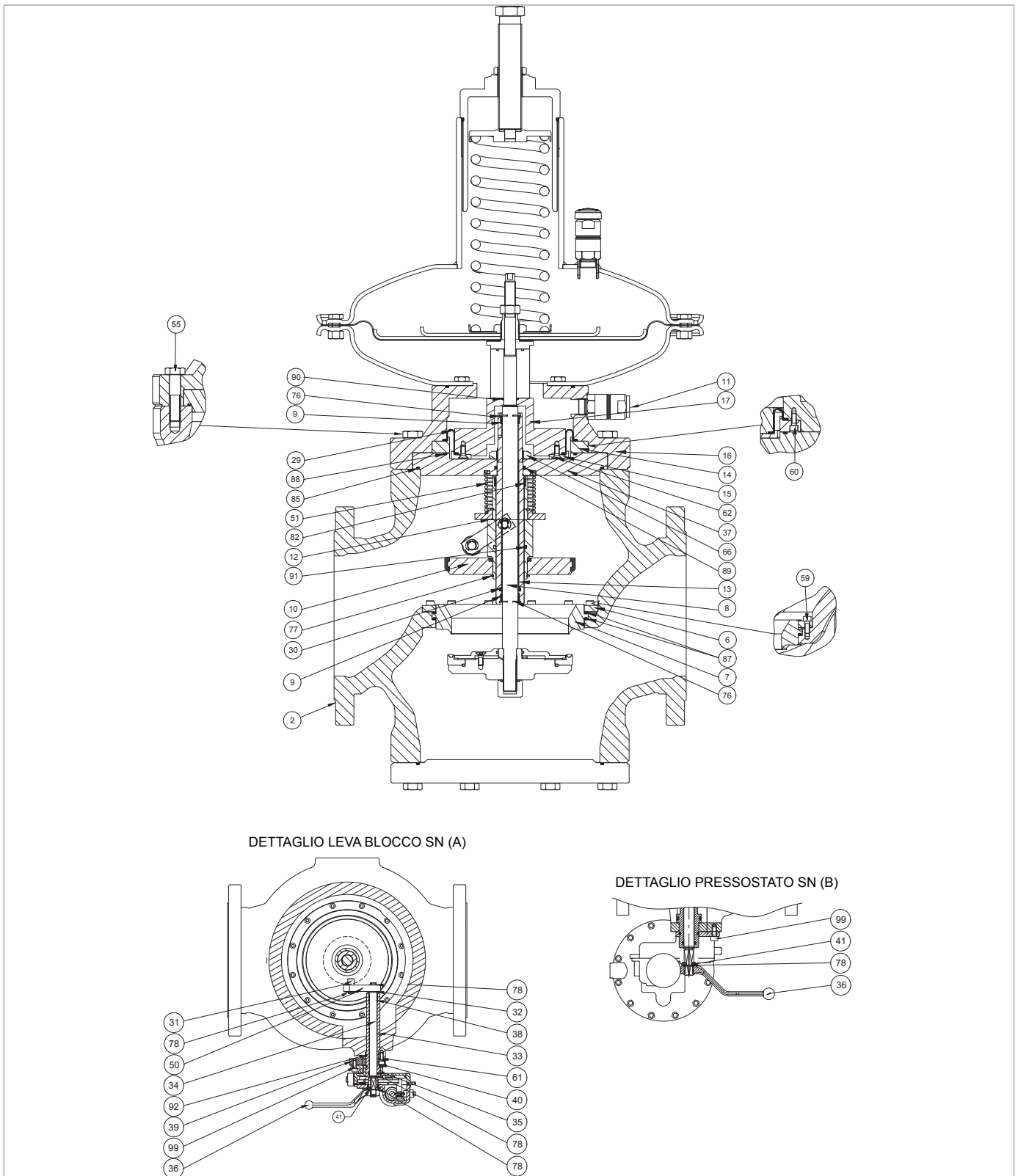
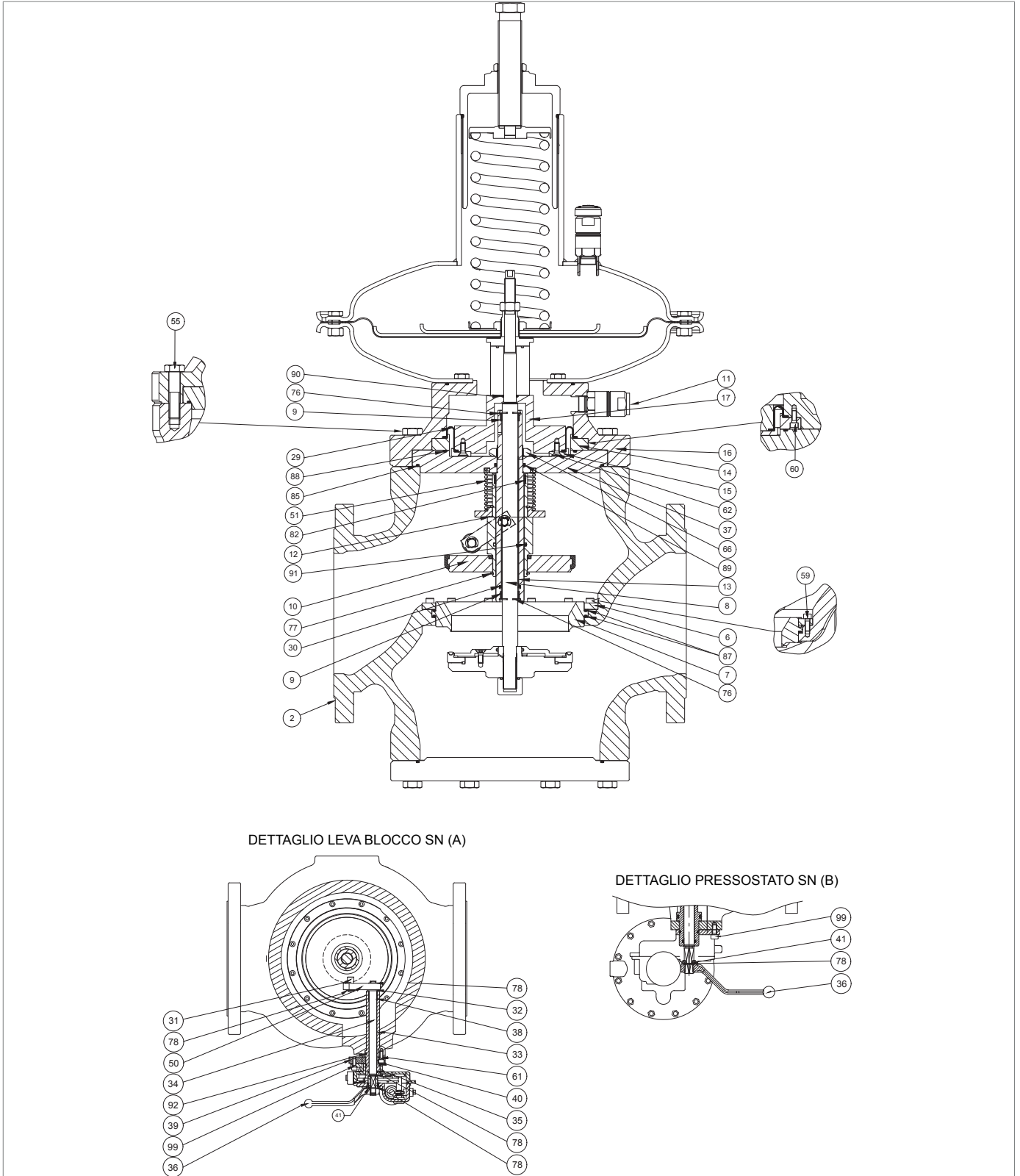





Fig. 9.53. NORVAL + SN 4"

Step	Action
1	Pull out the rod guide sleeve (13) together with the plug (10), the plug support (12), the O-ring (91), the shaft collar (77), the I/DWR ring (82) and the spring (51) from the flange spacer (37).
2	Remove the upper circlip (76).
3	Remove and replace the upper I/DWR ring (9). ! NOTICE! Before inserting the replacement I/DWR ring, clean the retaining slots with a cleaning solution.
4	Fit the upper circlip (76).
5	Remove the lower circlip (76).
6	Remove the lower I/DWR ring (9).
7	Remove and replace the lip seal (30).
8	Replace the lower I/DWR ring (9). ! NOTICE! Before inserting the replacement I/DWR ring, clean the retaining slots with a cleaning solution.
9	Fit the lower circlip (76).
10	Remove and replace the O-rings (85, 88, 89), taking care to lubricate them with synthetic grease. ! NOTICE! Before inserting the replacement O-rings, clean the retaining slots with a cleaning solution.
11	Remove the plug support (12) together with the I/DWR ring (82), the O-ring (91), the spring (51), the plug (10) and the shaft collar (77) from the rod guide sleeve (13).
12	Remove the shaft collar (77).
13	Remove and replace the plug (10).
14	Fit the shaft collar (77).
15	Remove the O-ring (91) and replace it, taking care to lubricate it with synthetic grease. ! NOTICE! Before inserting the replacement O-ring, clean the retaining slots with a cleaning solution.
16	Remove the I/DWR ring (9) and replace it, taking care to lubricate it with synthetic grease. ! NOTICE! Before inserting the replacement O-ring, clean the retaining slots with a cleaning solution.
17	Insert the plug support (12) together with the I/DWR ring (82), the O-ring (91), the spring (51), the plug (10) and the shaft collar (77) into the rod guide sleeve (13).
18	Insert the rod guide sleeve (13) together with the lower I/DWR ring (9), the upper I/DWR ring (9), the lower circlip (76), the upper circlip (76) the lip seal (30) into the flange (37).
19	Remove the coupling lever (36).
20	Remove the outer Seeger ring (78).



NORVAL + SN 4"

Step	Action
21	Remove the position indicator (41).
22	Remove the inner Seeger ring (78).
23	Remove the screws (99).
24	Pull out the SN pressure switch (detail B) from the bush (33).
25	Undo and remove the screws (61)
26	Remove the flange (39).
27	Pull out the bush (33), together with the O-rings (35, 40, 92) from the body (2).
28	Remove and replace the O-rings (35, 40, 92), taking care to lubricate them with synthetic grease.
28	<div style="border: 1px solid black; padding: 5px;">  NOTICE! Before inserting the replacement O-rings, clean the retaining slots with a cleaning solution. </div>
28	Position the bush (33), together with the O-rings (35, 40, 92) in the body (2).
29	Fit the flange (39).
30	Insert and fix the screws (61) according to the following tightening torques: <ul style="list-style-type: none"> • 1 - 3: tab. 9.86 <div style="border: 1px solid black; padding: 5px;">  NOTICE! Tighten the screws according to the cross diagram in paragraph 9.4.2.2. </div>
31	Insert the inner Seeger ring (78).
32	Position the SN pressure switch (detail B) in the bush (33)
33	Insert and fix the screws (99) according to the following tightening torques: <ul style="list-style-type: none"> • 1 - 3: tab. 9.86 <div style="border: 1px solid black; padding: 5px;">  NOTICE! Tighten the screws according to the cross diagram in paragraph 9.4.2.2. </div>
34	Fit the position indicator (41).
35	Fit the outer Seeger ring (52)
36	Fit the coupling lever (36).

Tab. 9.108.

 **WARNING!**

After maintenance of the regulator with SN slam-shut valve, go back to:

- 4", head 375TR: par. 9.4.4.8, step 60
- 4", head 375: par. 9.4.4.9, step 60
- 4", head 495: par. 9.4.4.10, step 56
- 4", head 630: par. 9.4.4.11, step 56

9.4.6.3 - NORVAL REGULATOR + SLAM-SHUT VALVE SN 6" - 8"

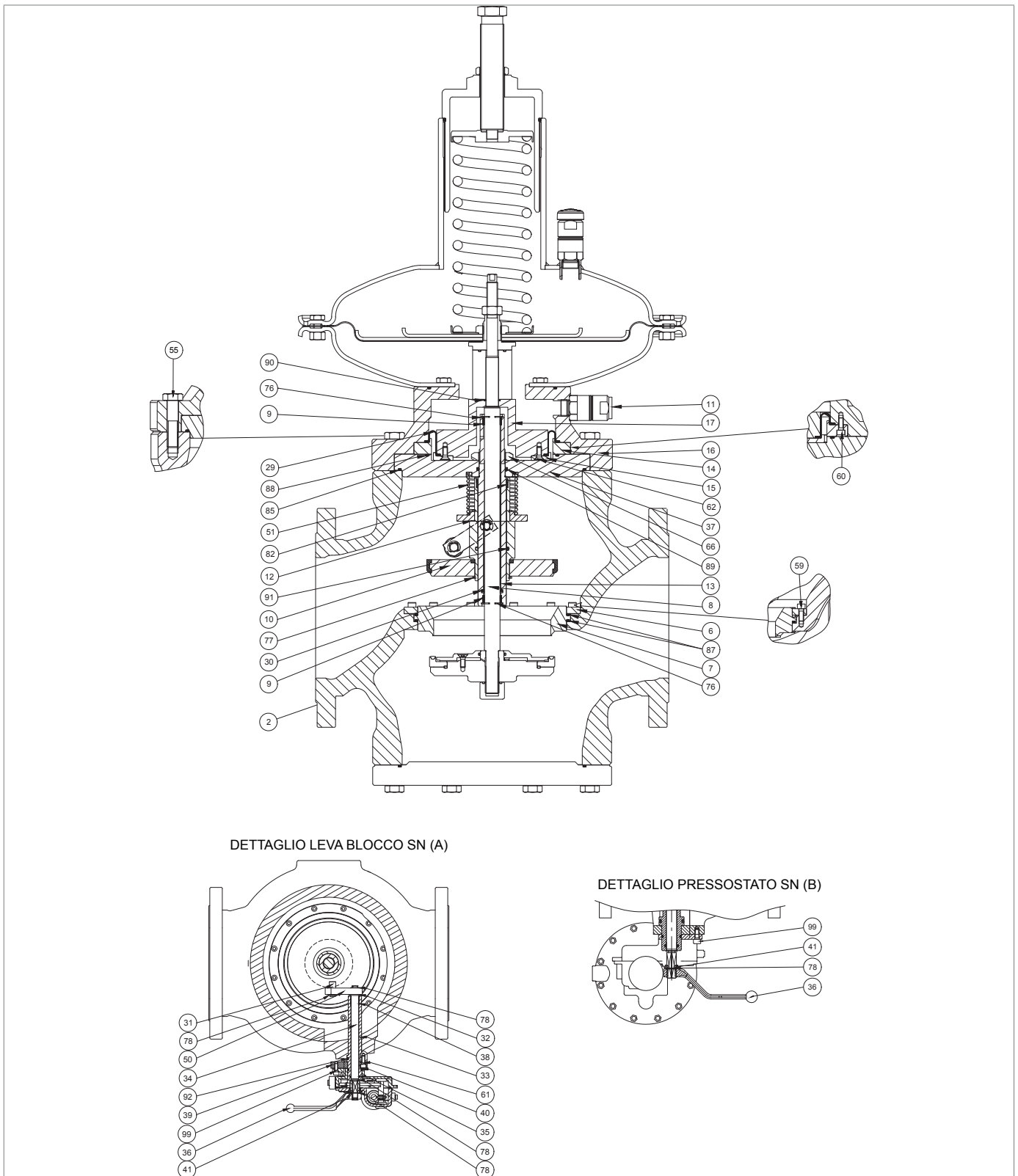
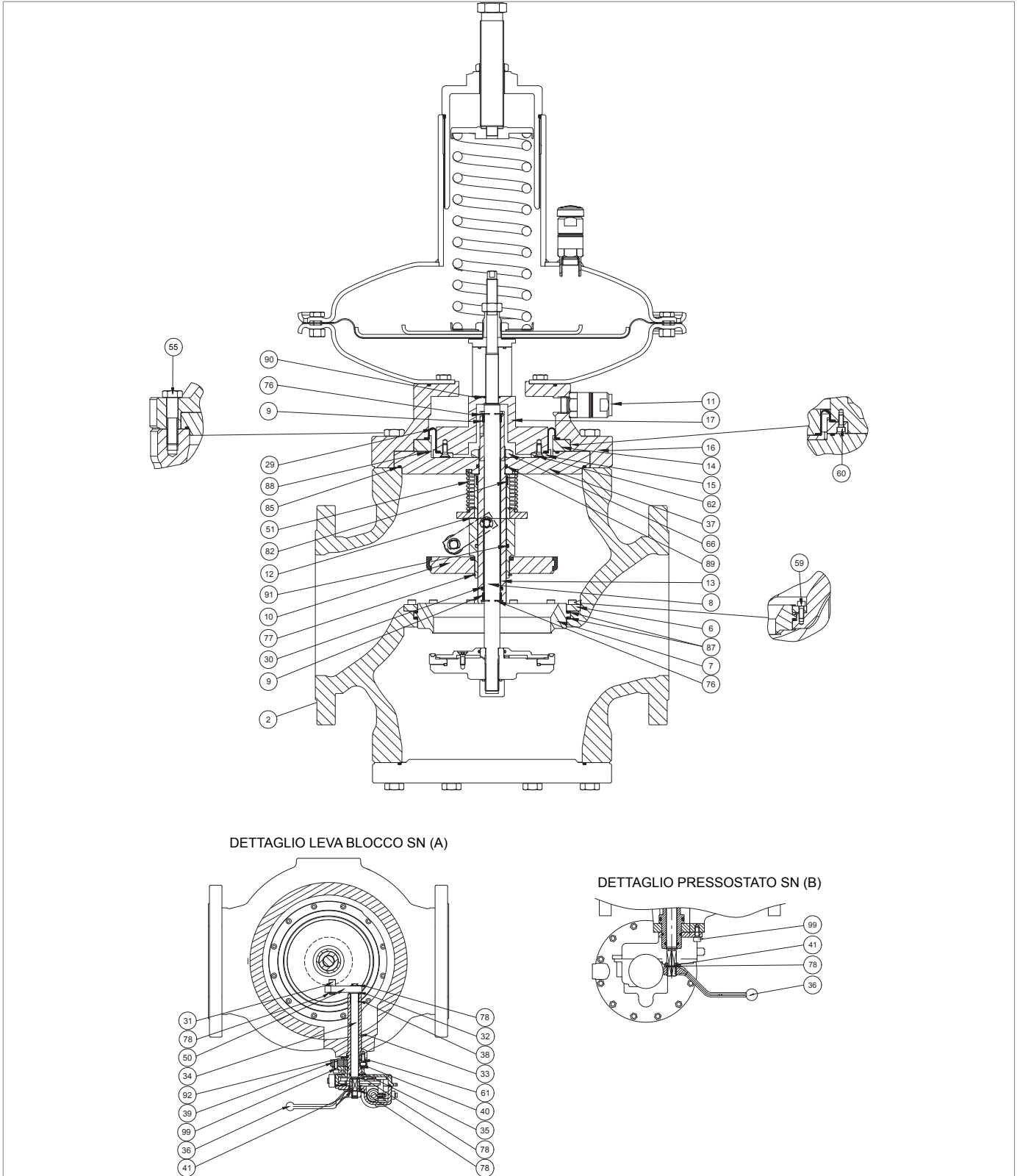





Fig. 9.54. NORVAL + SN 6" - 8"

Step	Action
1	Pull out the rod guide sleeve (13) together with the plug (10), the plug support (12), the O-ring (91), the shaft collar (77), the I/DWR ring (82) and the spring (51) from the flange spacer (37).
2	Remove the upper circlip (76).
3	Remove and replace the upper I/DWR ring (9). ! NOTICE! Before inserting the replacement I/DWR ring, clean the retaining slots with a cleaning solution.
4	Fit the upper circlip (76).
5	Remove the lower circlip (76).
6	Remove the lower I/DWR ring (9).
7	Remove and replace the lip seal (30).
8	Replace the lower I/DWR ring (9). ! NOTICE! Before inserting the replacement I/DWR ring, clean the retaining slots with a cleaning solution.
9	Fit the lower circlip (76).
10	Remove and replace the O-rings (85, 88, 89), taking care to lubricate them with synthetic grease. ! NOTICE! Before inserting the replacement O-rings, clean the retaining slots with a cleaning solution.
11	Remove the plug support (12) together with the I/DWR ring (82), the O-ring (91), the spring (51), the plug (10) and the shaft collar (77) from the rod guide sleeve (13).
12	Remove the shaft collar (77).
13	Remove and replace the plug (10).
14	Fit the shaft collar (77).
15	Remove the O-ring (91) and replace it, taking care to lubricate it with synthetic grease. ! NOTICE! Before inserting the replacement O-ring, clean the retaining slots with a cleaning solution.
16	Remove the I/DWR ring (82) and replace it, taking care to lubricate it with synthetic grease. ! NOTICE! Before inserting the replacement O-ring, clean the retaining slots with a cleaning solution.
17	Insert the plug support (12) together with the I/DWR ring (82), the O-ring (91), the spring (51), the plug (10) and the shaft collar (77) into the rod guide sleeve (13).
18	Insert the rod guide sleeve (13) together with the lower I/DWR ring (9), the upper I/DWR ring (9), the lower circlip (76), the upper circlip (76) the lip seal (30) into the flange (37).
19	Remove the coupling lever (36).
20	Remove the outer Seeger ring (78).



NORVAL + SN 6" - 8"

Step	Action
21	Remove the position indicator (41).
22	Remove the inner Seeger ring (78).
23	Remove the screws (99).
24	Pull out the SN pressure switch (detail B) from the bush (33).
25	Undo and remove the screws (61).
26	Remove the flange (39).
27	Pull out the bush (33), together with the O-rings (35, 40, 92) from the body (2).
28	Remove and replace the O-rings (35, 40, 92), taking care to lubricate them with synthetic grease.
28	 NOTICE! Before inserting the replacement O-rings, clean the retaining slots with a cleaning solution.
28	Position the bush (33), together with the O-rings (35, 40, 92) in the body (2).
29	Fit the flange (39).
30	Insert and fix the screws (61) according to the following tightening torques: <ul style="list-style-type: none"> • 6 - 8: tab. 9.87  NOTICE! Tighten the screws according to the cross diagram in paragraph 9.4.2.2.
31	Insert the inner Seeger ring (78).
32	Position the SN pressure switch (detail B) in the bush (33)
33	Insert and fix the screws (99) according to the following tightening torques: <ul style="list-style-type: none"> • 6 - 8: tab. 9.87  NOTICE! Tighten the screws according to the cross diagram in paragraph 9.4.2.2.
34	Fit the position indicator (41).
35	Fit the outer Seeger ring (78)
36	Fit the coupling lever (36).

Tab. 9.109.

 **WARNING!**

After maintenance of the SN slam-shut valve of the NORVAL regulator, go back to:

- 6" - 8", head 495: par. 9.4.4.12, step 61
- 6" - 8", head 630: par. 9.4.4.13, step 59
- 6" - 8", head 658: par. 9.4.4.14, step 65
- 6" - 8", head 817: par. 9.4.4.15, step 63

9.4.7 - MAINTENANCE OF PRESSURE SWITCH MOD. SN

9.4.7.1 - DISCONNECTION OF PRESSURE SWITCH MOD. SN

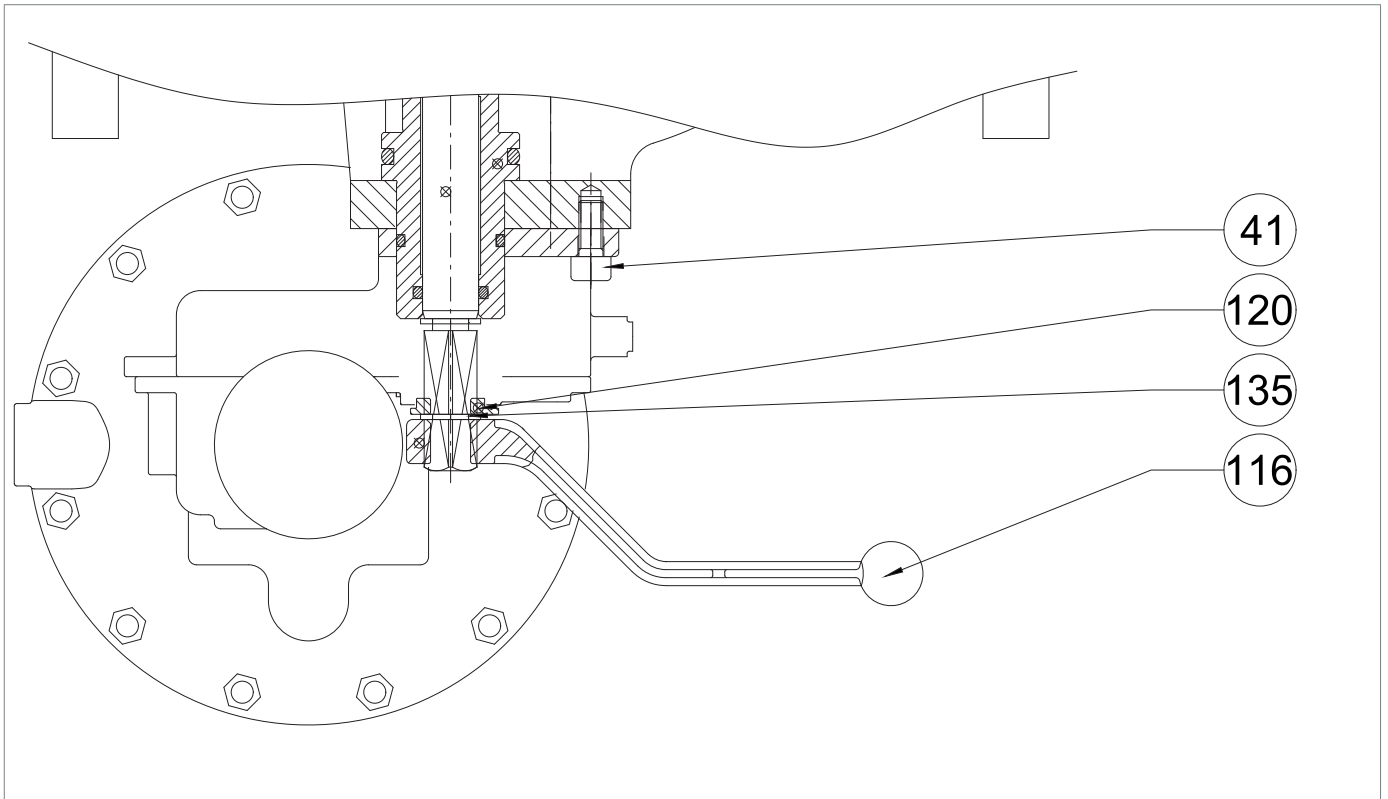

Fig. 9.55. Pressure switch mod. SN

To disconnect the pressure switches mod. SN, proceed as in tab. 9.110 (see fig. 9.55):

Step	Action
1	Remove the lever (116).
2	Remove the Seeger ring (135).
3	Remove the position indicator (120).
4	Remove the screws (41).

Tab. 9.110.

9.4.7.2 - PRESSURE SWITCH SN-91, SN-92

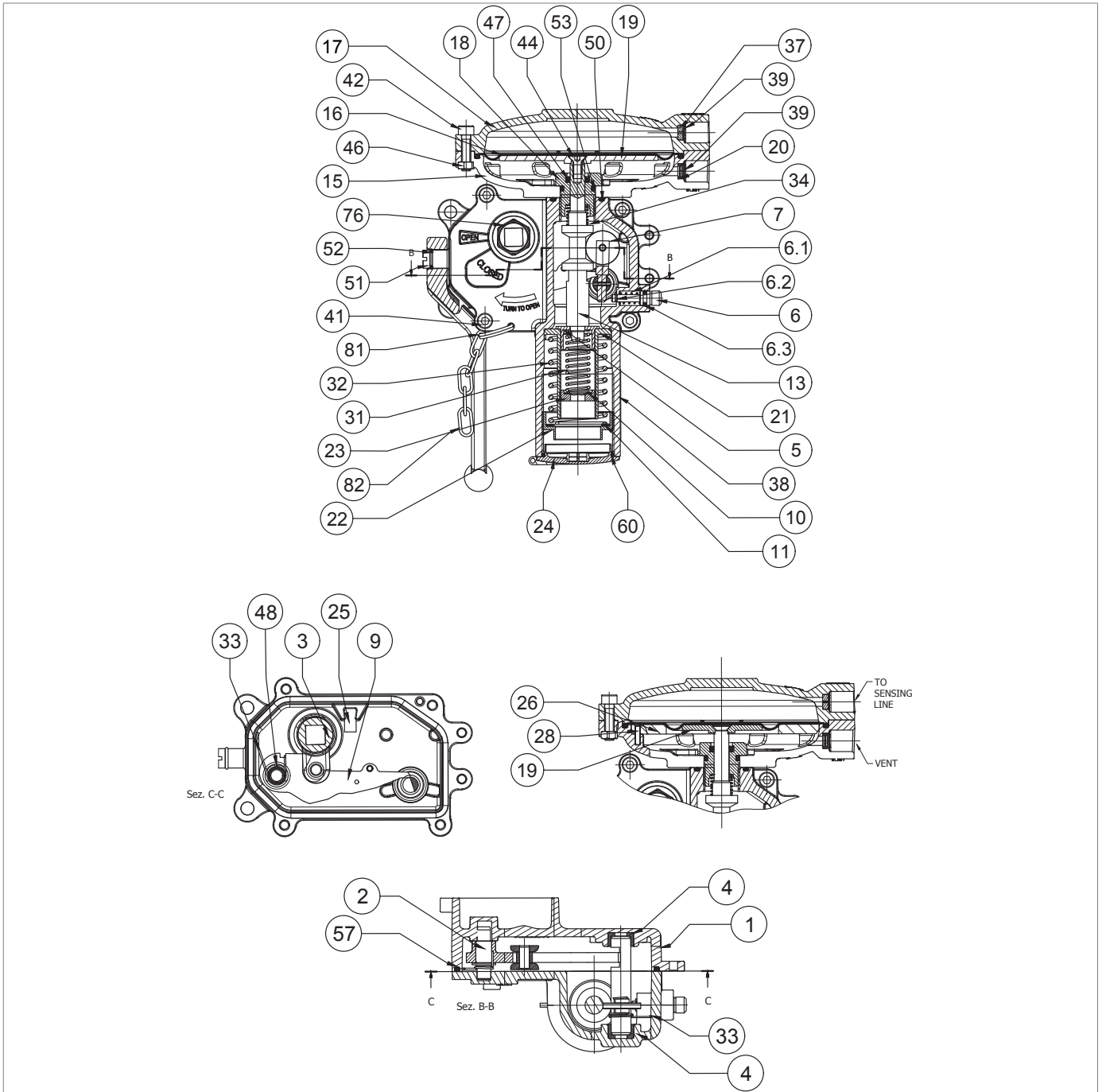
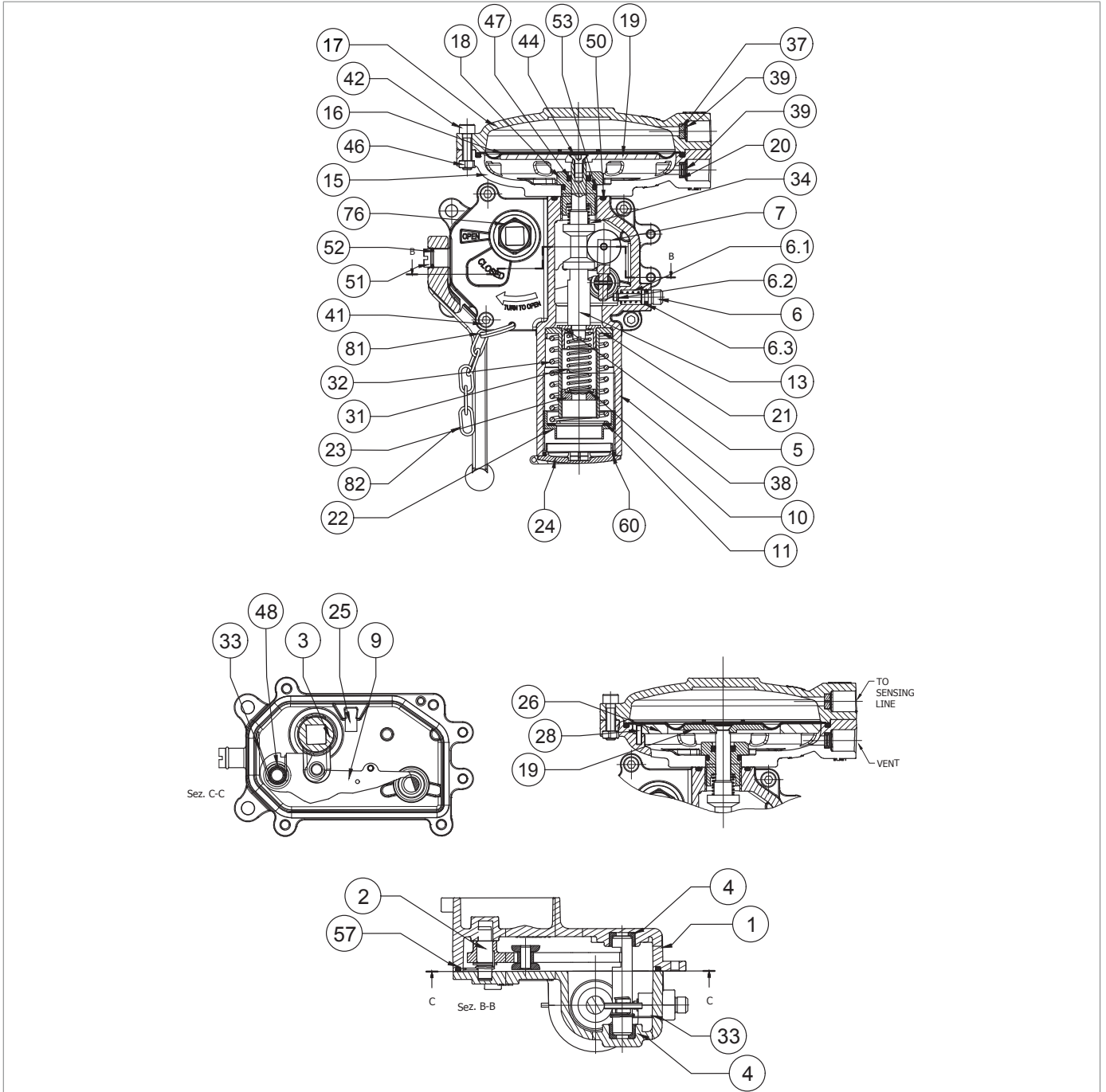



Fig. 9.56. Pressure switch SN-91, SN-92

Step	Action
1	Unscrew and remove the cap (24).
2	Remove the O-ring (60) from the cap (24) and replace it, taking care to lubricate it with synthetic grease. ! NOTICE! Before inserting the replacement O-ring, clean the retaining slots with a cleaning solution.
3	Undo and remove the screws (42) together with the nuts (46).
4	Remove the cover(17).
5	Remove the diaphragm (16).
6	Undo the screw (44) keeping the diaphragm protection disc (19) still.
7	Remove the diaphragm protection disc (19).
8	Unscrew and remove the slam-shut device guide (18).
9	Remove the flange (15).
10	Remove the O-ring (50) and replace it, taking care to lubricate it with synthetic grease. ! NOTICE! Before inserting the replacement O-rings, clean the retaining slots with a cleaning solution.
11	Remove the O-ring (53) from the bush (18) and replace it, taking care to lubricate it with synthetic grease. ! NOTICE! Before inserting the replacement O-rings, clean the retaining slots with a cleaning solution.
12	Remove the U-shaped ring (47) from the bush (18) and replace it, taking care to lubricate it with synthetic grease. ! NOTICE! Before inserting the replacement ring, clean the retaining slots with a cleaning solution.
13	Fit the flange (15).
14	Insert and fix the slam-shut device guide (18) according to the following tightening torque: <ul style="list-style-type: none"> • Pressure switch SN-91: tab. 9.88 • Pressure switch SN-92: tab. 9.88
15	Fit the diaphragm protection disc (19)
16	Insert and fix the screw (44) while keeping the diaphragm protection disc (19) still, according to the following tightening torques: <ul style="list-style-type: none"> • Pressure switch SN-91: tab. 9.88 • Pressure switch SN-92: tab. 9.88 ! NOTICE! Tighten the screws according to the cross diagram in paragraph 9.4.2.2.
17	Fit the diaphragm (16).
18	Fit the cover (17).



Pressure switch SN-91, SN-92

Step	Action
19	Insert and fix the screws (42) together with the nuts (46) according to the following tightening torque: <ul style="list-style-type: none"> • Pressure switch SN-91: tab. 9.88 • Pressure switch SN-92: tab. 9.88 <div style="border: 1px solid black; padding: 5px; margin-top: 10px;">  NOTICE! Tighten the screws according to the cross diagram in paragraph 9.4.2.2. </div>
20	Insert and fix the cap (24).

Tab. 9.111.

 **WARNING!**

Ensure that all parts have been fitted correctly.

9.4.7.3 - RECONNECTION OF PRESSURE SWITCH MOD. SN

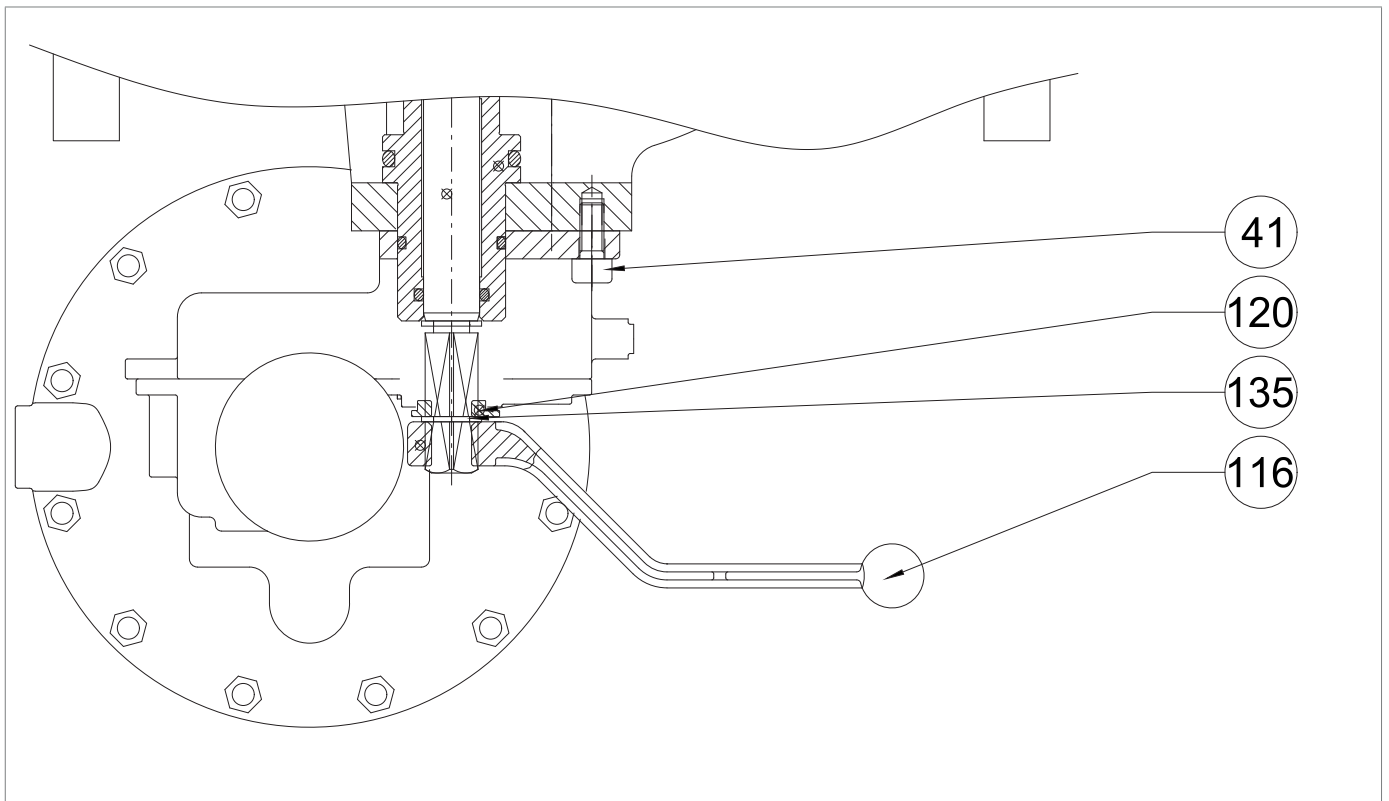

Fig. 9.57. Pressure switch mod. SN

To connect the pressure switches mod. SN, proceed as in tab. 9.112 (see fig. 9.57):

Step	Action
1	Insert and fix the screws (41) according to the following tightening torques: <ul style="list-style-type: none"> • Pressure switch SN-91: tab. 9.105 • Pressure switch SN-92: tab. 9.105
2	Fit the position indicator (120).
3	Fit the Seeger ring (135).
4	Fit the lever (116).

Tab. 9.112.

9.4.8 - PROCEDURE FOR RECOMMISSIONING AFTER MAINTENANCE

NOTICE!

For the recommissioning procedure, refer to the relevant paragraph.

10 - TROUBLESHOOTING

Below is a list of the cases (causes and services) that may occur over time in the form of malfunctions of various kinds. These situations depend on the conditions of the gas as well as on the natural ageing and wear of the materials.

10.1 - GENERAL WARNINGS

HAZARD!

Maintenance work must be carried out by qualified personnel:

- trained on workplace safety also based on the regulations in force in the place of installation of the work equipment;
- qualified and authorised to carry out activities related to the equipment.

WARNING!







PIETRO FIORENTINI S.p.A. shall not be held liable for any damage to people and property due to services:

- other than those described;
- performed according to methods other than those specified;
- carried out by unsuitable personnel.

NOTICE!

If an operating fault occurs and qualified personnel are not available for the specific service, call the PIETRO FIORENTINI S.p.A. Authorised Assistance Centre

10.2 - OPERATOR QUALIFICATION SPECIFICATION

Commissioning	
Operator qualification	<ul style="list-style-type: none"> • Mechanical maintenance technician; • Electrical maintenance technician; • Installer; • User's technician.
PPE required	<div style="display: flex; align-items: center; gap: 5px;">      </div> <div style="background-color: #f4a460; padding: 5px; margin-top: 5px;">  WARNING! </div> <p>The PPE listed in this table is related to the risk associated with the equipment. For the PPE required to protect against risks associated with the workplace, installation or operating conditions, please refer to:</p> <ul style="list-style-type: none"> • the regulations in force in the country of installation; • <u>any information provided by the Safety Manager at the installation facility.</u>
Equipment required	Refer to chapter 7 "Equipment for commissioning/maintenance".

Tab. 10.113.

10.3 - TROUBLESHOOTING PROCEDURES

For proper troubleshooting, proceed as follows:

- close the downstream shut-off valves;
- refer to the troubleshooting tables listed below.

10.4 - TROUBLESHOOTING TABLES

NOTICE!

Refer to chapter 9 “Maintenance and functional checks” for the pictures of the NORVAL regulator and its accessories.

10.4.1 - NORVAL REGULATOR TROUBLESHOOTING

WARNING!

If the incorporated slam-shut valve tripped, before any other operation, close the upstream and downstream shut-off valves (V1 and V2) of the line and discharge pressure.

Failure	Device	Possible causes	Service
Operation faults	REGULATOR	Rod (8) soiled or blocked	Clean
		Adjustment diaphragm (20) worn	Replace
		<ul style="list-style-type: none"> DN 1" - 3": lock nut (49) DN 4" - 8": lock nut (68) loosened	Tighten properly according to the tightening torque
		Sensing element obstructed or positioned incorrectly	Clean and reposition if needed
		Balancing diaphragm (29) worn	Replace
		I/DWR (9) soiled or worn	Clean and replace if needed
		Valve seat (7) with damaged profile	Replace
		Reinforced gasket (4) soiled or damaged	Clean and replace if needed
		Gasket support (3) loosened	Tighten properly
		<ul style="list-style-type: none"> DN 1" - 3": lower anti-pumping valve (VAP) (39) DN 4" - 8": lower anti-pumping valve (VAP) (11) soiled or damaged	Clean and replace if needed
		Spring (41) collapsed or out of level	Reposition and replace if needed
		Unsuitable spring (41)	Replace
	ER MONITOR	Balancing diaphragm (29) worn	Replace
		<ul style="list-style-type: none"> DN 1" - 3": lock nut (49) DN 4" - 8": lock nut (68) loosened	Tighten properly according to the tightening torque

Failure	Device	Possible causes	Service
Pumping	REGULATOR	Upper anti-pumping valve (VAP) (25) soiled or damaged	Clean and replace if needed
		<ul style="list-style-type: none"> DN 1" - 3": lower anti-pumping valve (VAP) (39) DN 4" - 8": lower anti-pumping valve (VAP) (11) soiled or damaged	Clean and replace if needed
		I/DWR (9) worn	Replace
		Sensing element soiled, obstructed or positioned incorrectly	Clean and reposition, if needed
		Valve seat (7) with damaged profile	Replace
		Balancing diaphragm (29) worn	Replace
		Reinforced gasket (4) soiled or damaged	Clean and replace if needed
Failed sealing or zero flow	REGULATOR	<ul style="list-style-type: none"> DN 1" - 3": O-ring (67) DN 4" - 8": O-ring (94, 95) soiled or damaged	Clean and replace if needed
		<ul style="list-style-type: none"> DN 1" - 3": O-ring (60) DN 4" - 8": O-ring (90) soiled or damaged	Clean and replace if needed
		Failed sealing: <ul style="list-style-type: none"> DN 1" - 3": O-ring (66) DN 4" - 8": O-ring (87) 	Clean and replace if needed
		Balancing diaphragm (29) worn	Replace
		Reinforced gasket (4) soiled or damaged	Clean and replace if needed
	ER MONITOR	<ul style="list-style-type: none"> DN 1" - 3": O-ring (71) DN 4" - 8": O-ring (94) soiled or damaged	Clean and replace if needed
		<ul style="list-style-type: none"> DN 1" - 3": O-ring (60) DN 4" - 8": O-ring (90) soiled or damaged	Clean and replace if needed

Failure	Device	Possible causes	Service
Downstream pressure supply increases	REGULATOR	Diaphragm (20) worn or damaged	Replace
		I/DWR (9) soiled or damaged	Clean and replace if needed
		Rod (8) blocked while opening	Clean
		Reinforced gasket (4) soiled or damaged	Clean and replace if needed
		Valve seat (7) with damaged profile	Replace
		<ul style="list-style-type: none"> DN 1" - 3": lower anti-pumping valve (VAP) (39) DN 4" - 8": lower anti-pumping valve (VAP) (11) soiled or damaged	Clean and replace if needed
		Sensing element soiled, obstructed or positioned incorrectly	Clean and reposition, if needed
	ER MONITOR	Balancing diaphragm (29) worn	Replace
Downstream pressure supply decreases	REGULATOR	No upstream pressure (Pu)	Check the upstream pressure
		Rod (8) blocked	Clean
		I/DWR (9) soiled or damaged	Clean and replace if needed
		Unsuitable spring (41)	Replace

Tab. 10.114.

10.4.2 - SN SLAM-SHUT VALVE TROUBLESHOOTING

Failure	Device	Possible causes	Service
Incorrect tripping pressure	PRESSURE SWITCH MOD. SN	Wrong calibration: <ul style="list-style-type: none"> • maximum spring-load (32) • minimum spring-load (31) 	Repeat calibration by adjusting the ring nuts
		Leverages with friction	Clean and lubricate the levers and if needed replace the pressure switch
		Springs (31, 32) collapsed	Replace
		Springs (31, 32) out of level	Refit
Impossible to reset	PRESSURE SWITCH MOD. SN	Wrong calibration: <ul style="list-style-type: none"> • maximum spring-load (32) • minimum spring-load (31) 	Repeat calibration by adjusting the ring nuts
		Downstream pressure is not consistent with the minimum and/or maximum setting of the slam-shut device	Adjust the downstream pressure
		Lever broken or chipped	Replace pressure switch
		Diaphragm breakage (16) if there is a minimum spring-load	Replace the diaphragm (16)
		Manual release button (6) locked	Clean and lubricate
Failure to provide service	SN SLAM-SHUT VALVE	<ul style="list-style-type: none"> • DN 1" - 3": plug (12) • DN 4" - 8": plug (2) locked in opening position 	Clean and lubricate if needed
		<ul style="list-style-type: none"> • DN 1" - 3": I/DWR (55) • DN 4" - 8": I/DWR (82) soiled or damaged 	Clean and replace if needed
		<ul style="list-style-type: none"> • DN 1" - 3": spring (42) • DN 4" - 8": spring (51) collapsed 	Replace
		Rod (34) blocked	Clean and lubricate
	PRESSURE SWITCH MOD. SN	Diaphragm breakage (16) if there is a minimum spring-load	Replace the diaphragm (16)
		Lever broken or chipped	Replace pressure switch
Downstream pressure increase with closing slam-shut device	SN SLAM-SHUT VALVE	Valve seat (7) with damaged profile	Replace
		Failed sealing: <ul style="list-style-type: none"> • DN 1" - 3": O-ring (63) • DN 4" - 8": O-ring (91) 	Clean and replace if needed
		Failed tightness of the reinforced gasket (10) on main outer surface	Clean and replace if needed
		Failed tightness of the reinforced gasket (10) on bypass inner surface	Clean and replace if needed
		Failed sealing: <ul style="list-style-type: none"> • DN 1" - 3": O-ring (66) • DN 4" - 8": O-ring (87) 	Clean and replace if needed

Tab. 10.115.

11 - UNINSTALLATION AND DISPOSAL

11.1 - GENERAL SAFETY WARNINGS

HAZARD!



Make sure that there are no potentially explosive ignition sources in the work area set up to uninstall and/or dispose of the equipment.

WARNING!

Before proceeding with uninstallation and disposal, make the equipment safe by disconnecting it from any power supply.

11.2 - QUALIFICATION OF THE OPERATORS IN CHARGE

Commissioning

Operator qualification	Installer
PPE required	 <p> WARNING!</p> <p>The PPE listed in this table is related to the risk associated with the equipment. For the PPE required to protect against risks associated with the workplace, installation or operating conditions, please refer to:</p> <ul style="list-style-type: none"> • the regulations in force in the country of installation; • any information provided by the Safety Manager at the installation facility.
Equipment required	Refer to chapter 7 “Equipment for commissioning/maintenance”.

Tab. 11.116.

11.3 - UNINSTALLATION

ATTENTION!

Before uninstalling the equipment, completely drain the fluid in the reduction line and inside the equipment.

NOTICE!

To uninstall the equipment, refer to the installation steps (see chapter 6 “Installation”) and proceed in reverse order.

11.4 - INFORMATION REQUIRED IN CASE OF RE-INSTALLATION

NOTICE!

Should the equipment be reused after uninstallation, refer to chapters:

- 6 “Installation”;
- 8 “Commissioning”.

11.5 - DISPOSAL INFORMATION

NOTICE!

Bear in mind that the laws in force in the country of installation must be complied with. Illegal or improper disposal involves the application of the penalties provided for by the legislation in force in the country of installation.

NOTICE!

Proper disposal prevents damage to humans and the environment and promotes the reuse of precious raw materials.

The equipment was manufactured with materials that can be recycled by specialised companies. For proper disposal of the equipment, proceed as specified in table 11.117:

Step	Action
1	Set up a large work area free from obstacles where to safely dismantle the equipment.
2	Sort the various components by type of material for easier recycling through separate collection.
3	Send the materials obtained in Step 2 to a specialised company.

Tab. 11.117.

The equipment in any configuration consists of the following materials:

Material	Disposal/recycling indications
Plastic	It must be dismantled and disposed of separately.
Lubricants/Oils	They must be collected and delivered to the appropriate specialised and authorised collection and disposal centres.
Steel/Cast-iron	Disassemble and collect separately. It must be recycled through the specific collection centres.
Stainless steel	Disassemble and collect separately. It must be recycled through the specific collection centres.
Aluminium	Disassemble and collect separately. It must be recycled through the specific collection centres.
Pneumatic/electric components	They must be dismantled in order to be reused if they are still in good condition or, if possible, overhauled and recycled.

Tab. 11.118.

NOTICE!

Refer to chapter 9 “Maintenance and functional checks” to better identify the composition of the equipment and its parts.

12 - RECOMMENDED SPARE PARTS

12.1 - GENERAL WARNINGS

NOTICE!

If non-original spare parts are used, PIETRO FIORENTINI S.p.A. their declared performance cannot be guaranteed.

It is recommended to use PIETRO FIORENTINI S.p.A. original spare parts

PIETRO FIORENTINI S.p.A. shall not be held liable for any damage caused by using non-original parts.

12.2 - HOW TO REQUEST SPARE PARTS

NOTICE!

For specific information, please refer to the sales network of PIETRO FIORENTINI S.p.A.

13 - CALIBRATION TABLES

13.1 - CALIBRATION TABLES FOR REGULATOR

NORVAL 1" - 4" CONTROL HEAD 375TR							
Pos.	Spring item code	Spring colour	d	Lo	De	Min.	Max.
1	2704390	Green	11	260	85	0,9	1,5
2	2704615	Blue	12			1,501	2,2
3	2704820	Purple	13			2,201	3,1
4	2705010	Light blue	15			3,101	4,4

d = Wire Diameter (mm) **Lo** = Spring Length (mm) **De** = Outside Diameter (mm) **Min./Max.** = Pressure (bar)

Tab. 13.119.

NORVAL 1" - 4" CONTROL HEAD 375TR (INVERTED)							
Pos.	Spring item code	Spring colour	d	Lo	De	Min.	Max.
1	2704390	Green	11	260	85	0,9	1,5
2	2704615	Blue	12			1,501	2,2
3	2704820	Purple	13			2,201	3,1
4	2705010	Light blue	15			3,101	4,4

d = Wire Diameter (mm) **Lo** = Spring Length (mm) **De** = Outside Diameter (mm) **Min./Max.** = Pressure (bar)

Tab. 13.120.

NORVAL 1" - 2" CONTROL HEAD 375							
Pos.	Spring item code	Spring colour	d	Lo	De	Min.	Max.
1	2702755	White	6,5	300	85	0,8	0,115
2	2702975	Yellow	7			0,116	0,16
3	2703175	Orange	7,5			0,161	0,21
4	2703360	Red	8			0,211	0,265
5	2703525	Green	8,5			0,266	0,33
6	2703745	Black	9			0,331	0,4
7	2703895	Blue	9,5			0,401	0,48
8	2704062	Brown	10			0,481	0,7
9	2704400	Light blue	11			0,701	0,9
10	2704515	White/Yellow	11,5			0,901	1,1

d = Wire Diameter (mm) **Lo** = Spring Length (mm) **De** = Outside Diameter (mm) **Min./Max.** = Pressure (bar)

Tab. 13.121.

NORVAL 1" - 2" CONTROL HEAD 375 (INVERTED)

Pos.	Spring item code	Spring colour	d	Lo	De	Min.	Max.
1	2702755	White	6,5	300	85	0,8	0,115
2	2702975	Yellow	7			0,116	0,16
3	2703175	Orange	7,5			0,161	0,21
4	2703360	Red	8			0,211	0,265
5	2703525	Green	8,5			0,266	0,33
6	2703745	Black	9			0,331	0,4
7	2703895	Blue	9,5			0,401	0,48
8	2704062	Brown	10			0,481	0,7
9	2704400	Light blue	11			0,701	1,05

d = Wire Diameter (mm) **Lo** = Spring Length (mm) **De** = Outside Diameter (mm) **Min./Max.** = Pressure (bar)

Tab. 13.122.

NORVAL 2" 1/2 - 4" CONTROL HEAD 375

Pos.	Spring item code	Spring colour	d	Lo	De	Min.	Max.
1	2704062	Brown	10	300	85	0,47	0,7
2	2704400	Light blue	11			0,701	0,9
3	2704615	Blue	12	260		0,901	1,25
4	2704820	Purple	13			1,251	1,75
5	2705010	Light blue	15			1,751	2,8

d = Wire Diameter (mm) **Lo** = Spring Length (mm) **De** = Outside Diameter (mm) **Min./Max.** = Pressure (bar)

Tab. 13.123.

NORVAL 2" 1/2 - 4" CONTROL HEAD 375 (INVERTED)

Pos.	Spring item code	Spring colour	d	Lo	De	Min.	Max.
1	2704062	Brown	10	300	85	0,47	0,7
2	2704400	Light blue	11			0,701	0,9
3	2704615	Blue	12	260		0,901	1,3
4	2704820	Purple	13			1,301	1,75
5	2705010	Light blue	15			1,751	2,8

d = Wire Diameter (mm) **Lo** = Spring Length (mm) **De** = Outside Diameter (mm) **Min./Max.** = Pressure (bar)

Tab. 13.124.

NORVAL 1" - 2" CONTROL HEAD 495

Pos.	Spring item code	Spring colour	d	Lo	De	Min.	Max.
1	2701966	Red	4,8	350	85	0,016	0,022
2	2702205	Green	5			0,023	0,027
3	2702385	Black	5,5			0,028	0,033
4	2702565	Blue	6			0,034	0,04
5	2702755	White	6,5	300		0,041	0,058
6	2702975	Yellow	7			0,059	0,083

d = Wire Diameter (mm) **Lo** = Spring Length (mm) **De** = Outside Diameter (mm) **Min./Max.** = Pressure (bar)

Tab. 13.125.

NORVAL 1" - 2" CONTROL HEAD 495 (INVERTED)							
Pos.	Spring item code	Spring colour	d	Lo	De	Min.	Max.
1	2701966	Red	4,8	350	85	0,008	0,011
2	2702205	Green	5			0,012	0,015
3	2702385	Black	5,5			0,016	0,021
4	2702565	Blue	6			0,022	0,026
5	2702755	White	6,5	300	85	0,027	0,042
6	2702975	Yellow	7			0,043	0,067
7	2703175	Orange	7,5			0,068	0,09

d = Wire Diameter (mm) **Lo** = Spring Length (mm) **De** = Outside Diameter (mm) **Min./Max.** = Pressure (bar)

Tab. 13.126.

NORVAL 2" 1/2 - 4" CONTROL HEAD 495							
Pos.	Spring item code	Spring colour	d	Lo	De	Min.	Max.
1	2703175	Orange	7,5	300	85	0,08	0,105
2	2703360	Red	8			0,106	0,13
3	2703525	Green	8,5			0,131	0,16
4	2703745	Black	9			0,161	0,2
5	2703895	Blue	9,5			0,201	0,25
6	2704062	Brown	10			0,251	0,32
7	2704400	Light blue	11			0,321	0,43
8	2704515	White/Yellow	11,5			0,431	0,53

d = Wire Diameter (mm) **Lo** = Spring Length (mm) **De** = Outside Diameter (mm) **Min./Max.** = Pressure (bar)

Tab. 13.127.

NORVAL 2" 1/2 - 4" CONTROL HEAD 495 (INVERTED)							
Pos.	Spring item code	Spring colour	d	Lo	De	Min.	Max.
1	2703360	Red	8	300	85	0,08	0,115
2	2703525	Green	8,5			0,116	0,145
3	2703745	Black	9			0,146	0,18
4	2703895	Blue	9,5			0,181	0,23
5	2704062	Brown	10			0,231	0,3
6	2704400	Light blue	11			0,301	0,5

d = Wire Diameter (mm) **Lo** = Spring Length (mm) **De** = Outside Diameter (mm) **Min./Max.** = Pressure (bar)

Tab. 13.128.

NORVAL 6" - 8" CONTROL HEAD 495

Pos.	Spring item code	Spring colour	d	Lo	De	Min.	Max.
1	2704670	White/Yellow	12	400	100	0,39	0,52
2	2704108	Purple	10		100	0,521	0,62
	2703720	White	9		65		
3	2704440	Light blue	11		100	0,621	0,73
	2703720	White	9		65		
4	2704670	White/Yellow	12		100	0,731	0,92
	2703720	White	9		65		
5	2704670	White/Yellow	12		100	0,921	1,3
	2704210	Red	10,5		65		
6	2704985	White/Blue	14		100	1,301	1,8
	2704210	Red	10,5		65		

d = Wire Diameter (mm) **Lo** = Spring Length (mm) **De** = Outside Diameter (mm) **Min./Max.** = Pressure (bar)

Tab. 13.129.

NORVAL 6" - 8" CONTROL HEAD 495 (INVERTED)

Pos.	Spring item code	Spring colour	d	Lo	De	Min.	Max.
1	2704670	White/Yellow	12	400	100	0,34	0,46
2	2704108	Purple	10		100	0,461	0,58
	2703720	White	9		65		
3	2704440	Light blue	11		100	0,581	0,67
	2703720	White	9		65		
4	2704670	White/Yellow	12		100	0,671	0,86
	2703720	White	9		65		
5	2704670	White/Yellow	12		100	0,861	1,24
	2704210	Red	10,5		65		
6	2704985	White/Blue	14		100	1,241	1,8
	2704210	Red	10,5		65		

d = Wire Diameter (mm) **Lo** = Spring Length (mm) **De** = Outside Diameter (mm) **Min./Max.** = Pressure (bar)

Tab. 13.130.

NORVAL 2" 1/2 - 3" CONTROL HEAD 630

Pos.	Spring item code	Spring colour	d	Lo	De	Min.	Max.
1	2701863	Brown	4,5	350	85	0,01	0,013
2	2702205	Green	5			0,014	0,017
3	2702385	Black	5,5			0,018	0,027
4	2702755	White	6,5	300		0,022	0,032
5	2702975	Yellow	7			0,033	0,046
6	2703175	Orange	7,5			0,047	0,058
7	2703360	Red	8			0,059	0,08

d = Wire Diameter (mm) **Lo** = Spring Length (mm) **De** = Outside Diameter (mm) **Min./Max.** = Pressure (bar)

Tab. 13.131.

NORVAL 2" 1/2 - 3" CONTROL HEAD 630 (INVERTED)

Pos.	Spring item code	Spring colour	d	Lo	De	Min.	Max.
1	2701863	Brown	4,5	350	85	0,01	0,013
2	2702205	Green	5			0,014	0,017
3	2702385	Black	5,5			0,018	0,027
4	2702755	White	6,5	300		0,028	0,032
5	2702975	Yellow	7			0,033	0,046
6	2703175	Orange	7,5			0,047	0,058
7	2703360	Red	8			0,059	0,08

d = Wire Diameter (mm) **Lo** = Spring Length (mm) **De** = Outside Diameter (mm) **Min./Max.** = Pressure (bar)

Tab. 13.132.

NORVAL 4" CONTROL HEAD 630

Pos.	Spring item code	Spring colour	d	Lo	De	Min.	Max.
1	2701863	Brown	4,5	350	85	0,012	0,014
2	2701966	Red	4,8			0,015	0,017
3	2702385	Black	5,5			0,018	0,024
4	2702755	White	6,5	300		0,025	0,033
5	2702975	Yellow	7			0,034	0,048
6	2703175	Orange	7,5			0,049	0,06
7	2703360	Red	8			0,061	0,08

d = Wire Diameter (mm) **Lo** = Spring Length (mm) **De** = Outside Diameter (mm) **Min./Max.** = Pressure (bar)

Tab. 13.133.

NORVAL 4" CONTROL HEAD 630 (INVERTED)

Pos.	Spring item code	Spring colour	d	Lo	De	Min.	Max.
1	2702205	Green	5	350	85	0,009	0,011
2	2702385	Black	5,5			0,012	0,015
3	2702755	White	6,5	300		0,016	0,024
4	2702975	Yellow	7			0,025	0,037
5	2703175	Orange	7,5			0,038	0,052
6	2703360	Red	8			0,053	0,066
7	2703525	Green	8,5			0,067	0,09

d = Wire Diameter (mm) **Lo** = Spring Length (mm) **De** = Outside Diameter (mm) **Min./Max.** = Pressure (bar)

Tab. 13.134.

NORVAL 6" - 8" CONTROL HEAD 630

Pos.	Spring item code	Spring colour	d	Lo	De	Min.	Max.
1	2704670	White/Yellow	12	400	100	0,22	0,29
2	2704108	Purple	10		100	0,291	0,35
	2703720	White	9		65		
3	2704440	Light blue	11		100	0,351	0,4
	2703720	White	9		65		
4	2704670	White/Yellow	12		100	0,401	0,51
	2703720	White	9		65		
5	2704670	White/Yellow	12		100	0,510	0,65
	2704210	Red	10,5		65		

d = Wire Diameter (mm) **Lo** = Spring Length (mm) **De** = Outside Diameter (mm) **Min./Max.** = Pressure (bar)

Tab. 13.135.

NORVAL 6" - 8" CONTROL HEAD 630 (INVERTED)

Pos.	Spring item code	Spring colour	d	Lo	De	Min.	Max.
1	2704670	White/Yellow	12	400	100	0,225	0,26
2	2704108	Purple	10		100	0,261	0,315
	2703720	White	9		65		
3	2704440	Light blue	11		100	0,316	0,38
	2703720	White	9		65		
4	2704670	White/Yellow	12		100	0,381	0,48
	2703720	White	9		65		
5	2704670	White/Yellow	12		100	0,481	0,6
	2704210	Red	10,5		65		

d = Wire Diameter (mm) **Lo** = Spring Length (mm) **De** = Outside Diameter (mm) **Min./Max.** = Pressure (bar)

Tab. 13.136.

NORVAL 6" - 8" CONTROL HEAD 658

Pos.	Spring item code	Spring colour	d	Lo	De	Min.	Max.
1	2703930	Brown	9,5	400	100	0,075	0,095
2	2704108	Purple	10		100	0,096	0,13
3	2704440	Light blue	11		100	0,131	0,17
4	2704670	White/Yellow	12		100	0,171	0,22
5	2704108	Purple	10		100	0,221	0,275
	2703720	White	9		65		
6	2704440	Light blue	11		100	0,276	0,325
	2703720	White	9		65		
7	2704670	White/Yellow	12		100	0,326	0,405
	2703720	White	9		65		

d = Wire Diameter (mm) **Lo** = Spring Length (mm) **De** = Outside Diameter (mm) **Min./Max.** = Pressure (bar)

Tab. 13.137.

NORVAL 6" - 8" CONTROL HEAD 658 (INVERTED)							
Pos.	Spring item code	Spring colour	d	Lo	De	Min.	Max.
1	2704108	Purple	10		100	0,093	0,13
2	2704440	Light blue	11		100	0,131	0,17
3	2704670	White/Yellow	12		100	0,171	0,22
4	2704108	Purple	10		100	0,221	0,275
	2703720	White	9		65		
5	2704440	Light blue	11		100	0,276	0,325
	2703720	White	9		65		
6	2704670	White/Yellow	12		100	0,326	0,405
	2703720	White	9		65		

d = Wire Diameter (mm) **Lo** = Spring Length (mm) **De** = Outside Diameter (mm) **Min./Max.** = Pressure (bar)

Tab. 13.138.

NORVAL 6" - 8" CONTROL HEAD 817							
Pos.	Spring item code	Spring colour	d	Lo	De	Min.	Max.
1	2702599	White	6	300	85	0,012	0,014
2	2702790	Yellow	6,5			0,015	0,017
3	2703015	Orange	7			0,018	0,02
4	2703199	Red	7,5			0,021	0,024
5	2703380	Green	8			0,025	0,03
6	2703560	Black	8,5			0,031	0,038
7	2703827	Blue	9			0,039	0,48
8	2703930	Brown	9,5			0,049	0,061
9	2704108	Purple	10			0,062	0,079

d = Wire Diameter (mm) **Lo** = Spring Length (mm) **De** = Outside Diameter (mm) **Min./Max.** = Pressure (bar)

Tab. 13.139.

NORVAL 6" - 8" CONTROL HEAD 817 (INVERTED)							
Pos.	Spring item code	Spring colour	d	Lo	De	Min.	Max.
1	2703380	Green	8	400	100	0,008	0,012
2	2703560	Black	8,5			0,013	0,02
3	2703827	Blue	9			0,021	0,03
4	2703930	Brown	9,5			0,031	0,042
5	2704108	Purple	10			0,043	0,068
6	2704440	Light blue	11			0,069	0,095

d = Wire Diameter (mm) **Lo** = Spring Length (mm) **De** = Outside Diameter (mm) **Min./Max.** = Pressure (bar)

Tab. 13.140.

13.2 - CALIBRATION TABLES FOR PRESSURE SWITCHES MDE. SN-91, SN-92

Below are the calibration tables for the pressure switches that may be installed in the incorporated slam-shut valve:

Mod. SN-91 - Max pressure							
Pos.	Spring item code	Spring colour	d	Lo	De	Min.	Max.
1	2700680	Brown	2.3	60	35	0.025	0.045
2	2700830	Red/black	2.5			0.046	0.076
3	2700920	White/yellow	2.8			0.076	0.1
4	2701040	White/orange	3			0.101	0.165
5	2701260	White	3.5			0.166	0.3
6	2701530	Yellow	4			0.301	0.58
7	2701790	Yellow/black	4.5			0.581	0.9
8	2702070	Orange	5			0.901	1.1

d = Wire Diameter (mm) **Lo** = Spring Length (mm) **De** = Outside Diameter (mm) **Min./Max.** = Pressure (bar)

Tab. 13.141.

Mod. SN-91 - Min pressure							
Pos.	Spring item code	Spring colour	d	Lo	De	Min.	Max.
1	2700338	White	1.3	40	15	0.01	0.025
2	2700377	Yellow	1.5			0.026	0.045
3	2700464	Orange	1.7			0.046	0.095
4	2700513	Red	2			0.096	0.125
5	2700713	Green	2.3			0.126	0.2
6	2700750	Black	2.5			0.201	0.5
7	2700985	Brown	3			0.501	0.9

d = Wire Diameter (mm) **Lo** = Spring Length (mm) **De** = Outside Diameter (mm) **Min./Max.** = Pressure (bar)

Tab. 13.142.

Mod. SN-91 (Norval/SCN inverted) - Max pressure							
Pos.	Spring item code	Spring colour	d	Lo	De	Min.	Max.
1	2700680	Brown	2.3	60	35	0.025	0.045
2	2700830	Red/black	2.5			0.046	0.076
3	2700920	White/yellow	2.8			0.076	0.1
4	2701040	White/orange	3			0.101	0.165
5	2701260	White	3.5			0.166	0.3
6	2701530	Yellow	4			0.301	0.58
7	2701790	Yellow/black	4.5			0.581	0.9
8	2702070	Orange	5			0.901	1.1

d = Wire Diameter (mm) **Lo** = Spring Length (mm) **De** = Outside Diameter (mm) **Min./Max.** = Pressure (bar)

Tab. 13.143.

Mod. SN-91 (Norval/SCN inverted) - Min pressure

Pos.	Spring item code	Spring colour	d	Lo	De	Min.	Max.
1	2700338	White	1.3	40	15	0.01	0.025
2	2700377	Yellow	1.5			0.026	0.045
3	2700464	Orange	1.7			0.046	0.095
4	2700513	Red	2			0.096	0.125
5	2700713	Green	2.3			0.126	0.2
6	2700750	Black	2.5			0.201	0.5
7	2700985	Brown	3			0.501	0.9

d = Wire Diameter (mm) **Lo** = Spring Length (mm) **De** = Outside Diameter (mm) **Min./Max.** = Pressure (bar)

Tab. 13.144.

Mod. SN-92 - Max pressure

Pos.	Spring item code	Spring colour	d	Lo	De	Min.	Max.
1	2701260	White	3.5	60	35	0.7	1.01
2	2701530	Yellow	4			1.011	1.96
3	2701790	Yellow/black	4.5			1.961	3.2
4	2702070	Orange	5			3.201	3.75
5	2702280	White/red	5.5			3.751	5

d = Wire Diameter (mm) **Lo** = Spring Length (mm) **De** = Outside Diameter (mm) **Min./Max.** = Pressure (bar)

Tab. 13.145.

Mod. SN-92 - Min pressure

Pos.	Spring item code	Spring colour	d	Lo	De	Min.	Max.
1	2700513	Red	2	40	15	0.25	0.4
2	2700713	Green	2.3			0.401	0.62
3	2700750	Black	2.5			0.621	1.55
4	2700985	Brown	3			1.551	3.01

d = Wire Diameter (mm) **Lo** = Spring Length (mm) **De** = Outside Diameter (mm) **Min./Max.** = Pressure (bar)

Tab. 13.146.

TM0020ENG

