

PVS 803

Pilot-Operated
Safety Relief Valves

Classification and area of application

The **PVS 803** is a servo actuated safety valve in which the opening and closing of the valve are controlled by a control device sensitive to pressure variations.

The **PVS 803** is a piloted safety valve to be used in all applications where rapid opening and reliable repositioning after closure are essential.

It is Truly a **TOP ENTRY** design, which confers to the regulator management advantages, for example the ability to perform full maintenance without uninstalling it from the connection pipe.

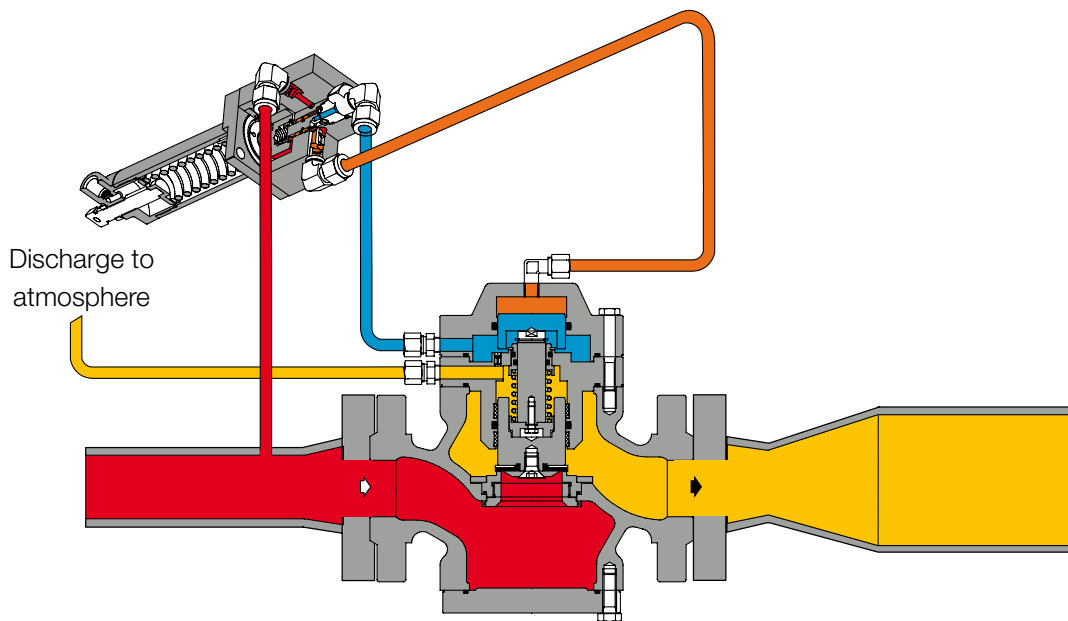



Fig.1 **PVS 803** - Pilot-operated safety relief valves

 Inlet pressure  Atmospheric pressure  Motorisation pressure  Control pressure

Features

Operating Features:*

- **Maximum inlet pressure:** 100 bar
- **Opening start pressure:** 10% max
- **Minimum environmental temperature:** Up to -20°C
- **Maximum environmental temperature:** Up to +60°C
- **Inlet gas temperature:** Up to -20°C +60°C

Construction Features:

- **DN Nominal dimensions:** 25 (1"); 50 (2"); 80 (3"); 100 (4"); 150 (6");
- **Flanged connections:** Class 150, 300, 600 according to EN1759-1 PN16, PN 50, PN 100 according to ISO 7005

Materials: **

- **Body:** Steel ASTM A216WCB / ASTM A352LCC
- **Valve seat:** Stainless steel
- **Plug:** Steel ASTM A350LF2
- **Sealing ring:** Nitrile rubber / Fluorocarbon
- **Connection fittings:** In zinc-plated carbon steel according to DIN 2353; Stainless steel on request

Pilots:

The **PVS 803** pilot-operated safety relief valves are, alternatively, equipped with the following pilots:

- **P16/M:** Action range 1.5-40 barg
- **P17/M:** Action range 40-74 barg

NOTE: * Different operating features available on request.
 ** The above materials refer to standard operations.
 Different materials can be provided for specific needs.

Sizing of the pilot-operated safety relief valves

In general, the sizing of the safety valve involves determining the pressure drop under given operating conditions through the valve itself, verifying that such pressure drop is compatible with the plant parameters specified in the request.

Sizing	
	
For the sizing of the involved valves, kindly refer to our website: www.fiorentini.com/sizing	
	Tab.1

Typical Connection Diagrams

The following examples are provided as a recommendation to get the best performances from the safety valve **PVS 803**.

IN-LINE INSTALLATION

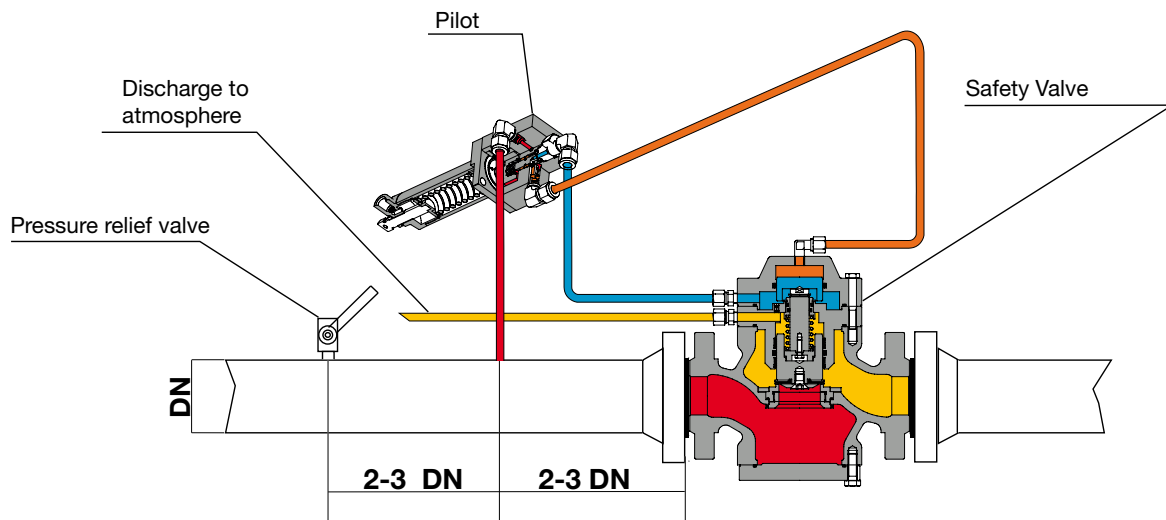

Fig.2

Recommended Installations

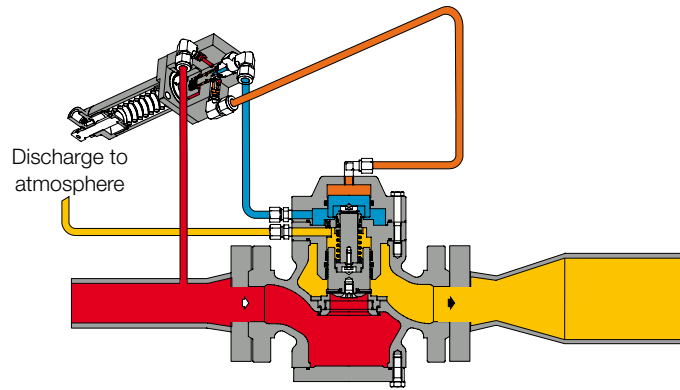

Fig.3 PVS 803 - Horizontal installation

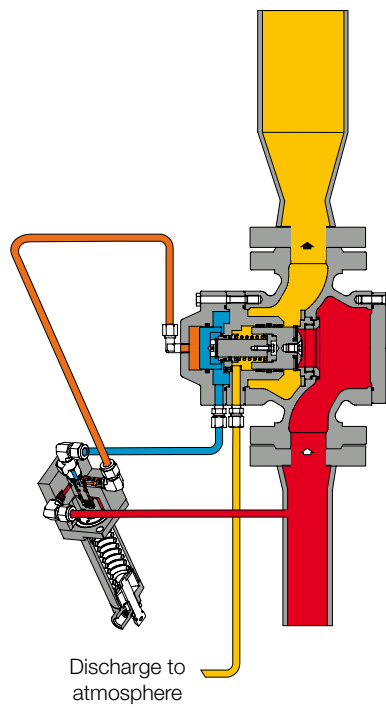

Fig.4 PVS 803 - Vertical installation

 Inlet pressure

 Atmospheric pressure

 Motorisation pressure

 Control pressure

Dimensions

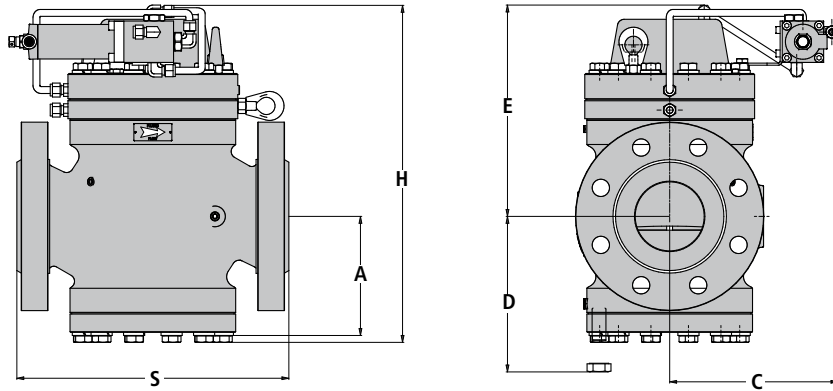

Fig.5

Diameter [mm]					
Millimetres	25	50	80	100	150
Inches	1"	2"	3"	4"	6"
S - Ansi 150/Pn16	183	254	298	352	451
S - Ansi 300	197.4	267	317	368	473
S - Ansi 600	210	286	336	394	508
A	78.5	108	132	168	222
C	195	211	229	250	286
D	115	158	194	225	309
E	250	265	295	300	456
H	335	385	440	481	695
					Tab.2

Dimension S according to EN 334 and IEC 534-3

Weights [kg]					
Ansi 150/Pn16	18	34	63	110	128
Ansi 300	19	36	67	115	138
Ansi 600	20	38	71	126	160
					Tab.3

www.fiorentini.com

The data are not binding. We reserve
the right to make changes without
prior notice.

