

Terval/A

Medium Low Pressure Gas Regulator



TECHNICAL BROCHURE

Pietro Fiorentini S.p.A.

Via E.Fermi, 8/10 | 36057 Arcugnano, Italy | +39 0444 968 511
sales@fiorentini.com

The data are not binding. We reserve the right
to make changes without prior notice.

tervala_technicalbrochure_ENG_revB

www.fiorentini.com

Who we are

We are a global organization specialized in designing and manufacturing technologically advanced solutions for natural gas treatment, transmission and distribution systems.

We are the ideal partner for operators in the Oil & Gas sector, with a business offer that goes across the whole natural gas chain.

We are in constant evolution to meet our customers' highest expectations in terms of quality and reliability.

Our aim is to be a step ahead of the competition, with customized technologies and an after-sale service program undertaken with the highest grade of professionalism.



Pietro Fiorentini advantages



Localised technical support



Experience since 1940



We operate in over 100 countries

Area of Application

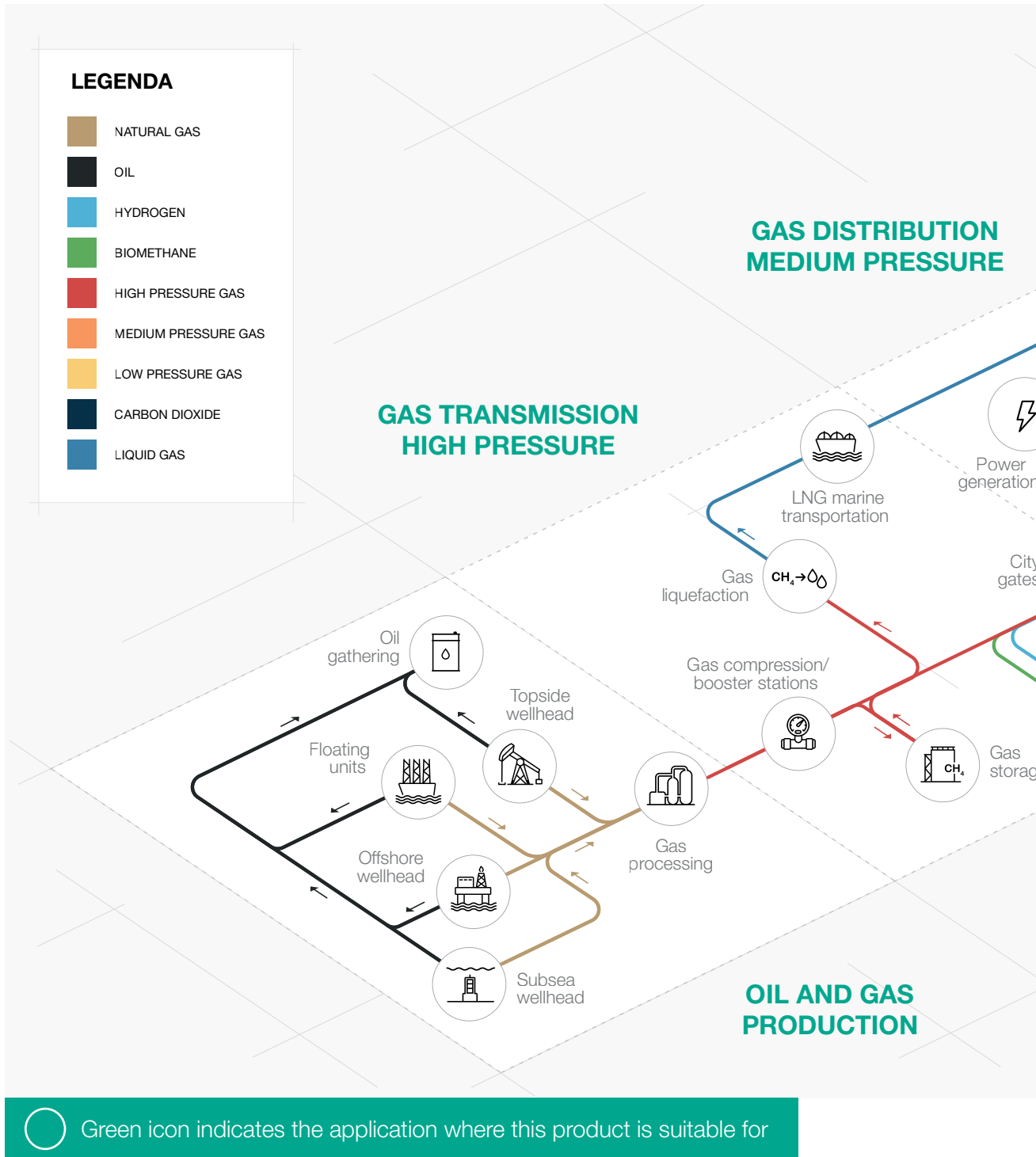

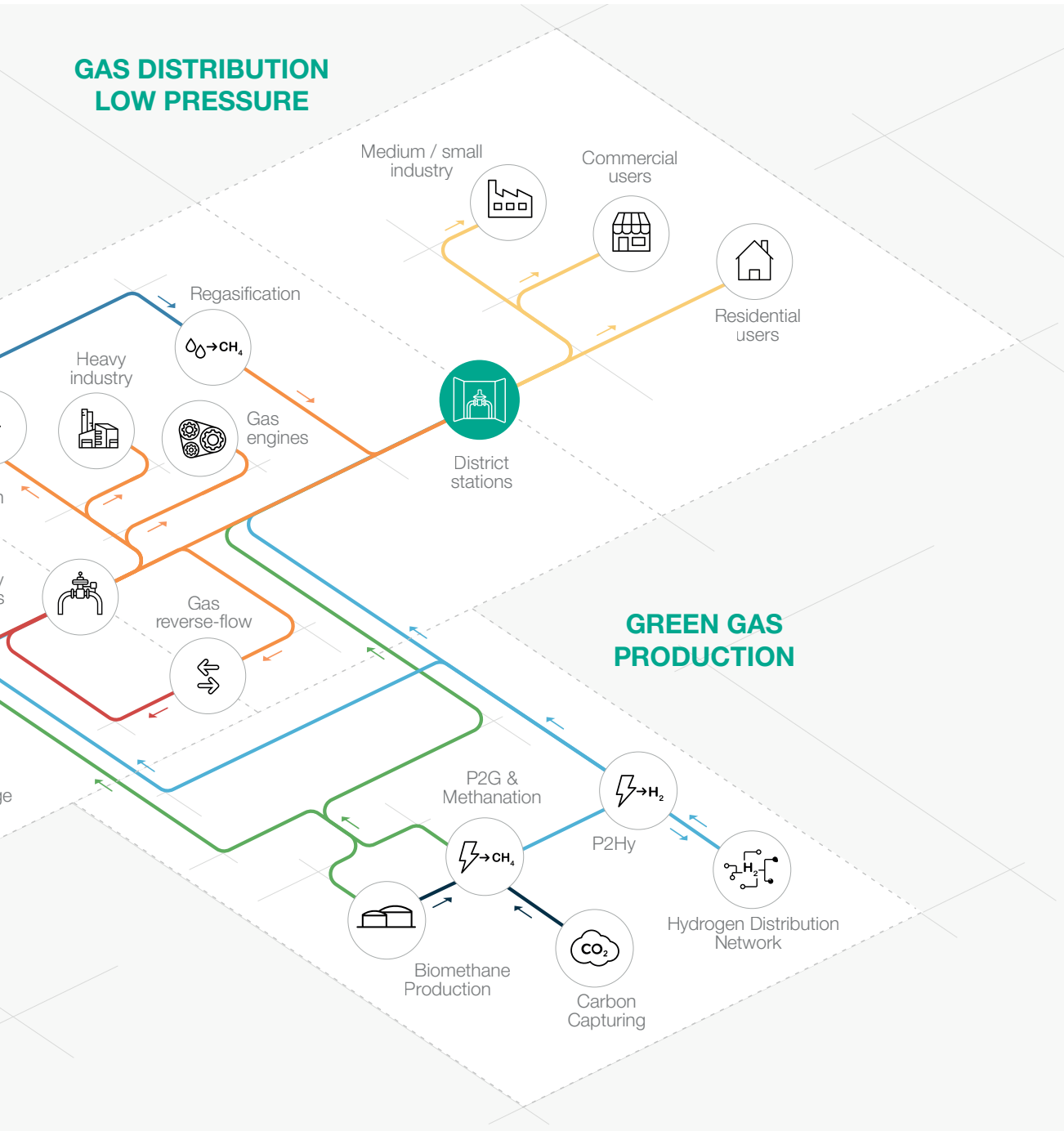

Figure 1 Area of Application Map



Introduction

Terval/A is one of the **pilot-operated gas pressure regulators** designed and manufactured by Pietro Fiorentini.

This device is suitable for use with previously filtered non-corrosive gases, and it is mainly used for medium and low pressure natural gas distribution networks.

According to the European Standard EN 334, it is classified as **Fail Open**.

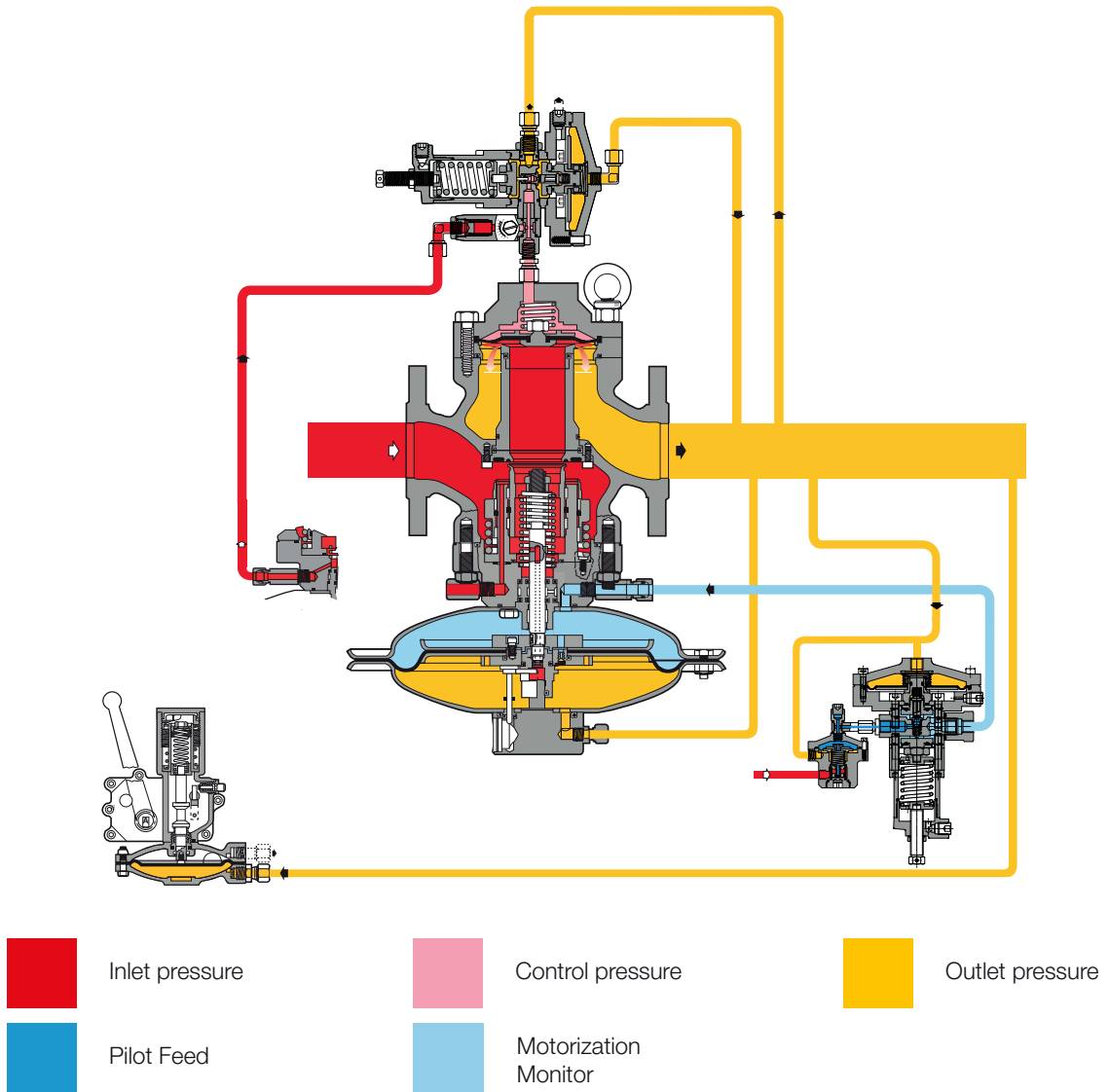

Figure 2 Terval/A

Features and Calibration ranges

Terval/A is a **pilot-operated** device for medium pressure and low pressure with a unique **dynamic balancing system** which ensures an **outstanding turn down ratio** combined with an extremely **accurate outlet pressure control**.

A balanced pressure regulator it is a pressure regulator where delivery pressure accuracy it is not affected by the fluctuation of the inlet pressure and flow during its operation. Therefore, a balance pressure regulator can have a single orifice for all pressure and flow operating conditions.

This regulator is suitable for use with previously filtered, non corrosive gases and distribution networks as well as high load industrial applications.

It is a **truly top entry design** which allows an **easy maintenance** of parts directly in the field **without removing the body from the pipework**.

Set point adjustment of the regulator is operated via a pilot unit used to load and unload the bleeding pressure from the top chamber.

The modular design of Terval/A pressure regulators allows to have both emergency monitor PM/182 and slam shut SA simultaneously on the same body.

Futhermore it can be equipped with silencer DB/93 model on the same body too.

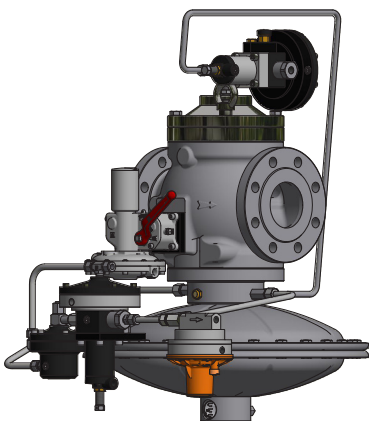

Figure 3 Terval/A

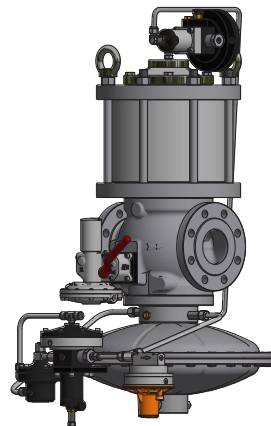

Figure 4 Terval/A with silencer DB



Terval/A competitive advantages



Balanced type



Top Entry



Operates with low differential pressure



Easy maintenance



High accuracy



Low noise



3 functions in 1 body



Built-in accessories



Built-in pilot filter



Biomethane compatible and 10% Hydrogen blending compatible. Higher blending available on request

Features

Features	Values
Design pressure*	up to 2.5 MPa up to 25 barg
Ambient temperature*	from -20 °C to +60 °C from -4 °F to +140 °F
Inlet gas temperature range*	from -20 °C to +60 °C from -4 °F to +140 °F
Inlet pressure range bpu (MAOP)	from 0.05 to 2.5 MPa from 0.5 to 25 barg
Range of downstream pressure Wd	from 0.0005 to 0.95 MPa from 0.005 to 9.5 barg
Available Accessories	DB Silencer
Minimum differential pressure	0.045 MPa 0.45 barg
Accuracy class AC	up to 5
Lock-up pressure class SG	up to 10
Nominal dimensions DN	DN 50 / 2" DN 65 / 2" 1/2; DN 80 / 3"; DN 100 / 4"
Connections*	Class 150 RF or RTJ according to ASME B 16.5 and PN 25 and 40 according to ISO 7005

(*) REMARK: Different functional features and/or extended temperature ranges available on request. Stated temperature ranges are the maximum for which the equipment's full performance, including accuracy, are fulfilled. Standard product may have a narrower range.

Table 1 Features

Materials and Approvals

Part	Material
Body	Cast steel ASTM A216 WCB for all sizes Ductile iron GS 400-18 ISO 1083 for all sizes
Cover	Rolled or forged carbon steel
Seat	Technopolymer
Diaphragm	Vulcanized rubber
Sealing ring	Nitrile rubber
Compression fittings	According to DIN 2353 in zinc-plated carbon steel. Stainless steel on request

REMARK: The materials indicated above refer to the standard models. Different materials can be provided according to specific needs.

Table 2 Materials

Construction Standards and Approvals

Terval/A regulator is designed according to the European standard EN 334.
The regulator reacts in opening (Fail Open) according to EN 334.

The product is certified according to European Directive 2014/68/EU (PED).
Leakage class: bubble tight, better than VIII according to ANSI/FCI 70-3.



EN 334



PED-CE



Pilot ranges and types

Type	Model	Operation	Range Wh		Spring Table web link
			KPa	mbarg	
Main pilot	301/.	Manual	0.5 - 10	5 - 100	TT 1037
Type	Model	Operation	Range Wh		Spring Table web link
			MPa	barg	
Main pilot	301/.TR	Manual	0.01 - 0.2	0.1 - 2	TT 1037
Main pilot	302/.	Manual	0.08 - 0.95	0.8 - 9.5	TT 653

Table 3 Settings Table

Pilot adjustment	
Pilot type .../A	Manual setting
Pilot type .../D	Electric remote setting control
Pilot type .../CS	Pneumatic remote setting control
Pilot type .../FIO	Smart unit for remote setting, monitoring, flow limitation

Table 4 Pilot adjustment table

General link to the calibration tables: [PRESS HERE](#) or use the QR code:



The pilot system comes complete with an adjustable AR100 restrictor. The flow rate of the pilot system is controlled by the bleed rate through the AR100 restrictor which influences the response time of the regulator.

Pressure drop through the adjustable AR100 restrictor shall be about 0.02 MPa (0.2 barg) at the minimum opening flow of the regulator and about 0.1 MPa (1 barg) at the maximum opening flow of the regulator.

Accessories

For the pressure regulators:

- Cg limiter
- Silencer

For the pilot circuit:

- Supplementary filter CF14 or CF14/D

Incorporated monitor and slam shut

The unique feature of Terval series pressure regulators is to have emergency monitor and slam shut device incorporated together with the active regulator in the same body.

This provides a three functions device in a single body allowing smaller footprint for the installation.



Monitor PM/182

This emergency regulator (monitor) is directly integrated onto the body of the main regulator. Both pressure regulators, therefore, use the same valve body, although they have independent actuators, pilots and valve seats.







The monitor is normally in fully open position during normal operation of the active regulator and takes over on in the event of its failure.

The operational characteristics of the PM/182 monitor are the same as for the Reval 182 regulator (refer to that specific catalogue).

The Cg coefficients of regulator having an incorporated monitor is 5% lower than those for standard version.

This solution allows the construction of reduction pressure lines with compact dimensions.

Another great advantage offered by the incorporated monitor regulator is that **it can be installed at any time**, even on an existing regulator, **without major changes to the pipework.**

-  Compact dimensions
-  Completely independent
-  "Fail to close" action
-  Built-in pilot filter
-  Visual opening indicator
-  Easy maintenance
-  Limit switch option
-  Accelerator option

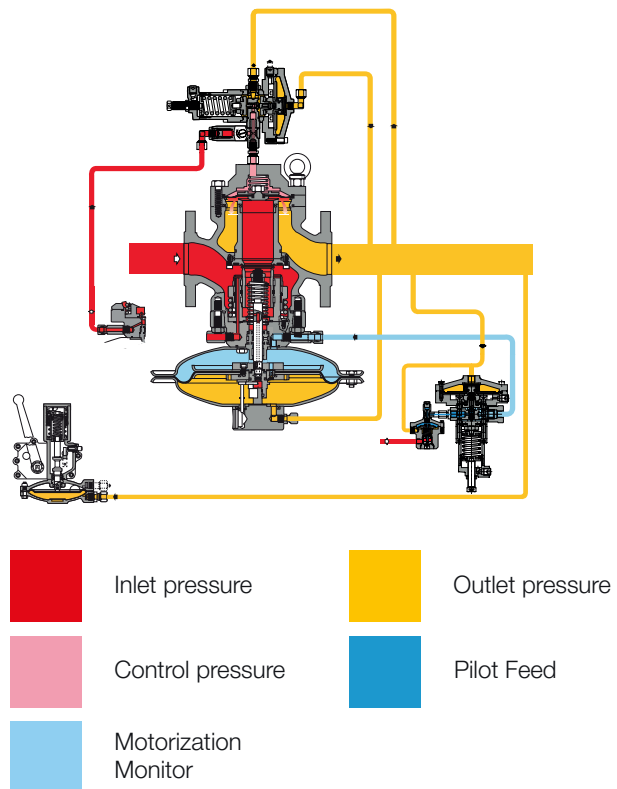

Figure 5 Terval/A PM/182

Type	Model	Operation	Range Wh		Spring Table web link
			MPa	barg	
Main pilot	204/A	Manual	0.03 - 4.3	0.3 - 43	TT 433
Main pilot	205/A	Manual	2 - 6	20 - 60	TT 799
Main pilot	206/A	Manual	3.2 - 6.5	32 - 65	TT 1050
Main pilot	207/A	Manual	4.1 - 7.4	41 - 74	TT 1146

Table 5 Setting table

Types of pilot adjustment	
Pilot type .../A	Manual setting
Pilot type .../D	Electric remote setting control
Pilot type .../CS	Pneumatic remote setting control
Pilot type .../FIO	Smart unit for remote setting, monitoring, flow limitation

Table 6 Pilot adjustment table

The monitor regulator can be equipped with an additional pilot called “accelerator” to enable a quick response time during the monitor take over. According to PED the accelerator is required on the monitor when acting as a safety accessory.

Type	Model	Operation	Range Wh		Spring Table web link
			MPa	barg	
Accelerator	V/25 BP	Manual	0.0015 – 0.02	0.015 – 0.2	TT 00601
Accelerator	V/25 MP	Manual	0.02 – 0.06	0.2 – 0.6	TT 00601
Accelerator	M/A	Manual	0.03 - 2	0.3 - 20	TT 354
Accelerator	M/A1	Manual	2 - 6.3	20 - 63	TT 892
Accelerator	M/A2	Manual	4 - 7.5	40 - 75	TT 892

Table 7 Accelerator adjustment table

General link to the calibration tables: [PRESS HERE](#) or use the QR code:





Silencer DB

Whenever certain noise limit is desired, an additional silencer allows to considerably reduce the noise level (dBA).

The Terval/A pressure regulator can be supplied with an **incorporated silencer**.

The high efficiency rely to the fact that noise absorption takes place at the same point where the noise is generated, thus preventing its propagation.

With the built-in silencer, the Cg valve coefficient is 5% lower than the corresponding version without.

Given the modular arrangement of the regulator, the silencer may be retrofitted **without the need to modify the main piping**.

Pressure reduction and control operate the same manner as standard version.

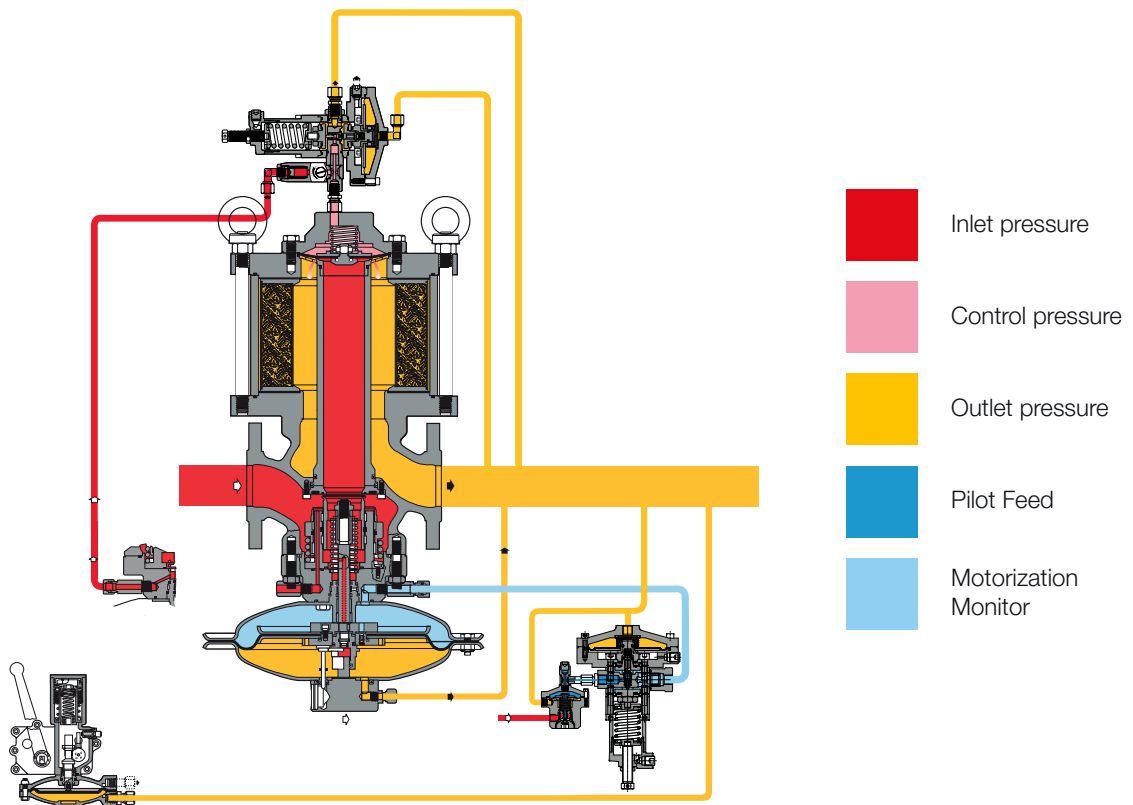

Figure 6 Terval/A with Silencer DB

Below charts represents the silencer effectiveness based on some common reference conditions for 2", 3" and 4". For actual calculations at specific desired conditions please refer to the online sizing tool or contact your closest Pietro Fiorentini representative.

- Pd 0.002 MPa | 0.02 barg NO Silencer
- Pd 0.002 MPa | 0.02 barg DB
- Pd 0.05 MPa | 0.5 barg NO SILENCER
- Pd 0.05 MPa | 0.5 barg DB
- Pd 0.2 MPa | 2 barg NO Silencer
- Pd 0.2 MPa | 2 barg DB
- Recommended noise limit (85 dBA at 1 mt | 3 feet)

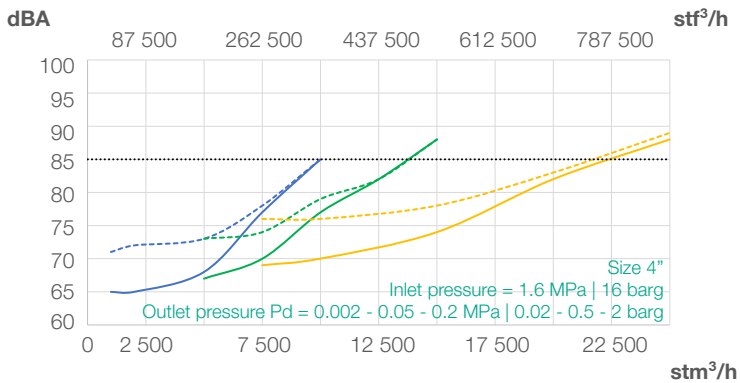
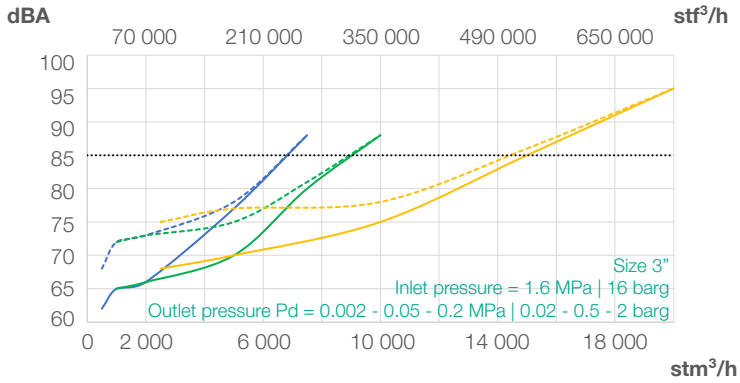
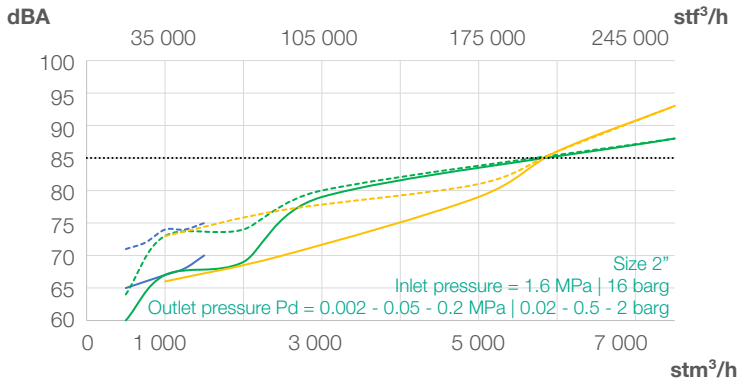
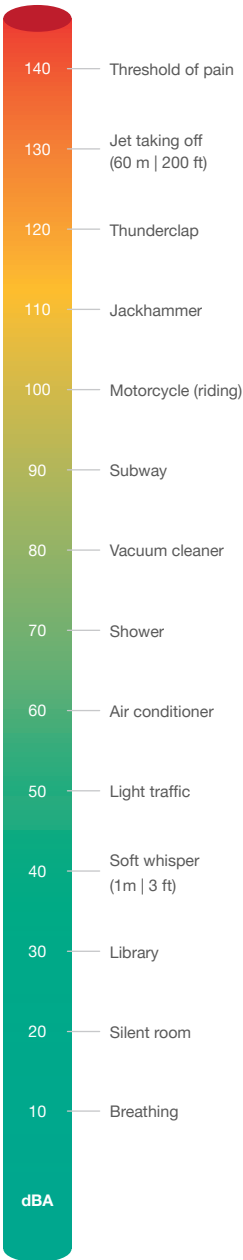

Chart 1 Terval/A's silencer efficiency charts



Slam shut SA









The Terval/A pressure regulator offers the possibility of installing an **incorporated slam shut valve SA** valve and this can be done either during the manufacturing process or be retrofitted in the field.

SA is available for all sizes.

Retrofitting can be done without modifying the pressure regulator assembly.

With the built-in slam shut, the Cg valve coefficients is 5% lower than the corresponding version without.

The main characteristics of this device are:

-  Over Pressure Shut-Off
-  Under Pressure Shut-Off
-  Internal by-pass
-  Push button for tripping test
-  Compact dimensions
-  Easy maintenance
-  Remote tripping option
-  Limit switch option

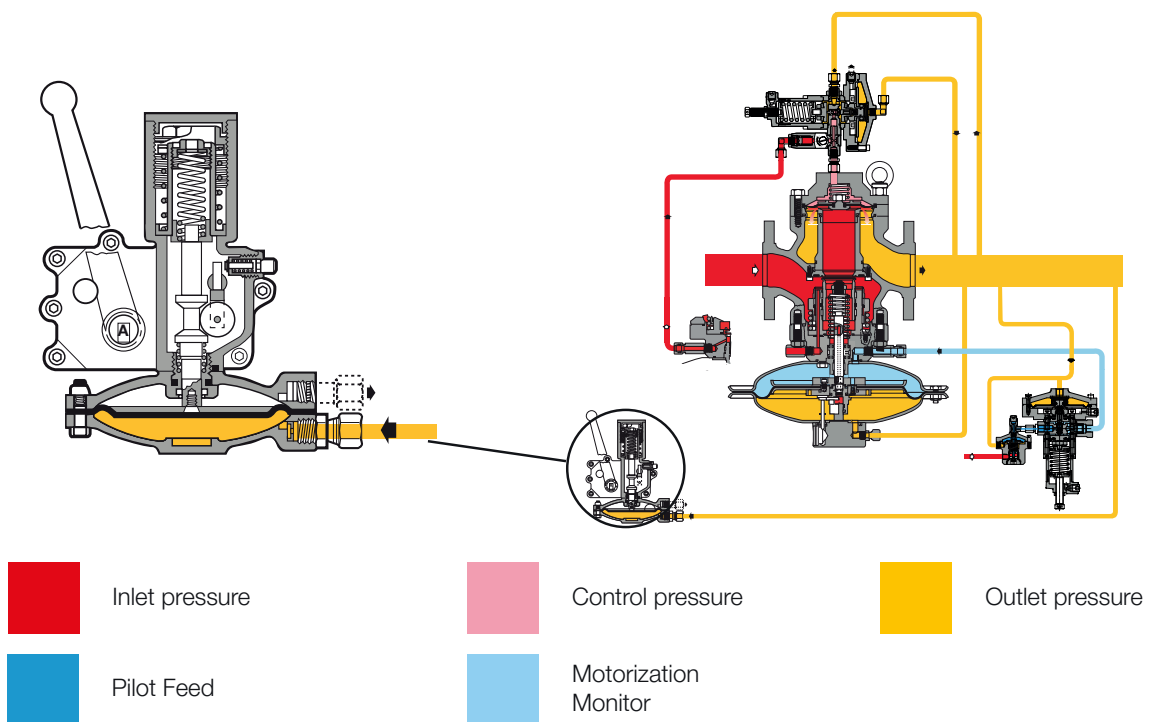

Figure 7 Terval/A SA

Pressure switch types and ranges					
SSV Type	Model	Operation	Range Wh		Spring Table web link
			KPa	mbarg	
SA	91	OPSO	2.5 - 110	25 - 1100	TT 1381
		UPSO	1 - 90	10 - 900	
SSV Type	Model	Operation	Range Wh		Spring Table web link
			MPa	barg	
SA	92	OPSO	0.07 - 0.5	0.7 - 5	TT 1381
		UPSO	0.025 - 0.301	0.25 - 3.01	
SA	93	OPSO	0.3 - 1.33	3 - 13.3	TT 1381
		UPSO	0.08 - 0.77	0.8 - 7.7	

Table 8 Setting table



Weights and Dimensions

Terval/A

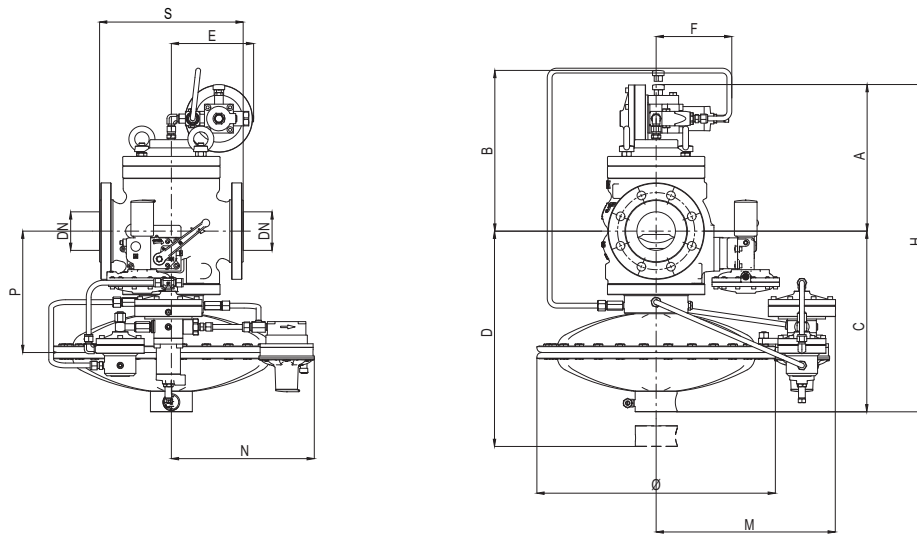

Figure 8 Terval/A dimensions

Weights and Dimensions (for other connections please contact your closest Pietro Fiorentini representative)				
	[mm] inches	[mm] inches	[mm] inches	[mm] inches
Size (DN)	50 2"	65 2" 1/2	80 3"	100 4"
S - ANSI 150/PN16	254 10"	276 10.87"	298 11.73"	352 13.86"
Ø	375 14.76"	495 19.49"	495 19.49"	495 19.49"
A	313 12.32"	341 13.42"	346 13.62"	429 16.89"
B	323 12.72"	351 13.82"	356 14.01"	439 17.28"
C	308 12.13"	373 14.68"	380 14.96"	410 16.14"
D	430 16.93"	530 20.87"	530 20.87"	600 23.62"
E	178 7.01"	178 7.01"	178 7.01"	178 7.01"
F	160 6.30"	160 6.30"	160 6.30"	160 6.30"
H	613 24.13"	715 28.15"	725 28.54"	843 33.19"
M	320 12.60"	385 15.16"	385 15.16"	385 15.16"
N	290 11.42"	298 11.73"	303 11.93"	306 12.05"
P	205 8.07"	250 9.84"	260 10.24"	290 11.42"
Tubing connections	Øe 10 x Øi 8 (on request imperial sizing)			
Weight	Kg lbs	Kg lbs	Kg lbs	Kg lbs
ANSI 150/PN 16	60 132	94 207	110 242	140 309"

Table 9 Weights and dimensions

Terval/A + DB/93

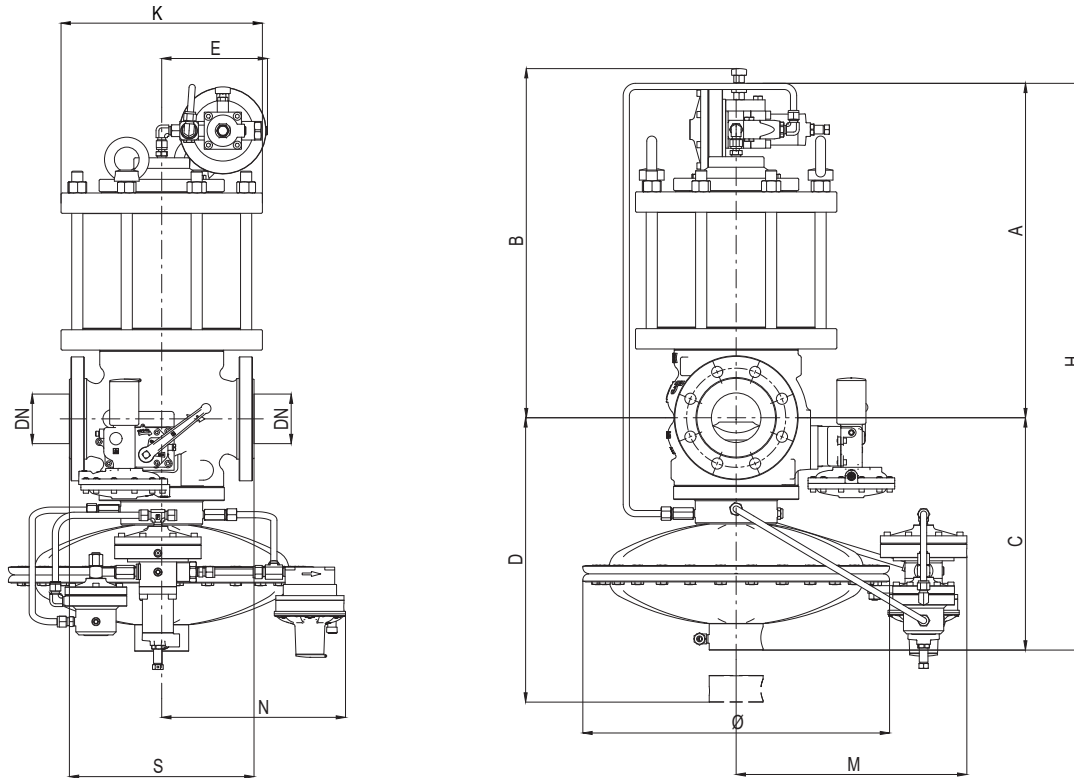

Figure 9 Terval/A + DB/93 dimensions

Weights and Dimensions (for other connections please contact your closest Pietro Fiorentini representative)				
	[mm] inches	[mm] inches	[mm] inches	[mm] inches
Size (DN)	50 2"	65 2" 1/2	80 3"	100 4"
S - ANSI 150/PN16	254 10"	276	298 11.73"	352 13.86"
Ø	375 14.76"	495 19.49"	495 19.49"	495 19.49"
A	487 19.17"	555 21.85"	576 22.68"	678 26.69"
B	497 19.57"	565 22.24"	586 23.07"	688 27.09"
C	308 12.13"	373 14.68"	380 14.96"	410 16.14"
D	430 16.93"	530 20.87"	530 20.87"	600 23.62"
E	178 7.01"	178 7.01"	178 7.01"	178 7.01"
H	795 31.30"	913 35.95"	980 38.58"	1088 42.83"
M	320 12.60"	385 15.16"	385 15.16"	385 15.16"
N	290 11.42"	298 11.73"	303 11.93"	306 12.05"
K	295 11.61"	325 12.80"	330 12.99"	390 15.35"
Tubing connections	Øe 10 x Øi 8 (on request imperial sizing)			
Weight	Kg lbs	Kg lbs	Kg lbs	Kg lbs
ANSI 150/PN 16	94 207	124 273	152 335	210 463

Table 10 Weights and dimensions



Sizing and Cg

In general, the choice of a regulator is made based on the calculation of the flow rate determined by the use of formulae using the flow rate coefficients (Cg) and the form factor (K1) as indicated by the EN 334 standard.

Flow rate coefficient				
Nominal size	50	65	80	100
Inches	2"	2" 1/2	3"	4"
Cg	1706	2731	3906	5490
K1	108	104	100	100

Table 11 Flow rate coefficient

For sizing [PRESS HERE](#) or use the QR code:



Note: In case you do not have the proper credentials to access, feel free to contact your closest Pietro Fiorentini representative.

In general the online sizing considers multiple variables as the regulator is installed in a system, enabling a better and multiperspective approach to the sizing.

For different gases, and for natural gas with a different relative density other than 0.61 (compared to air), the correction coefficients from the following formula shall be applied.

$$F_c = \sqrt{\frac{175,8}{S \times (273,16 + T)}}$$

S = relative density (refere to table 12)
T = gas temperature (°C)

Correction Factor Fc		
Gas Type	Relative Density S	Correction Factor Fc
Air	1.00	0.78
Propane	1.53	0.63
Butane	2.00	0.55
Nitrogen	0.97	0.79
Oxygen	1.14	0.73
Carbon Dioxide	1.52	0.63

Note: the table shows the Fc correction factors valid for Gas, calculated at a temperature of 15°C and at the declared relative density.

Table 12 Correction factor Fc

Flow rate conversion
$\text{Stm}^3/\text{h} \times 0.94795 = \text{Nm}^3/\text{h}$

Nm^3/h reference conditions T= 0 °C; P= 1 barg
 Stm^3/h reference conditions T= 15 °C; P= 1 barg

Table 13 Flow rate conversion

CAUTION:

In order to get optimal performance, to avoid premature erosion phenomena and to limit noise emissions, it is recommended to check that the gas speed at the outlet flange does not exceed the values of the graph below. The gas speed at the outlet flange may be calculated by means of the following formula:

$$V = 345.92 \times \frac{Q}{\text{DN}^2} \times \frac{1 - 0.002 \times \text{Pd}}{1 + \text{Pd}}$$

V = gas speed in m/s
 Q = gas flow rate in Stm^3/h
 DN = nominal size of regular in mm
 Pd = outlet pressure in barg

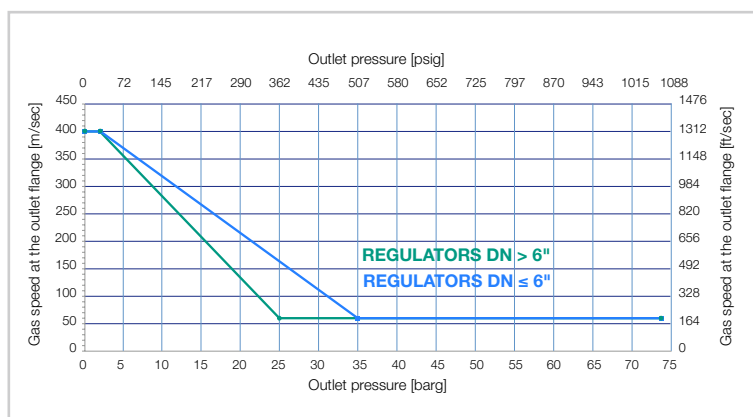



Sizing of regulators is usually made based on valve Cg value (table 11).

Flow rates at fully open position and various operating conditions are related by the following formulae where:

Q = flow rate in Stm³/h

Pu = inlet pressure in bar (abs)

Pd = outlet pressure in bar (abs).

- **A** > when the Cg value of the regulator is known, as well as Pu and Pd, the flow rate can be calculated as follows:

- **A-1** in sub critical conditions: (Pu < 2 x Pd)

$$Q = 0.526 \times C_g \times P_u \times \sin \left(K_1 \times \sqrt{\frac{P_u - P_d}{P_u}} \right)$$

- **A-2** in critical conditions: (Pu ≥ 2 x Pd)

$$Q = 0.526 \times C_g \times P_u$$

- **B** > vice versa, when the values of Pu, Pd and Q are known, the Cg value, and hence the regulator size, may be calculated using:

- **B-1** in sub-critical conditions: (Pu < 2 x Pd)

$$C_g = \frac{Q}{0.526 \times P_u \times \sin \left(K_1 \times \sqrt{\frac{P_u - P_d}{P_u}} \right)}$$

- **B-2** in critical conditions (Pu ≥ 2 x Pd)

$$C_g = \frac{Q}{0.526 \times P_u}$$

NOTE: The sin value is understood to be DEG.



**Pietro
Fiorentini**



Pietro Fiorentini

TB0017ENG



The data are not binding. We reserve the right
to make changes without prior notice.

tervala_technicalbrochure_ENG_revB

www.fiorentini.com